



Switching and Control



Switching and Control

	Technical Information	134
Series 3700A	System Switch/Multimeter and Plug-In Cards . . .	136
Selector Guide	Plug-In Cards and Accessories for Series 3700A . .	146
	Plug-In Cards for Series 3700A	148–169
7001	80-channel Switch/Control Mainframe	172
7002	400-channel Switch/Control Mainframe	174
Selector Guide	Switch Cards for 7001, 7002	176–177
Selector Guide	Switch Card Accessories for 7001, 7002	177
	Switch Cards for 7001, 7002	178–193
707B	Six-slot Semiconductor Switching Matrix Mainframe	194
708B	Single-slot Semiconductor Switching Matrix Mainframe	194
Selector Guide	Switch Cards and Accessories for 707B, 708B . . .	200
	Switch Cards for 707B, 708B	201–207
System 41	RF/Microwave Signal Routing Systems	208
System 46	32-channel, Unterminated, RF/Microwave Switch System	210
System 46T	32-channel, Terminated, RF/Microwave Switch System	213
7116-MWS	Pre-Configured 1×16, Unterminated, RF/Microwave Switch System	215

Technical Information

Switching and Control

Achieving required system accuracies and precision requires selection of appropriate instruments, creativity in designing test methods, and careful attention to specifications and error terms. Most test system designs are complex enough that it is in the designer's best interest to minimize the number of uncontrolled variables. To accomplish this, the system switch performance should be tightly specified.

Special consideration should be given to tests that approach the specified limits of accuracy, resolution, or sensitivity of the measurement or sourcing instruments. These generally represent the "most critical test requirements," and switching should be selected to support these tests. A system designed to perform against the "most critical test requirements" will usually satisfy other test requirements as well.

How Do I Specify a Switch System for My Application?

Whether you are designing your own switching system or preparing to contact Keithley's applications department for assistance, you need to define certain parameters for your test system and understand how you want everything interconnected.

First, define your parameters. This includes:

- Measurements—List all the required measurement types and accuracies.
- Sources—List all the sources required.
- Quantity—List the number of terminals on the DUT and how many devices are involved.
- Signal characteristics—List signal types, levels and frequency, and impedance requirements.
- Speed—What are the speed requirements?

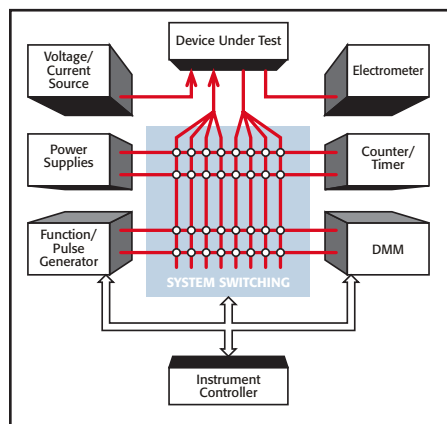

Figure 1. General Purpose Test System

- Environment—Temperature, humidity, etc.
- Communication interface—GPIB, RS-232, Ethernet, USB

Next, sketch the system. Given the number of terminals on the device and the number of instruments (source and measure), develop a picture of what type of switch and configuration will be needed. This is likely to be an iterative process as you identify what types of switching equipment are actually available.

Once you have done the groundwork, you are ready to configure the switching for your test system:

- Determine the appropriate switch and switch card configurations
- Select the appropriate switch system
- Select source and measure equipment
- Select cables and/or other accessories
- Identify need for fuses, limit resistors, diodes, etc.
- Determine the uncertainties and compare them with the required accuracies

Switching Configurations

The variety and size of switching configurations available determine the efficiency of the final switching design, including the amount and complexity of cabling and interconnect at the time of system integration. These are the basic building blocks of any switching system.

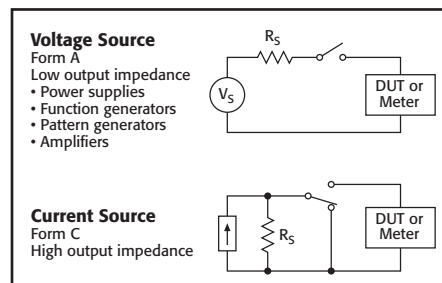

Figure 2. Example Switching Configurations

A switching configuration can be described by the electrical property being switched, its mechanical construction, or its function in the test system (Figure 2). These descriptions of the signal paths or electrical interconnects are necessary for laying out and wiring the test system.

A matrix switch (Figure 3) is the most versatile type of system switching. But first, a word on terminology here — Do not confuse a switch matrix

(often called a switching mainframe) with a matrix switch. With a matrix switch, any input can be connected to any output, singly or in combination. This helps minimize the need for complex wiring and interconnect systems and can simplify the DUT interface. Although a matrix switch will work in virtually any switching application, it should not necessarily be your first choice of switch configuration.

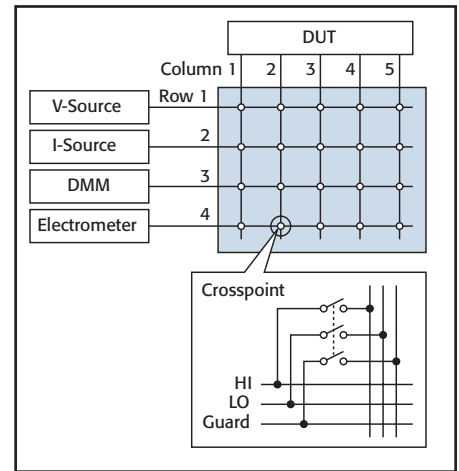

Figure 3. Matrix Switch

Consider an example where you need to connect four different instruments to ten different test points on a device-under-test. If you need to be able to connect any combination of instruments to any combination of test points at any time, then you do need a matrix switch. But, if you only need to connect one instrument to one test point at any time, then you can combine a four-to-one multiplexer with a one-to-ten multiplexer to make your connections. The multiplexer approach only uses 14 relays, while the full matrix uses 40. If you simply choose a matrix switch for the second example, you will end up paying for 26 relay channels you don't need. Careful planning can result in a more compact and economical switch system.

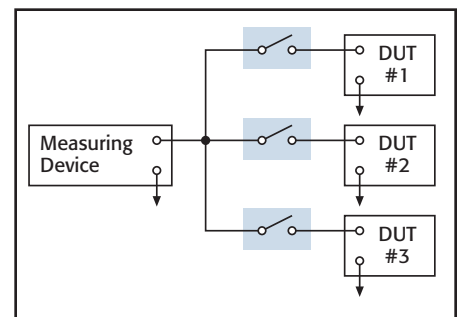

Figure 4. Multiplex Switch

Technical Information

Switching and Control

A multiplex switch (Figure 4) connects one instrument to multiple devices under test or multiple instruments to one device under test. The multiplex switch is useful in combination with matrix or other configurations to expand switching capacity by sharing electrical paths, to provide additional isolation and reduce crosstalk between channels, or to build special configurations.

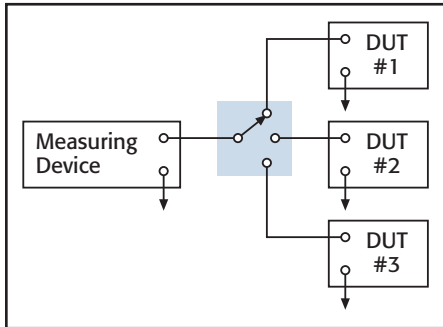

Figure 5. Scanner Switch

A scanner (Figure 5) is a special case of multiplex switching in which switch closures are sequential or serial, sometimes with the capability to skip channels.

The isolated switch configuration consists of individual uncommitted relays, often with multiple poles. Isolated switches are not connected to any other circuit, and are therefore free for building very flexible and unique combinations of input/output configurations with the addition of some external wiring. This type of switch can be useful for creating additional isolation between circuits, providing safety interlock, actuating other relays or circuits, or building special topologies such as binary ladders and tree structures.

Electrical Specifications

Electrical specifications of the switching cards contribute significantly to the overall performance and signal integrity in the test system. When trying to achieve high accuracy, resolution, and sensitivity or to route high frequency signals, high currents, and high voltages with minimum degradation in the test signal, the electrical performance of the switch card must be known. Match the system's critical test requirements against the specified performance of the switch. If the requirement is to measure a one-volt reference to one microvolt, be certain that the contact potential of the switch is not hundreds of microvolts. If switching of power supply voltage is required, be certain that the switch has sufficient current carrying capacity. When measuring resistances of less than one k Ω , be certain the switch will support four-wire measurements.

CHARACTERISTICS	NECESSARY FOR:
Contact potential (limits low voltage signal switching)	Precision measurement of voltage signals of less than 1V, as in reference testing, drift testing, and temperature coefficient testing.
Current offset (limits low current signal switching)	Measurement of signals of less than 1mA, as in semiconductor characterization and insulation resistance tests.
Characteristic impedance	Signal integrity in RF switching.
Thermocouple cold junction reference	Accurate measurements of thermocouple sensor devices.
Four-wire (automatic pairing of channels to facilitate switching of source and sense leads)	Precision measurement of resistance less than 1k Ω and switching of remote sensing voltage supplies.
Maximum current	Switching of power supplies and high power circuits.
Maximum voltage	Isolation and safety in high voltage systems.
Maximum power	Determining maximum current and/or maximum voltage that a relay can switch to prevent damaging the printed circuit board and relays.
Switch life	Determining maximum switch activations that can be expected under hot or cold switching.

Figure 6. Switching Performance Characteristics

The switching card specifications represent the performance of a single card. If additional cards are connected together, actual performance parameters such as offset current and insertion loss will be a function of the entire system, not just a single card. Each extra card and connecting cable adds some degradation. It may be necessary to characterize the entire system (including switching) in some applications.

Figure 6 describes a few performance characteristics and where they apply to improve system performance. There are many other characteristics to consider, depending on the type and level of signal being switched and the expected performance from the test system. The switching selector guides group switching cards according to key performance features. Many switches actually fit into multiple categories and you should look carefully at all of the switch card specifications before making a final selection. Refer to Keithley's Switching Handbook for a more in-depth discussion of switching specifications and their effect on measurement performance.

Mainframe Capabilities

A switching mainframe provides a convenient mechanical and programming environment for Keithley switching cards and can be selected to suit the size of the system. The Model 3706A offers six slots in a full rack 2U high enclosure and is compatible with a growing family of high density and high speed switching cards. For more diverse signal ranges the Models 7001 (two-slot) and 7002 (ten-slot) switch systems are compatible with the full range of more than 30 cards.

For low level semiconductor applications, the Model 707B (six slots) and 708B (one slot) main-

frames are compatible with six specialized high density configurations including high speed, low leakage matrix configurations.

Switching Density

The high channel capacity Keithley mainframes provide reduces the complexity of a switch application by minimizing the number of mainframes and cards required. The Model 3706A is our highest density switching mainframe offering up to 576 two-wire multiplexer channels in a single 2U high, full rack mainframe. The half-rack 7001 has a capacity of up to 80 two-pole channels, and the ten-slot 7002 can accommodate 400 two-pole channels. The 707B can handle up to 576 channels or matrix crosspoints, while the 708B can accommodate up to 96 channels or crosspoints. The high density cards for each of these mainframes are designed for easy interconnect and wiring.

Channel Status

The Series 3700A with its LXI class B compliance offers an elaborate embedded web browser interface for intuitive point and click control and monitoring of all switch positions. The Series 7000 and 700 switch mainframes provide a visual display of each switch position on the front panel.

Expansion

The mainframe Models 3706A, 7001, 7002, and 707B each provide an analog backplane that can be used to make connections between cards when building large matrix or multiplexer configurations that require several cards. The backplane eliminates intercard wiring and increases configuration flexibility.

Series 3700A

System Switch/Multimeter and Plug-In Cards



- Six-slot system switch mainframe with optional high performance multimeter
- Multi-processor architecture optimized for high throughput scanning and pattern switching applications
- Remote PC control via Ethernet, USB, and GPIB interfaces
- Up to 576 two-wire or 720 one-wire multiplexer channels in one mainframe
- Up to 2,688 one-pole matrix crosspoints in one mainframe
- Embedded Test Script Processor (TSP®) offering unparalleled system automation, throughput, and flexibility
- TSP-Link® master/slave connection provides easy system expansion and seamless connection to Series 2600 and 2600A SourceMeter® instruments
- Capable of over 14,000 readings per second to memory with optional high performance multimeter
- LXI Class B Version 2 with embedded Web browser interface for test setup, maintenance, and basic application control

The Series 3700A offers scalable, instrument grade switching and multi-channel measurement solutions that are optimized for automated testing of electronic products and components. The Series 3700A includes four versions of the Model 3706A system switch mainframe along with a growing family of plug-in switch and control cards. When the Model 3706A mainframe is ordered with the high performance multimeter, you receive a tightly integrated switch and measurement system that can meet the demanding application requirements in a functional test system or provide the flexibility needed in stand-alone data acquisition and measurement applications.

Maximizes System Control and Flexibility

To provide users with greater versatility when designing test systems, the Series 3700A mainframes are equipped with many standard features. For example, easy connectivity is supported with three remote interfaces: LXI/Ethernet, General Purpose Interface Bus (GPIB), and Universal Serial Bus (USB). Fourteen digital I/O lines are also included, which are programmable

and can be used to control external devices such as component handlers or other instruments. Additionally, system control can be greatly enhanced by using our Test Script Processor (TSP) technology. This technology provides “smart” instruments with the ability to perform distributed processing and control at the instrument level versus a central PC.

High Quality Switching at a Value Price

The Series 3700A builds upon Keithley's tradition of producing innovative, high quality, precise signal switching. This series offers a growing family of high density and general purpose plug-in cards that accommodates a broad range of signals at very competitive pricing. The Series 3700A supports applications as diverse as design validation, accelerated stress testing, data acquisition, and functional testing.

Model 3706A Mainframe

The Series 3700A includes the base Model 3706A system switch/multimeter mainframe with three options for added flexibility. This mainframe contains six slots for plug-in cards in a compact 2U high (3.5 inches/89mm) enclosure that easily accommodates the needs of medium to high channel count applications. When fully loaded, a mainframe can support up to 576 two-wire multiplexer channels or 2,688 one-pole matrix crosspoints for unrivaled density and economical per channel costs.

High Performance, 7½-digit Multimeter (DMM)

The high performance multimeter option provides up to 7½-digit measurements, offering 26-bit resolution to support your ever-increasing test accuracy requirements. This flexible resolution supplies a DC reading rate from >14,000 readings/second at 3½ digits to 60 readings/second at 7½ digits to accommodate a greater span of applications.

The multimeter does not use a card slot, so you maintain all six slots in your mainframe. In addition, the multimeter is wired to the mainframe's analog backplane, ensuring a high quality signal path from each card channel to the multimeter.

The multimeter supports 13 built-in measurement functions, including: DCV, ACV, DCI, ACI, frequency, period, two-wire ohms, four-wire ohms, three-wire RTD temperature, four-wire RTD temperature, thermocouple temperature, thermistor temperature, and continuity. In addition, the multimeter offers extended low ohms (1Ω) and low current (10μA) ranges. In-rack calibration is supported, which reduces both maintenance and calibration time.

Single Channel Reading Rates

NPLC	DCV/ 2 Wire Ohms		4 Wire Ohms
	DCV/ 2 Wire Ohms	4 Wire Ohms	
1.0	60	29	
0.2	295	120	
0.06	935	285	
0.006	6,200	580	
0.0005	14,100	650	

1.888.KEITHLEY (U.S. only)
www.keithley.com

KEITHLEY

A GREATER MEASURE OF CONFIDENCE

Series 3700A

System Switch/Multimeter and Plug-In Cards

Ordering Information

Mainframes

3706A Six-slot system switch with high performance DMM

3706A-NFP

Six-slot system switch with high performance DMM, without front panel display and keypad

3706A-S Six-slot system switch

3706A-SNFP

Six-slot system switch, without front panel display and keypad

Plug-in Cards

3720 Dual 1×30 multiplexer card (auto CJC when used with 3720-ST)

3721 Dual 1×20 multiplexer card (auto CJC when used with 3721-ST)

3722 Dual 1×48, high density, multiplexer card

3723 Dual 1×30, high speed, reed relay multiplexer card

3724 Dual 1×30 FET multiplexer card

3730 6×16, high density, matrix card

3731 6×16 high speed, reed relay matrix card

3732 Quad 4×28, ultra-high density, reed relay matrix card

3740 32 channel isolated switch card

3750 Multifunction control card

Accessories Supplied

Test Script Builder Software Suite CD

Ethernet Crossover Cable (CA-180-3A)

Series 3700A Product CD (includes LabVIEW®, IVI C, and IVI.COM drivers)

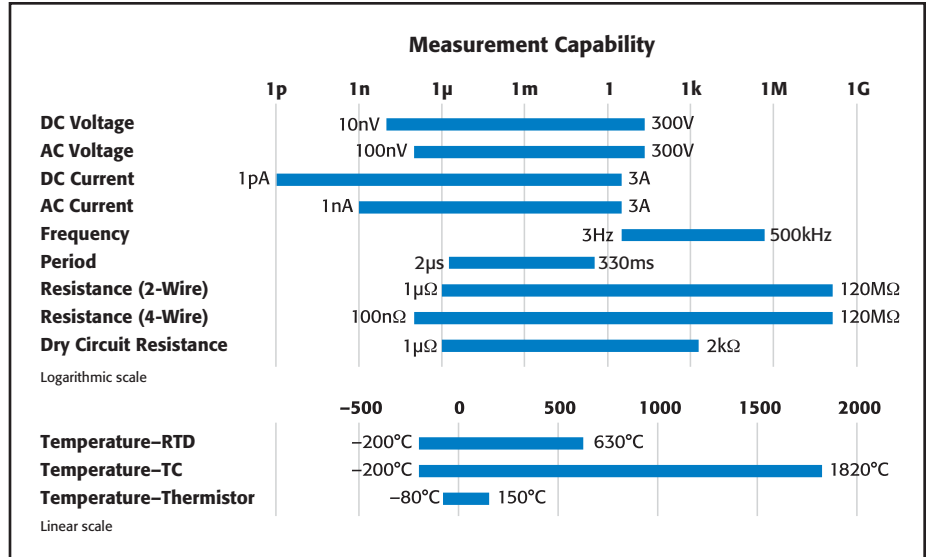

Measurement capabilities of the high performance multimeter

ACCESSORIES AVAILABLE

GPIB INTERFACES AND CABLES

7007-1	Shielded GPIB Cable, 1m (3.5ft)
7007-2	Shielded GPIB Cable, 2m (6.6ft)
KPCI-488LPA	IEEE-488 Interface/Controller for the PCI Bus
KUSB-488B	IEEE-488 USB-to-GPIB Interface Adapter

DIGITAL I/O, TRIGGER LINK, AND TSP-LINK

2600-TLINK	Trigger I/O to Trigger Link Interface Cable, 1m (3.3 ft)
CA-126-1	Digital I/O and Trigger Cable, 1.5m (4.9 ft)
CA-180-3A	CAT5 Crossover Cable for TSP-Link

MULTIMETER CONNECTORS

3706-BAN	DMM Adapter Cable, 15-pin D-sub to banana jacks, 1.4m (4.6 ft)
3706-BKPL	Analog Backplane Extender Board, 15-pin D-sub to terminal block
3706-TLK	Test Lead Kit, includes 3706-BAN and plug-in test lead accessories
8620	Shorting Plug

RACK MOUNT KIT

4288-10	Fixed Rear Rack Mount Kit
---------	---------------------------

SERVICES AVAILABLE

Mainframe Models 3706A and 3706A-NFP

3706A-3Y-EW	1 Year Factory Warranty Extended to 3 Years
3706A-5Y-EW	1 Year Factory Warranty Extended to 5 Years
C/3706A-3Y-STD	Calibration Contract, 3 Years, Standard Calibration*
C/3706A-3Y-DATA	Calibration Contract, 3 Years, Z540 Compliant Calibration with Data*
C/3706A-3Y-ISO	Calibration Contract, 3 Years, ISO 17025 Accredited Calibration*
C/3706A-5Y-STD	Calibration Contract, 5 Years, Standard Calibration*
C/3706A-5Y-DATA	Calibration Contract, 5 Years, Z540 Compliant Calibration with Data*
C/3706A-5Y-ISO	Calibration Contract, 5 Years, ISO 17025 Accredited Calibration*

Mainframe Models 3706A-S and 3706A-SNFP

3706A-S-3Y-EW	1 Year Factory Warranty Extended to 3 Years
3706A-S-5Y-EW	1 Year Factory Warranty Extended to 5 Years

SOFTWARE SERVICES

SYSTEM DEVELOPMENT OR IMPLEMENTATION

Other service contracts are available; please contact us for details.

*Not available in all countries.

1.888.KEITHLEY (U.S. only)

www.keithley.com

KEITHLEY

A GREATER MEASURE OF CONFIDENCE

Series 3700A

System Switch/Multimeter and Plug-In Cards

TSP Distributed Control Increases Test Speed and Lowers Test Cost

TSP technology enhances instrument control by allowing users the choice of using standard PC control or of creating embedded test scripts that are executed on microprocessors within the instrument. By using TSP test scripts instead of a PC for instrument control, you avoid communication delays between the PC controller and instrument, which results in improved test throughput. Test scripts can contain math and decision-making rules that further reduce the interaction between a host PC and the instrument.

This form of distributed control supports the autonomous operation of individual instruments or groups of instruments and can possibly remove the need for a high level PC controller, which lowers test and ownership costs. This is the same proven TSP technology found in our innovative Series 2600A System SourceMeter instruments.

TSP-Link Technology for Easy and Seamless System Coordination and Expansion

If your channel density requirements grow or if you need to process more signal types, use TSP-Link technology to expand your system. The TSP-Link master/slave connection offers easy system expansion between Series 3700A mainframes. You can also use TSP-Link technology to connect to other TSP-Link enabled instruments such as Series 2600A SourceMeter instruments. Everything connected with TSP-Link can be controlled by the master unit, just as if they were all housed in the same chassis.

This high speed system expansion interface lets users avoid the complex and time consuming task of expanding their remote interfaces to another mainframe. There is no need to add external triggers and remote communication cables to individual instruments, since all TSP-Link connected devices can be controlled from a single master unit.

Test Script Builder Software Suite

Test Script Builder is a software tool that is provided with all Series 3700A instruments to help users easily create, modify, debug, and store TSP test scripts. It supplies a project/file manager window to store and organize test scripts, a text-sensitive program editor to create and modify test TSP code, and an immediate instrument control window to send Ethernet, GPIB, and USB commands and to receive data from the instrument. The immediate window also allows users to see the output of a given test script and simplifies debugging.

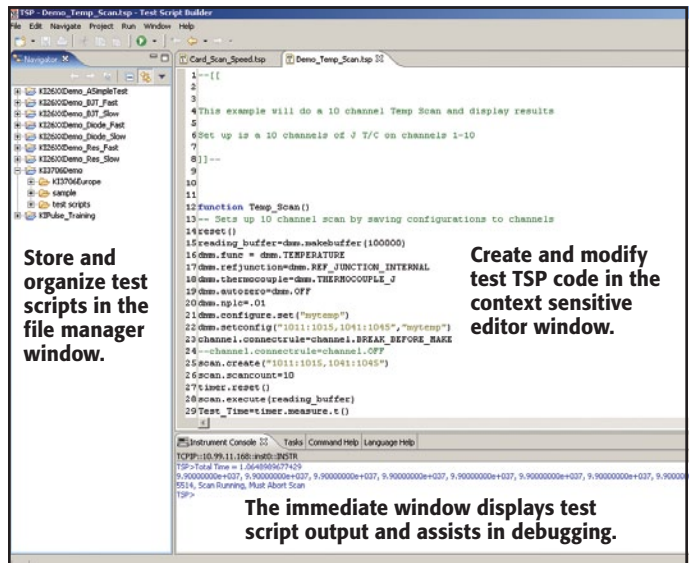

Store and organize test scripts in the file manager window.

Create and modify test TSP code in the context sensitive editor window.

The immediate window displays test script output and assists in debugging.

Test Script Builder Software Suite

LXI Class B Version 2

Series 3700A mainframes are LXI Class B Version 2 compliant instruments. The features include a 10/100M Base-T Ethernet connection, graphical Web server, LAN based instrument triggering, and IEEE 1588 precision time protocol (PTP) synchronization. PTP time synchronization provides a standard method to synchronize devices on an Ethernet network with microsecond precision for time/event based programming.

Transportable Memory, USB 2.0 Device Port

All Model 3706A mainframes contain a USB device port for easy transfer of readings, configurations, and test scripts to memory sticks. This port, which is located on the front panel, provides you with easy access to and portability of measurement results. Simply plug in a memory stick and, with a few simple keystrokes, gain access to virtually unlimited memory storage. Additional capabilities include: saving and recalling system configurations and storage for TSP scripts.

Series 3700A

System Switch/Multimeter and Plug-In Cards

Embedded Web Server

The built-in Web interface offers a quick and easy method to control and analyze measurement results. Interactive schematics of each card in the mainframe support point-and-click control for opening and closing switches. A scan list builder is provided to guide users through the requirements of a scan list (such as trigger and looping definitions) for more advanced applications. When the mainframe is ordered with the multimeter, additional Web pages are included for measurement configuration and viewing, including a graphing toolkit.

Built-in Web Server Interface

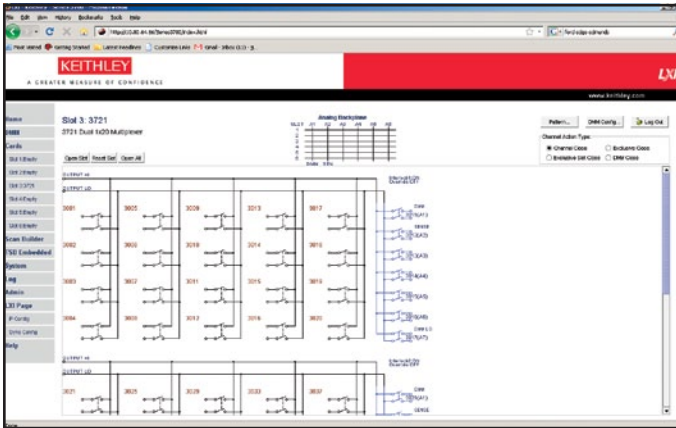

1. Configure your switch channels and measurement functions. Configure the DMM to make your measurements at the desired speed, resolution, etc. and assign them to the desired channels.



2. Build and run your automated scan list. The toolkit makes it easy to build and execute an automated sequence of channel-open and channel-close commands and triggered multimeter measurements.



3. Analyze your data. View your results in real-time or historical mode with point-and-click simplicity. Data can be exported directly to your PC in either numerical or graphical formats for presentation or other applications.



Model 3706A front panel



Model 3706A-S front panel



Model 3706A-NFP and Model 3706A-SNFP front panel



Model 3706A rear panel

System switch with high performance multimeter

SWITCHING AND CONTROL

1.888.KEITHLEY (U.S. only)
www.keithley.com

KEITHLEY

A GREATER MEASURE OF CONFIDENCE

Series 3700A

System Switch/Multimeter and Plug-In Cards

High Performance Multimeter Specifications (Rev. A)

DC Specifications

CONDITIONS: 1 PLC or 5 PLC.

For <1PLC, add appropriate "ppm of range" adder from "RMS Noise" table.

Includes rear panel Analog Backplane connector and transducer conversion. Refer to DC Notes for additional card uncertainties.

Function	Range ¹	Resolution	Test Current or Burden Voltage	Input Resistance or Open Circuit Voltage ²	Accuracy: ±(ppm of reading + ppm of range) (ppm = parts per million) (e.g., 10ppm = 0.001%)			Temperature Coefficient 0°–18°C and 28°–50°C
					24 Hour ³ 23°C ± 1°C	90 Day 23°C ± 5°C	1 Year 23°C ± 5°C	
Voltage ⁴	100.00000 mV ¹⁹	0.01 μV		>10 GΩ or 10 MΩ ±1%	10 + 9	25 + 9	30 + 9	(1 + 5)°C
	1.0000000 V ¹⁹	0.1 μV		>10 GΩ or 10 MΩ ±1%	7 + 2	25 + 2	30 + 2	(1 + 1)°C
	10.000000 V	1 μV		>10 GΩ or 10 MΩ ±1%	7 + 2	20 + 2	25 + 2	(1 + 1)°C
	100.00000 V	10 μV		10 MΩ ±1%	15 + 6	35 + 6	40 + 6	(5 + 1)°C
	300.00000 V	100 μV		10 MΩ ±1%	20 + 6	35 + 6	40 + 6	(5 + 1)°C
Resistance ^{4, 5, 6, 7}	1.0000000 Ω	0.1 μΩ	10 mA	8.2 V	15 + 80	40 + 80	60 + 80	(8 + 1)°C
	10.000000 Ω	1 μΩ	10 mA	8.2 V	15 + 9	40 + 9	60 + 9	(8 + 1)°C
	100.00000 Ω	10 μΩ	1 mA	13.9 V	15 + 9	45 + 9	65 + 9	(8 + 1)°C
	1.0000000 kΩ	100 μΩ	1 mA	13.9 V	20 + 4	45 + 4	65 + 4	(8 + 1)°C
	10.000000 kΩ	1 mΩ	100 μA	9.1 V	15 + 4	40 + 4	60 + 4	(8 + 1)°C
	100.00000 kΩ	10 mΩ	10 μA	14.7 V	20 + 4	45 + 5	65 + 5	(8 + 1)°C
	1.0000000 MΩ	100 mΩ	10 μA	14.7 V	25 + 4	50 + 5	70 + 5	(8 + 1)°C
	10.000000 MΩ	1 Ω	0.64 μA/10 MΩ	6.4 V	150 + 6	200 + 10	400 + 10	(70 + 1)°C
	100.00000 MΩ	10 Ω	0.64 μA/10 MΩ	6.4 V	800 + 30	2000 + 30	2000 + 30	(385 + 1)°C
	1.0000000 Ω	1 μΩ	10 mA	27 mV	25 + 80	50 + 80	70 + 80	(8 + 1)°C
Dry Circuit Resistance ^{6, 8}	10.000000 Ω	10 μΩ	1 mA	20 mV	25 + 80	50 + 80	70 + 80	(8 + 1)°C
	100.00000 Ω	100 μΩ	100 μA	20 mV	25 + 80	90 + 80	140 + 80	(8 + 1)°C
	1.0000000 kΩ	1 mΩ	10 μA	20 mV	25 + 80	180 + 80	400 + 80	(8 + 1)°C
	2.0000000 kΩ	10 mΩ	5 μA	20 mV	25 + 80	320 + 80	800 + 80	(8 + 1)°C
	Continuity (2W)	1.000 kΩ	100 mΩ	1 mA	13.9 V	40 + 100	100 + 100	100 + 100
Current ⁹	10.000000 μA	1 pA	<61 mV		40 + 50	300 + 50	500 + 50	(35 + 9)°C
	100.00000 μA	10 pA	<105 mV		50 + 9	300 + 30	500 + 30	(50 + 5)°C
	1.0000000 mA	100 pA	<130 mV		50 + 9	300 + 30	500 + 30	(50 + 5)°C
	10.000000 mA	1 nA	<150 mV		50 + 9	300 + 30	500 + 30	(50 + 5)°C
	100.00000 mA	10 nA	<0.4 V		50 + 9	300 + 30	500 + 30	(50 + 5)°C
	1.0000000 A	100 nA	<0.6 V		200 + 60	500 + 60	800 + 60	(50 + 10)°C
	3.0000000 A	1 μA	<1.8 V		1000 + 75	1200 + 75	1200 + 75	(50 + 10)°C

TEMPERATURE

(Displayed in °C, °F, or K. Exclusive of probes errors.)

THERMOCOUPLES (Accuracy based on ITS-90):

Type	Range	Resolution	90 Day/1 Year, 23°C ± 5°C Simulated reference junction	90 Day/1 Year, 23°C ± 5°C Using 3720, 3721, or 3724 Cards	Range	90 Day/1 Year, 23°C ± 5°C Using 3720, 3721, or 3724 Cards	Temperature Coefficient 0°–18°C and 28°–50°C
J	–150 to + 760°C	0.001°C	0.2°C	1.0°C	–200 to –150°C	1.5°C	0.03°C/°C
K	–150 to +1372°C	0.001°C	0.2°C	1.0°C	–200 to –150°C	1.5°C	0.03°C/°C
N	–100 to +1300°C	0.001°C	0.2°C	1.0°C	–200 to –100°C	1.5°C	0.03°C/°C
T	–100 to +400°C	0.001°C	0.2°C	1.0°C	–200 to –100°C	1.5°C	0.03°C/°C
E	–150 to +1000°C	0.001°C	0.2°C	1.0°C	–200 to –150°C	1.5°C	0.03°C/°C
R	+400 to +1768°C	0.1°C	0.6°C	1.8°C	0 to +400°C	2.3°C	0.03°C/°C
S	+400 to +1768°C	0.1°C	0.6°C	1.8°C	0 to +400°C	2.3°C	0.03°C/°C
B	+1100 to +1820°C	0.1°C	0.6°C	1.8°C	+350 to +1100°C	2.8°C	0.03°C/°C

4-WIRE RTD OR 3-WIRE RTD (100Ω platinum [PT100], D100, F100, PT385, PT3916, or user 0Ω to 10kΩ) (Selectable Offset compensation On or Off):

For 3-wire RTD, dmm.connect=dmm.CONNECT_FOUR_WIRE, ≤0.1Ω lead resistance mismatching in Input HI and LO. Add 0.25°C/0.15Ω of lead resistance mismatch.

4-Wire RTD	–200 to +630°C	0.01°C	0.06°C		0.003°C/°C
3-Wire RTD	–200 to +630°C	0.01°C	0.75°C		0.003°C/°C

THERMISTOR: 2.2kΩ, 5kΩ, and 10kΩ. Not recommended with Model 3724 card. See Model 3724 manual for "Measurement Considerations."

	–80 to +150°C	0.01°C	0.08°C		0.002°C/°C
--	---------------	--------	--------	--	------------

1.888.KEITHLEY (U.S. only)

www.keithley.com

KEITHLEY

A GREATER MEASURE OF CONFIDENCE

Series 3700A

System Switch/Multimeter and Plug-In Cards

SYSTEM PERFORMANCE 13, 14

3½-Digit Mode, Azero off, nPLC = 0.0005. Time includes function change from either DCV or 2WΩ to listed function.

Function	Function Change (ms)	Range Change (ms)	Auto-range (ms)
DCV or 2WΩ (<10kΩ)	10	10	10
4WΩ (<10kΩ)	20	20	20
DCI	10	10	10
Frequency or Period 17	110	10	—
ACV or ACI 17	20	85	300

Buffer Transfer Speed	Ethernet	GPIO	USB
Average for 1000 readings	2450/s	2000/s	1800/s
Average for 1000 readings with timestamp	2300/s	1800/s	1600/s

Card	Command	Single Command Execution Time (ms)		
		Ethernet	GPIO	USB
3720, 3721, 3722, 3730	channel.close (ch_list) or channel.open (ch_list)	5.7	5.8	6.1
3723, 3724 3731, 3732 18	channel.close (ch_list) or channel.open (ch_list)	2.3	2.4	2.7
3740	channel.close (ch_list 1-28) or channel.open (ch_list 1-28)	10.7	10.8	11.1
	channel.close (ch_list 29-32) or channel.open (ch_list 29-32)	22.7	22.8	23.1

DC MEASUREMENT CHARACTERISTICS

DC VOLTS

A-D LINEARITY: 1.0ppm of reading + 2.0 ppm of range.

INPUT IMPEDANCE: 100mV–10V Ranges: Selectable >10GΩ // <400pF or 10MΩ ±1%.
100V–300V Ranges: 10MΩ ±1%.

INPUT BIAS CURRENT: <50pA at 23°C with dmm.autozero=dmm.OFF or dmm.inputdivider=dmm.ON.

COMMON MODE CURRENT: <500nA p-p for ≤1MHz.

AUTOZERO OFF ERROR: For DCV ±1°C and ≤10 minutes, add ±(8ppm of reading + 5μV).

INPUT PROTECTION: 300V all ranges.

COMMON MODE VOLTAGE: 300V DC or 300Vrms (425V peak for AC waveforms) between any terminal and chassis.

RESISTANCE

MAX. 4WΩ LEAD RESISTANCE: 5Ω per lead for 1Ω range; 10% of range per lead for 10Ω–1kΩ ranges; 1kΩ per lead for all other ranges.

MAX. 4WΩ LEAD RESISTANCE (DRY CKT): 0.5Ω per lead for 1Ω range; 10% of range per lead for 10Ω–100Ω ranges; 50Ω per lead for 1kΩ–2kΩ ranges.

INPUT IMPEDANCE: 1Ω–10Ω Ranges: 99kΩ ±1% // <1μF.
100Ω–2kΩ Ranges: 10MΩ ±1% // <0.015μF.

OFFSET COMPENSATION: Selectable on 4WΩ 1Ω–10kΩ ranges.

OPEN LEAD DETECTOR: Selectable per channel. 1.5μA, ±20% sink current per DMM SHI and SLO lead. Default on.

CONTINUITY THRESHOLD: Adjustable 1 to 1000Ω.

AUTOZERO OFF ERROR: For 2WΩ ±1°C and ≤10 minutes, add ±(8ppm of reading + 0.5mΩ) for 10Ω and 5mΩ for all other ranges.

INPUT PROTECTION: 300V all ranges.

DC MEASUREMENT CHARACTERISTICS (continued)

DC CURRENT

AUTOZERO OFF ERROR: For ±1°C and ≤10 minutes, add ±(8ppm of reading + range error). Refer to table below.

Range	3 A	1 A	100 mA	10 mA	1 mA	100 μA	10 μA
Shunt Resistance guaranteed by design	0.05 Ω	0.05 Ω	1 Ω	10 Ω	100 Ω	1 kΩ	6 kΩ
Burden Voltage	<1.75 V	<0.55 V	<0.4 V	<150 mV	<130 mV	<105 mV	<61 mV
Burden Voltage with 3721 card	<2.35 V	<1.15 V	<0.4 V	<150 mV	<130 mV	<105 mV	<61 mV
Autozero OFF "of range" Error	100 μA	100 μA	5 μA	0.5 μA	50 nA	5 nA	0.85 nA

For each additional amp after ±1.5A input, add the following to ppm of range:

—	120	60	60	60	60	95
---	-----	----	----	----	----	----

INPUT PROTECTION: 3A, 250V fuse.

THERMOCOUPLES

CONVERSION: ITS-90.

REFERENCE JUNCTION: Internal, External, or Simulated (Fixed).

OPEN LEAD DETECTOR: Selectable per channel. Open >1.15kΩ ±50Ω. Default on.

COMMON MODE ISOLATION: 300V DC or 300Vrms (425V peak for AC waveforms), >10GΩ and <350pF any terminal to chassis.

DC NOTES

- 20% overrange on DC functions except 1% on 300V range and 3.33% on 3A range.
- ±5% (measured with 10MΩ input resistance DMM, >10GΩ DMM on 10MΩ and 100MΩ ranges). Refer to table for other 2W/4W configurations. For Dry Circuit, +20%, <1mV with dmm.offsetcompensation=ON for 100Ω–2kΩ ranges.

Range	2W	4W	4W–Kelvin	Ocomp 4W	Ocomp 4W–Kelvin
1, 10Ω	8.2 V	8.2 V	8.2 V	12.1 V	12.1 V
100, 1kΩ	13.9 V	14.1 V	13.9 V	15.0 V	12.7 V
10kΩ	9.1 V	9.1 V	9.1 V	0.0 V	0.0 V
100k, 1MΩ	12.7 V	14.7 V	12.7 V	—	—
10M, 100MΩ	6.4 V	6.4 V	6.4 V	—	—

- Relative to calibration accuracy.
- Add the following additional uncertainty with -ST accessory:

Card	±(ppm of range)			±(ppm of reading + ppm of range)			
	100mV	1V	10V	100kΩ	1MΩ	10MΩ	100MΩ
3720, 3721, 3722, and 3730	45	4.5	—	8 + 5	8 + 0.5	—	—
3723	60	6.0	—	8 + 6	8 + 0.5	—	—
3724	45	4.5	—	8 + 5	80 + 0.5	250 + 1	5000 + 1
3731	800	80	8	8 + 80	40 + 8	0 + 25	0 + 15
3732 (Quad 4×28)	200	20	2	8 + 20	40 + 2	0 + 7	0 + 4

- Specifications are for 4-wire Ω, 1Ω–1kΩ with offset compensation on. For Series 3700A plug-in cards, I_{sync} and offset compensation on. 1Ω range is 4-wire only. Model 3724 card: 1kΩ–100MΩ ranges only. Model 3731 card: 100Ω–100MΩ ranges only.

For 2-wire Ω specifications, add the following to "ppm of range" uncertainty:

DMM Connect Relays	Rel Enable	Rear Panel Connector		
		or 3700 Card	3724 Card	3731 Card
CONNECT_ALL	ON	100 mΩ	500 mΩ	900 mΩ
CONNECT_ALL	OFF	1.5 Ω	64 Ω	2.3 Ω
CONNECT_TWO_WIRE	ON	700 mΩ	1.2 Ω	1.5 Ω
CONNECT_TWO_WIRE	OFF	1.5 Ω	64 Ω	2.3 Ω

- Test current with dmm.offsetcompensation=OFF, ±5%.
- Add the following to "ppm of reading" uncertainty when using Series 3700A Plug-in Cards in Operating Environment ≥50%RH.

Card	10kΩ	100kΩ	1MΩ	10MΩ	100MΩ
3720, 3721, 3724, 3730, 3731, 3732 (Quad 4×28) with MTC D-Shell connector	1 ppm	10 ppm	0.01%	0.1%	1%
3720, 3721, 3724, 3730, 3731, 3732 (Quad 4×28) with -ST screw terminal module	10 ppm	100 ppm	0.1%	1%	10%
3722 and 3723	10 ppm	100 ppm	0.1%	1%	10%

Series 3700A Plug-in Cards Operating Environment: Specified for 0° to 50°C, ≤70%RH at 35°C.

- Dry-Ckt Ω is 4-wire only. Specifications with offset compensation and I_{sync} on.

Card	Ranges
3720, 3721, and 3730	1 Ω – 2 kΩ
3722, 3723, and 3732	10 Ω – 2 kΩ
3724	1 kΩ – 2 kΩ
3731	100 Ω – 2 kΩ

1.888.KEITHLEY (U.S. only)

www.keithley.com

KEITHLEY

Series 3700A

System Switch/Multimeter and Plug-In Cards

DC NOTES (continued)

9. Includes Analog Backplane 15-pin rear panel connector. For 3721, refer to DC Current table for additional uncertainties.

10. For I_{SYNC} On, line frequency $\pm 0.1\%$.

	nPLC	5	1	<0.2	<0.01
I_{SYNC} On	NMRR	110 dB	90 dB	45 dB	—
I_{SYNC} Off	NMRR	60 dB, ± 2 dB	60 dB, ± 2 dB	—	—

11. For 1k Ω unbalance in LO lead. AC CMRR is 70dB.

	nPLC	5	1	0.2 ¹²	≤ 0.2
CMRR		140 dB	140 dB	120 dB	80 dB

12. For I_{SYNC} On.

13. Reading rates are for 60Hz (50Hz) operation using factory defaults operating conditions dmm.reset("all"), Autorange off, dmm.autodelay=dmm.OFF, dmm.opendetector=dmm.OFF, format.data=format.SREAL. Ranges as follows: DCV = 10V, 2W Ω /4W Ω = 1k Ω , DCI = 1mA, Dry-Ckt Ω = 10 Ω , ACI = 1mA, and ACV = 1V. For

Dry-Ckt Ω with Offset Comp OFF 2k Ω , 60 rdg/s max. Dry-Ckt Ω with Offset Comp ON 2k Ω , 29.5 rdg/s max. For temperature reading rates use DCV for T/C and 2W Ω for Thermistor. Speeds are typical and include measurements and data transfer out the Ethernet, GPIB, or USB.

14. DMM configured for single reading, dmm.measurecount=1, and print(dmm.measure()). May require additional settling delays for full accuracy, depending on measurement configuration.

15. DMM configured for multisample readings and single buffer transfer, dmm.measurecount=1000, buf=dmm.makebuffer(1000), dmm.measure(buf), and printbuffer(1,1000,buf).

16. dmm.autozero=dmm.ON. RMS noise using low thermal short for DCV, 2W Ω , 4W Ω , and Dry-Ckt Ω . For DCI, dmm.connect=dmm.CONNECT_NONE or 0. For RTD, noise using low thermal 190 Ω precision resistor. Includes Model 3721 card accuracies. RMS noise values are typical.

17. For DCV or 2W Ω to Frequency or Period, dmm.nplc=0.2 and dmm.aperture=0.01 sec. For ACI or ACV, dmm.detectorbandwidth=300. For ACI or ACV with dmm.autodelay=dmm.ON, best speed is 65ms.

18. Speeds are within same multiplexer bank. Add an additional 8ms when changing banks or slots.

19. When properly zeroed using REL function.

AC Specifications

			Accuracy: \pm (% of reading + % of range) 23°C \pm 5°C						
Function	Range ¹	Resolution	Calibration Cycle	3 Hz–5 Hz	5 Hz–10 Hz	10 Hz –20 kHz	20 kHz–50 kHz	50 kHz–100 kHz	100 kHz–300 kHz
Voltage ²	100.0000 mV	0.1 μ V	90 Day (100mV–100V)	1.0 + 0.03	0.30 + 0.03	0.05 + 0.03	0.11 + 0.05	0.6 + 0.08	4.0 + 0.5
	1.000000 V	1 μ V		1.0 + 0.03	0.30 + 0.03	0.06 + 0.03	0.12 + 0.05	0.6 + 0.08	4.0 + 0.5
	10.00000 V	10 μ V	1 Year (100mV–100V)	1.0 + 0.03	0.30 + 0.03	0.06 + 0.03	0.12 + 0.05	0.6 + 0.08	4.0 + 0.5
	100.0000 V	100 μ V		1.0 + 0.05	0.30 + 0.05	0.05 + 0.05	0.11 + 0.08	0.6 + 0.11	4.0 + 0.8
	300.0000 V	1 mV	90 Day	1.0 + 0.05	0.30 + 0.05	0.05 + 0.05	0.11 + 0.08	0.6 + 0.11	4.0 + 0.8
	300.0000 V	1 mV		1 Year	1.0 + 0.05	0.30 + 0.05	0.06 + 0.05	0.12 + 0.08	0.6 + 0.11
Temp. Coeff. /°C ³ (all ranges)				0.010 + 0.003	0.030 + 0.003	0.005 + 0.003	0.006 + 0.005	0.01 + 0.006	0.03 + 0.01
			Accuracy: \pm (ppm of reading + offset ppm)						
Current ²	1.000000 mA ⁷	1 nA	90 Day/1 Year	1.0 + 0.04	0.30 + 0.04	0.08 + 0.03	0.09 + 0.03	0.09 + 0.03	
	10.00000 mA	10 nA		1.0 + 0.04	0.30 + 0.04	0.08 + 0.03	0.09 + 0.03	0.09 + 0.03	
	100.0000 mA	100 nA		1.0 + 0.04	0.30 + 0.04	0.08 + 0.03	0.09 + 0.03	0.09 + 0.03	
	1.000000 A	1 μ A		1.0 + 0.04	0.30 + 0.04	0.20 + 0.04	0.88 + 0.04	2.0 + 0.04	
	3.000000 A	10 μ A		1.0 + 0.05	0.30 + 0.05	0.20 + 0.05	0.88 + 0.05	2.0 + 0.05	
	Temp. Coeff. /°C ³ (all ranges)				0.10 + 0.004	0.030 + 0.004	0.005 + 0.003	0.006 + 0.005	0.006 + 0.005
			Accuracy: \pm (ppm of reading + offset ppm)						
Frequency ⁴ and Period				3 Hz–500 kHz	3 Hz–500 kHz	333 ms–2 μ s			
	100.0000 mV	0.333 ppm	90 Day/1 Year (all ranges)	80 + 0.333	80 + 0.333	(0.25 s gate)			
	to	3.33 ppm		80 + 3.33	80 + 3.33	(100 ms gate)			
300.0000 V	33.3 ppm	80 + 33.3		80 + 33.3	(10 ms gate)				

ADDITIONAL UNCERTAINTY \pm (% of reading)

Low Frequency Uncertainty	Detector Bandwidth			Additional Uncertainty \pm (% of reading)	Detector Bandwidth	Crest Factor ⁵ Maximum Crest Factor: 5 at full-scale			
	3 (3 Hz–300 kHz)	30 (30 Hz–300 kHz)	300 (300 Hz–300 kHz)			1–2	2–3	3–4	4–5
20 Hz–30 Hz	0	0.3	—	5 Hz–10 Hz	3	0.50	1.20	1.30	1.40
30 Hz–50 Hz	0	0	—	10 Hz–30 Hz	3	0.20	0.30	0.60	0.90
50 Hz–100 Hz	0	0	4.0	30 Hz–100 Hz	3 or 30	0.20	0.30	0.60	0.90
100 Hz–200 Hz	0	0	0.72	>100 Hz	3 or 30	0.05	0.15	0.30	0.40
200 Hz–300 Hz	0	0	0.18	300 Hz–500 Hz	300 only	0.50	1.20	1.30	1.40
300 Hz–500 Hz	0	0	0.07	≥ 500 Hz	300 only	0.05	0.15	0.30	0.40
>500 Hz	0	0	0						

1.888.KEITHLEY (U.S. only)

www.keithley.com

KEITHLEY

A GREATER MEASURE OF CONFIDENCE

Series 3700A

System Switch/Multimeter and Plug-In Cards

AC SPEEDS Single Channel, 60Hz (50Hz) Operation

Function	Detector Bandwidth	NPLC	Aperture (ms)	Measurements into Buffer ^a (rdg/s)			Measurement to PC ^a (ms/rdg)		
				Digits	Azero On	Azero Off	Ethernet	GPIO	USB
ACI / ACV	3	N/A	N/A	6½	0.45 (0.45)	N/A	2150 (2150)	2150 (2150)	2150 (2150)
	30	N/A	N/A	6½	2.5 (2.5)	N/A	400 (400)	400 (400)	400 (400)
	300	1.0 ¹⁰	16.67 (20)	6½	42 (33)	59.5 (50)	19.4 (22.7)	19.5 (22.8)	19.8 (23.1)
	300	0.2 ¹⁰	3.33 (4.0)	6½	120 (100)	295 (235)	7.6 (8.3)	6.2 (6.8)	6.4 (7.0)
	300	0.06 ¹¹	1.0 (1.2)	5½	170 (165)	935 (750)	1.40 (1.80)	1.50 (1.80)	1.60 (2.30)
	300	0.006 ¹¹	0.100 (0.120)	4½	218 (215)	6,200 (5,500)	0.55 (0.57)	0.65 (0.67)	0.75 (0.77)
300	0.0005 ¹¹	0.0083 (0.001)	3½	218 (215)	14,600 (14,250)	0.50 (0.5)	0.60 (0.60)	0.70 (0.70)	
Frequency/Period	N/A	N/A	10–273	N/A	2× input period + gate time	N/A	2× input period + gate time + 2.7ms	2× input period + gate time + 2.8ms	2× input period + gate time + 3.1ms

AC MEASUREMENT CHARACTERISTICS

AC VOLTS

MEASUREMENT METHOD: AC-coupled, True RMS.

INPUT IMPEDANCE: 1MΩ ±2% // by <150pF.

INPUT PROTECTION: 300VDC or 300Vrms rear inputs or 37xx cards.

AC CURRENT

MEASUREMENT METHOD: AC-coupled, True RMS.

Range	3 A	1 A	100 mA	10 mA	1 mA
Shunt Resistance guaranteed by design	0.05 Ω	0.05 Ω	1.0 Ω	10 Ω	100 Ω
Burden Voltage Rear Panel	<1.75 V rms	<0.55 V rms	<0.4 V rms	<150 mV rms	<125 mV rms
Burden Voltage 3721 Card	<2.4 V rms	<1.0 V rms	<0.6 V rms	<200 mV rms	<130 mV rms

INPUT PROTECTION: 3A, 250V fuse.

FREQUENCY AND PERIOD

MEASUREMENT METHOD: Reciprocal Counting technique.

GATE TIME: dmm.aperture=0.273→0.01. Default 0.01s.

AC GENERAL

AC CMRR⁶: 70dB.

VOLT-HERTZ PRODUCT: ≤8×10⁷ Volt-Hz (guaranteed by design), ≤2.1×10⁷ Volt-Hz verified. Input frequency verified for ≤3×10⁵ Hz.

AC NOTES

- 20% overrange on AC functions except 1% on 300V and 3.33% on 3A. Default resolution is 5½ digits, maximum useable resolution is 6½ with 7½ digits programmable.
- Specification are for Detector Bandwidth 3 and sinewave inputs >5% of range. Detector Bandwidth 3 and 30 are multi-sample A/D conversions. Detector bandwidth 300 is a single A/D conversion, programmable from 0.0005PLC to 15PLC. Default condition set to 1PLC.
- Applies to 0°–18°C and 28°–50°C.
- Specified for square wave inputs. Input signal must be >10% of ACV range. If input is <20mV on the 100mV range then the frequency must be >10Hz. For sinewave inputs, frequency must be >100Hz.
- Applies to non-sinewave inputs 5Hz→10kHz, and DC content ≤3% of range.
- For 1kΩ unbalance in LO lead.
- For Model 3721, 1mA ACI, add 0.05% to “of reading” uncertainty from 250Hz → 10kHz.
- Shunt resistance guaranteed by design.
- Reading rates are for 60Hz (50Hz) operation using factory defaults operating conditions dmm.reset(“all”), Autorange off, dmm.autodelay=dmm.OFF, dmm.opendetector=dmm.OFF, format.data=format.SREAL. Ranges as follows: DCV = 10V, 2WΩ/4WΩ = 1kΩ, DCI = 1mA, Dry-Ckt Ω = 10Ω, ACI = 1mA, and ACV = 1V. For Dry-Ckt Ω with Offset Comp OFF 2kΩ, 60 rdg/s max. Dry-Ckt Ω with Offset Comp ON 2kΩ, 29.5 rdg/s max. For temperature reading rates use DCV for T/C and 2WΩ for Thermistor. Speeds are typical and include measurements and data transfer out the Ethernet, GPIO, or USB.
- DMM configured for single reading, dmm.measurecount=1, and print(dmm.measure()). May require additional settling delays for full accuracy, depending on measurement configuration.
- DMM configured for multisample readings and single buffer transfer, dmm.measurecount=1000, buf=dmm.makebuffer(1000), dmm.measure(buf), and printbuffer(1,1000,buf).

1.888.KEITHLEY (U.S. only)

www.keithley.com

KEITHLEY

A GREATER MEASURE OF CONFIDENCE

GENERAL

EXPANSION SLOTS: 6.

POWER LINE: Universal, 100V to 240V.

LINE FREQUENCY: 50Hz and 60Hz, automatically sensed at power-up.

POWER CONSUMPTION: 28VA with DMM and display, up to 140VA with six 37xx cards.

REAL TIME CLOCK: Battery backed, 10 years typical life.

EMC: Conforms to European Union EMC Directive.

SAFETY: Conforms to European Union Low Voltage Directive.

VIBRATION: MIL-PRF-28800F Class 3, Random.

WARM-UP: 2 hours to rated accuracy.

DIGITAL I/O: 25-pin female D-shell.

	I/O 1-9	I/O 10-14	Vext
$I_{\text{SINK, max}}$	5 mA	250 mA	—
Absolute V_{IN}	5.25 V to -0.25 V	5.25 V to -0.25 V	5 V to 33 V
$V_{\text{IH min}}$	2.2 V	2.2 V	—
$V_{\text{IL max}}$	0.7 V	0.7 V	—
$V_{\text{OL max at 5mA } I_{\text{sink}}}$	0.7 V	0.7 V	—
$V_{\text{OL max at } I_{\text{sink max}}}$	—	2.3 V	—
$V_{\text{OH min, 0.4mA source}}$	2.7 V	2.4 V	—
Min $V_{\text{IN pulse}}$	2 μs	10 μs	—
Min $V_{\text{O pulse}}$	1 μs	50 μs	—

I/O 1-9

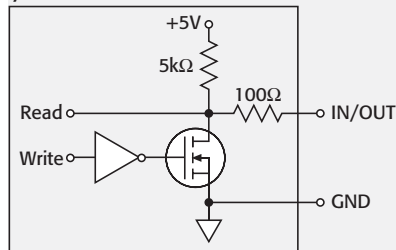

I/O 10-14

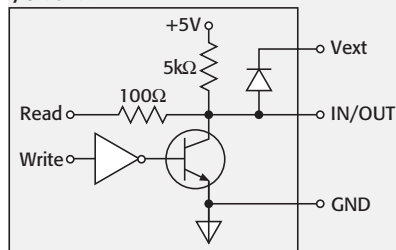

TRIGGERING AND MEMORY:

Window Filter Sensitivity: 0.01%, 0.1%, 1%, 10%, or full-scale of range (none).

Trigger Delay: 0 to 99 hrs. (10 μs step size).

External Trigger Delay: <10 μs .

Memory: Up to 650,000 time-stamped readings with Web page disabled. Additional memory available with external "thumb drive."

Non-volatile Memory: Single user save setup, with up to 75 DMM configurations and ≥ 600 channel patterns (dependent on name length, DMM function and configuration, and pattern image size). Additional memory available with external "thumb drive."

MATH FUNCTIONS: Rel, dB, Limit Test, %, 1/x, and mX+b with user defined displayed.

REMOTE INTERFACE:

Ethernet: RJ-45 connector, LXI Class B Version 2, 10/100BT, no auto MDIX.

GPIO: IEEE-488.1 compliant. Supports IEEE-488.2 common commands and status model topology.

USB Device (rear panel, type B): Full speed, USBTMC compliant.

USB Host (front panel, type A): USB 2.0, support for thumb drives.

LXI COMPLIANCE: LXI Class B Version 2 with IEEE 1588 precision time protocol.

LXI TIMING (applies to scanning) and SPECIFICATION:

Receive LAN[0-7] Event Delay: n/s (not specified) min., 800 μs typ., n/s max.

Alarm to Trigger Delay: 25 μs min., 50 μs typ., n/s max.

Generate LAN[0-7] Event: n/s min., 800 μs typ., n/s max. (minimums are probabilistic and represent a 95% confidence factor).

Clock Accuracy: 25ppm.

Synchronization Accuracy: <150ns (probabilistic and represents a 95% confidence factor).

Timestamp Accuracy: 100 μs .

Timestamp Resolution: 20ns.

LANGUAGE: Embedded Test Script Processor (TSP) accessible from any host interface.

Responds to individual Instrument Control Library (ICL) commands. Responds to high-speed test scripts comprised of ICL commands and Test Script Language (TSL) statements (e.g., branching, looping, math, etc.). Able to execute high-speed test scripts stored in memory without host intervention.

IP CONFIGURATION: Static or DHCP.

PASSWORD PROTECTION: 11 characters

MINIMUM PC HARDWARE: Intel Pentium 3, 800MHz, 512Mbyte RAM, 210Mbyte disk space or better.

OPERATING SYSTEMS/SOFTWARE: Windows® 2000 and XP compatible, supports Web browsers with Java plug-in (requires Java plug-in 1.6 or higher). Web pages served by 3706A.

OPERATING ENVIRONMENT: Specified for 0° to 50°C, $\leq 80\%$ RH at 35°C, altitude up to 2000 meters.

STORAGE ENVIRONMENT: -40° to 70°C.

DIMENSIONS:

Rack Mounted: 89mm high \times 483mm wide \times 457mm deep (3.5 in. \times 19 in. \times 18 in.).

Bench Configuration (includes handle and feet): 104mm high \times 483mm wide \times 457mm deep (4.125 in. \times 19 in. \times 18 in.)

SHIPPING WEIGHT: 13kg (28 lbs).

Series 3700A

- Multiplexer, matrix, and I/O cards
- Relay closures automatically counted and stored in each card's onboard memory
- Unlimited contact life with solid-state relay (Model 3724)
- Automatic CJC for temperature measurements when used with screw terminal accessory (Models 3720, 3721, 3724)

Ordering Information

3720	Dual 1×30 Multiplexer Card	148
3721	Dual 1×20 Multiplexer Card	150
3722	Dual 1×48, High Density, Multiplexer Card	152
3723	Dual 1×30, High Speed, Reed Relay, Multiplexer Card	154
3724	Dual 1×30 FET Multiplexer Card	156
3730	6×16, High Density, Matrix Card	159
3731	6×16, High Speed, Reed Relay, Matrix Card	161
3732	Quad 4×28, Ultra-High Density, Reed Relay, Matrix Card	163
3740	General Purpose Card with 32 Independent Channels	167
3750	Multifunction Control Card	169

Plug-in Cards for Series 3700A Mainframes

Specifications for Plug-In Cards

Additional Series 3700A cards are currently in development. For a current list of cards and specifications, visit www.keithley.com.

	3720	3721	3722
Page	148	150	152
No. of Channels	60 (Dual 1×30)	40 (dual 1×20)	96 (dual 1×48)
Card Config.	Multiplexer	Multiplexer	Multiplexer
Type of Relay	Latching electromechanical	Latching electromechanical	Latching electromechanical
Contact Configuration	2 Form A	2 Form A	2 Form A
Max. Voltage	300 V	300 V (ch 1–40), 60 V (ch 41–42)	300 V
Max. Current Switched	1 A	2 A (ch 1–40), 3 A (ch 41–42)	1 A
Comments	2 independent 1×30 multiplexers. Automatic temperature reference when used with screw terminal accessory (Model 3720-ST)	2 independent 1×20 multiplexers. Automatic temperature reference when used with screw terminal accessory (Model 3721-ST)	2 independent 1×48 multiplexers

Plug-in Card Accessories

	3720	3721	3722
Cables	3720-MTC-1.5, 3720-MTC-3	3721-MTC-1.5, 3721-MTC-3	3722-MTC-1.5, 3722-MTC-1.5/MM, 3722-MTC-3, 3722-MTC-3/MM
Screw Terminal Block	3720-ST	3721-ST	
Connector Kits	3791-KIT78-R	3790-KIT50-R	3792-KIT104-R, 3792-KIT104-R/F
Tools	3791-CIT		3791-CIT

1.888.KEITHLEY (U.S. only)

www.keithley.com

KEITHLEY

A GREATER MEASURE OF CONFIDENCE

Series 3700A

Plug-in Cards for Series 3700A Mainframes

3723	3724	3730	3731	3732	3740	3750
154	156	159	161	163	167	169
60 (dual 1×30) or 120 single pole (dual 1×60)	60 (dual 1×30)	6×16	6×16	448 crosspoints (Quad 4×28)	32	40 digital I/O, 4 counter/totalizers, and 2 isolated analog outputs
Multiplexer	Multiplexer	Matrix	Matrix	Matrix	Independent	Independent
Dry reed	FET solid-state	Latching electromechanical	Dry reed	Dry reed	Latching electromechanical	N/A
1 Form A	2 Form A	2 Form A	2 Form A	1 Form A	28 Form C, 4 Form A	N/A
200 V	200 V	300 V	200 V	200 V	300 VDC/250 VAC (Form A)	N/A
1 A	0.1 A	1 A	1 A	0.75 A	2 A (Form C), 7 A (Form A)	N/A
2 independent 1×30 multiplexers	2 independent 1×30 multiplexers. Automatic temperature reference when used with screw terminal accessory (Model 3724-ST)	Columns can be expanded through the backplane or isolated by relays	Relay actuation time of 0.5ms. Columns can be expanded through the backplane or isolated by relays	Banks can be connected together via bank configuration relays to create a single 4×112 or dual 4×56 matrix. Analog backplane relays also included for card to card expansion. Row expansion with 3732-ST-R accessory to create a dual 8×28 or single 16×28 matrix.	32 general purpose independent channels.	All-in-one card design. 40 bidirectional I/O. Four 32-bit counter/totalizers. 2 programmable analog (V or I) outputs.

3723	3724	3730	3731	3732	3740	3750
3720-MTC-1.5, 3720-MTC-3	3720-MTC-1.5, 3720-MTC-3	3721-MTC-1.5, 3721-MTC-3	3721-MTC-1.5, 3721-MTC-3	3732-MTC-1.5, 3732-MTC-3	3721-MTC-1.5, 3721-MTC-3	3721-MTC-1.5, 3721-MTC-3
3723-ST, 3723-ST-1	3724-ST	3730-ST	3731-ST	3732-ST-C, 3732-ST-R	3740-ST	3750-ST
3791-KIT78-R	3791-KIT78-R	3790-KIT50-R	3790-KIT50-R	3791-KIT78-R	3790-KIT50-R	3790-KIT50-R
3791-CIT	3791-CIT			3791-CIT		

Plug-in cards for Series 3700A mainframes

SWITCHING AND CONTROL

1.888.KEITHLEY (U.S. only)
www.keithley.com

KEITHLEY

A GREATER MEASURE OF CONFIDENCE

3720

Dual 1×30 Multiplexer Card

60 differential channels, automatic CJC w/3720-ST accessory

- 60 two-pole channels or 30 four-pole channels for general purpose switching
- Automatic CJC for temperature measurements when used with 3720-ST accessory
- Analog backplane connection relays provide easy bank and card interconnections
- 300V, 1A switched or 2A carry signal capacity; 60W, 125VA
- Screw terminal connections provided with removable 3720-ST accessory
- Relay closures stored in onboard memory
- Latching electromechanical relays

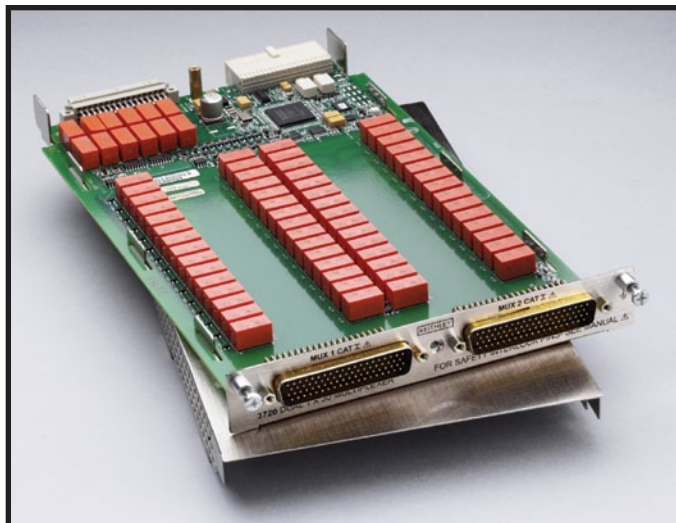

The Model 3720 offers two independent banks of 1×30 two-pole multiplexers. It is ideal for general purpose switching, including temperature measurements. The two banks can automatically be connected to the Series 3700A mainframe backplane and optional DMM through the analog backplane connection relays. This connection allows the mainframe to reconfigure the card to a single 1×60 two-pole multiplexer or to enable card-to-card expansion for even larger configurations.

Other features of the Model 3720 include its ability to be reconfigured to coordinated four-pole operation for additional measurement flexibility. Furthermore, the Model 3720 supports thermocouple-type temperature measurements when used with the Model 3720-ST (screw terminal) accessory providing automatic cold junction compensation (CJC).

The Model 3720 uses two 78-pin male D-sub connectors for signal connections. For screw terminal or automatic CJC, use the detachable Model 3720-ST accessory.

Ordering Information

3720 **Dual 1×30
Multiplexer Card**

ACCESSORIES AVAILABLE

3720-MTC-1.5	78 Pin D-sub Female to Male Cable, 1.5m (5 ft.)
3720-MTC-3	78 Pin D-sub Female to Male Cable, 3m (10 ft.)
3720-ST	Screw Terminal Block (required for auto CJC thermocouple measurements)
3791-CIT	Contact Insertion and Extraction Tool
3791-KIT78-R	78 Pin Female D-sub Connector Kit (contains 2 female D-sub connectors and 156 solder-cup contacts)
7401	Type K Thermocouple Wire (100 ft.)

SERVICES AVAILABLE

3720-3Y-EW-STD	1-year factory warranty extended to 3 years from date of shipment
3720-5Y-EW-STD	1-year factory warranty extended to 5 years from date of shipment
C/3720-3Y-STD	3 (Z540-1 compliant) calibrations within 3 years of purchase*

*Not available in all countries

Dual 1×30 Multiplexer Card

60 differential channels, automatic CJC w/3720-ST accessory

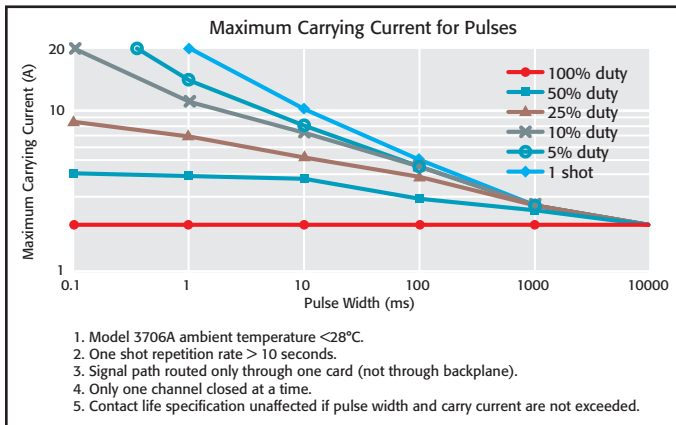
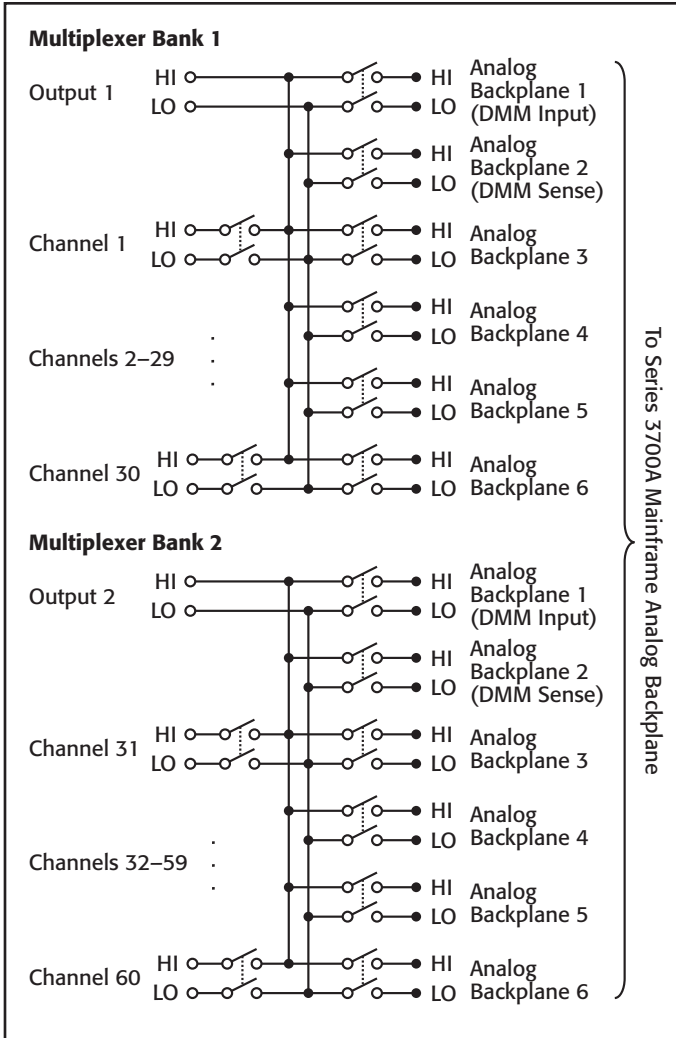

MULTIPLEXER CONFIGURATION: Two independent 1×30 2-pole multiplexers. Banks can be isolated from the backplane by relays. Card can be configured for 2 and 4 wire.

CONTACT CONFIGURATION: 2 pole form A.

CONNECTOR TYPE: Two 78 pin male D-shells.

MODEL 3720-ST SCREW TERMINAL OPTION: #22 AWG typical wire size with 0.062 inch O.D. 124 conductors maximum. #16 AWG maximum wire size with 0.092 inch O.D. 36 conductors per card maximum.

MAXIMUM SIGNAL LEVEL: Channels 1–60: 300V DC or RMS, 1A switched (2A carry), 60W, 125VA.

COMMON MODE VOLTAGE: 300V DC or RMS between any terminal and chassis.

VOLT-HERTZ LIMIT: 8×10⁷.

CONTACT LIFE: >10⁵ operations at maximum signal level. >10⁸ operations no load.¹

	Dual 1×30 ³	Single 1×60 ^{2,3}
Channel Resistance (end of contact life)	<1.0 Ω	<1.5 Ω
Contact Potential (differential)	<±1 μV	<±3 μV
Offset Current	<±250 pA	<±250 pA
Isolation		
Differential	10 ⁹ Ω, 250 pF	10 ⁹ Ω, 450 pF
Bank-Bank	10 ¹⁰ Ω, 75 pF	—
Channel-channel	10 ⁹ Ω, 75 pF	10 ⁹ Ω, 75 pF
Common Mode	10 ⁹ Ω, 200 pF	10 ⁹ Ω, 400 pF
Crosstalk Channel-channel		
300kHz	<-60 dB	<-55 dB
1MHz	<-50 dB	<-50 dB
20MHz:	<-25 dB	<-20 dB
Bandwidth	30 MHz	10 MHz

TYPICAL SCANNING SPEEDS:

Switch Only⁴: Sequential scanning, single channel, immediate trigger advance: >120 ch/s.

With Measurements Into Memory⁵:

DCV (10V range) or 2W Ohms (1kΩ range): >110 ch/s.

Thermocouple: >110 ch/s.

3- or 4-Wire RTD: >100 ch/s.

4-Wire Ohms (1kΩ range): >100 ch/s.

ACV (10V range): >110 ch/s.

GENERAL

ACTUATION TIME: 4ms.

TEMPERATURE ACCURACY using Automatic CJC with 3720-ST accessory: 1°C for J, K, T and E types (see mainframe specification for details).

RELAY TYPE: Latching electromechanical.

RELAY DRIVE SCHEME: Matrix.

INTERLOCK: Backplane relays disabled when interlock connection is removed.

OPERATING ENVIRONMENT: Specified for 0° to 50°C. Specified to 70% R.H. at 35°C.

STORAGE ENVIRONMENT: -25° to 65°C.

WEIGHT: 2.5 lbs.

SAFETY: Conforms to European Union Directive 73/23/EEC, EN61010-1.

EMC: Conforms to European Union Directive 2004/108/EC, EN61326-1.

NOTES

- Open detector enabled during thermocouple measurements. Minimum signal level 10mV, 10μA.
- 3706A mainframe with all DMM backplane relays disconnected. Maximum two card backplane relays closed.
- Connections made using 3720-ST accessory.
- Scanning script local to 3706A mainframe, within same bank, and break before make switching.
- 3706A mainframe with autorange off, limits off, dmm.autozero=0, dmm.autodelay=0, 4½ digits (NPLC=0.006), for ACV dmm.detectorbandwidth=300, for OHMS dmm.offsetcompensation=off, dmm.opendetector=off. Scanning script local to mainframe, sequential scan within same bank (2 pole) or card (4 pole), and break before make switching.

3721

Dual 1×20 Multiplexer Card

40 differential channels, automatic CJC w/3721-ST accessory

- 40 two-pole or 20 four-pole channels for general purpose switching
- 2 dedicated channels for current measurements, 3A capacity
- Automatic CJC for temperature measurements when used with 3721-ST accessory
- 4-wire common side ohms input supports 40 channels of 4-wire ohms measurements
- Analog backplane connection relays provide easy bank and card interconnections
- 300V, 2A switched or 3A carry signal capacity; 60W, 125VA
- Latching electromechanical relays

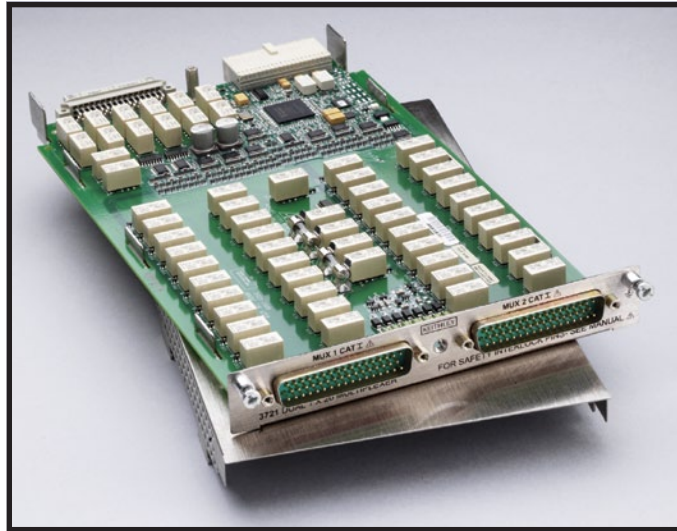

The Model 3721 offers two independent banks of 1×20 two-pole multiplexers that are ideal for general purpose switching, including temperature measurements. The two banks can automatically be connected to the Series 3700A mainframe backplane and optional DMM through the analog backplane connection relays. This connection allows the mainframe to reconfigure the Model 3721 as a single 1×40 two-pole multiplexer or to enable card-to-card expansion for even larger configurations.

The Model 3721 provides a number of other features. In addition to the 40 channels, two fused channels are supplied for current measurements. Also, the Model 3721 includes dedicated inputs that enable 40 channels of four-wire common side ohms measurements. For thermocouple type measurements, automatic cold junction compensation (CJC) is supported when used with the Model 3721-ST (screw terminal) accessory.

The Model 3721 uses two 50-pin male D-sub connectors for signal connections. For screw terminal or automatic CJC, use the detachable Model 3721-ST accessory.

Ordering Information

3721 Dual 1×20 Multiplexer Card

ACCESSORIES AVAILABLE

3721-MTC-1.5	50 Pin D-sub Female to Male Cable, 1.5m (5 ft.)
3721-MTC-3	50 Pin D-sub Female to Male Cable, 3m (10 ft.)
3721-ST	Screw Terminal Block (required for auto CJC thermocouple measurements)
3790-KIT50-R	50 Pin Female D-sub Connector Kit (contains 2 female D-sub connectors and 100 solder-cup contacts)
7401	Type K Thermocouple Wire (100 ft.)

SERVICES AVAILABLE

3721-3Y-EW-STD	1-year factory warranty extended to 3 years from date of shipment
3721-5Y-EW-STD	1-year factory warranty extended to 5 years from date of shipment
C/3721-3Y-STD	3 (Z540-1 compliant) calibrations within 3 years of purchase*

*Not available in all countries

1.888.KEITHLEY (U.S. only)

www.keithley.com

KEITHLEY

A GREATER MEASURE OF CONFIDENCE

Dual 1×20 Multiplexer Card

40 differential channels, automatic CJC w/3721-ST accessory

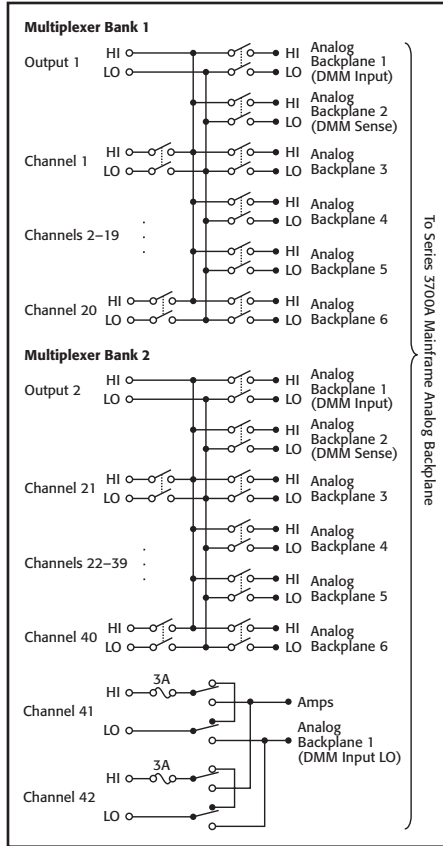

Two pole mode

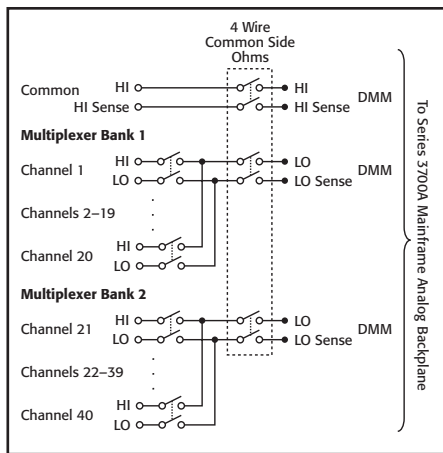

Four-wire common side ohm mode

MULTIPLEXER CONFIGURATION: Two independent 1×20 2-pole multiplexers. Banks can be connected together via relay creating a single 1×40 multiplexer. Banks can be isolated from the backplane by relays. Card can be configured for common side Ohms measurement via backplane relays. **Channel 41–42:** Multiplex one of two 2-pole current signals into DMM.

CONTACT CONFIGURATION: 2 pole form A.

CONNECTOR TYPE: Two 50 pin male D-shells. Removable screw terminal option.

MAXIMUM SIGNAL LEVEL: **Channels 1–40:** 300V DC or RMS, 2A switched (3A carry), 60W, 125VA maximum. **Channels 41–42:** 60V DC or 30V RMS, 3A switched, 60W, 125VA maximum. Fused 3A, 250V RMS.

COMMON MODE VOLTAGE: **Channels 1–40:** 300V DC or RMS between any terminal and chassis.

VOLT-HERTZ LIMIT: 8×10⁷.

CONTACT LIFE: >10⁵ operations at maximum signal level. >10⁶ operations no load.¹

TYPICAL SCANNING SPEEDS:

Switch Only⁴: Sequential scanning, single channel, immediate trigger advance: >120 ch/s.

With Measurements Into Memory⁵:

DCV (10V range) or 2W Ohms (1kΩ range): >110 ch/s

Thermocouple: >110 ch/s.

3- or 4-Wire RTD: >100 ch/s.

4-Wire Ohms (1kΩ range): >100 ch/s.

ACV (10V, 400Hz range) or ACI (1A, 400Hz range): >110 ch/s.

NOTES

- Open detector enabled during thermocouple measurements. Minimum signal level 10mV, 10μA.
- 3706A mainframe with all DMM backplane relays disconnected. Maximum two card backplane relays closed.
- Connections made using 3721-ST accessory.
- Scanning script local to 3706A mainframe, within same bank, and break before make switching.
- 3706A mainframe with autorange off, limits off, dmm.autozero=0, dmm.autodelay=0, 4½ digits (NPLC=0.006), for ACV dmm.detectorbandwidth=300, for OHMS dmm.offsetcompensation=off, dmm.opendetector=off. Scanning script local to mainframe, sequential scan within same bank (2 pole) or card (4 pole), and break before make switching.

	Dual 1×20 ³	Single 1×40 ^{2,3}
Channel Resistance (end of contact life)	<1.0 Ω	<1.5 Ω
Contact Potential (differential)	<±1 μV	<±3 μV
Offset Current	<±250 pA	<±250 pA
Isolation		
Differential	10 ⁹ Ω, 280 pF	10 ⁹ Ω, 530 pF
Bank-Bank	10 ¹¹ Ω, 60 pF	—
Channel-channel	10 ⁹ Ω, 50 pF	10 ⁹ Ω, 50 pF
Common Mode	10 ⁹ Ω, 180 pF	10 ⁹ Ω, 480 pF
Crosstalk Channel-channel		
300kHz	<-60 dB	<-60 dB
1MHz	<-50 dB	<-50 dB
20MHz	<-25 dB	<-15 dB
Bandwidth	28 MHz	9 MHz

GENERAL

ACTUATION TIME: 4ms.

TEMPERATURE ACCURACY using Automatic CJC with 3721-ST accessory: 1°C for J, K, T, and E types (see mainframe specification for details).

RELAY TYPE: Latching electromechanical.

RELAY DRIVE SCHEME: Direct.

INTERLOCK: Backplane relays disabled when interlock connection is removed.

OPERATING ENVIRONMENT: Specified for 0° to 50°C. Specified to 70% R.H. at 35°C.

STORAGE ENVIRONMENT: -25° to 65°C.

WEIGHT: 2.25 lbs.

SAFETY: Conforms to European Union Directive 73/23/EEC, EN61010-1.

EMC: Conforms to European Union Directive 2004/108/EC, EN61326-1.

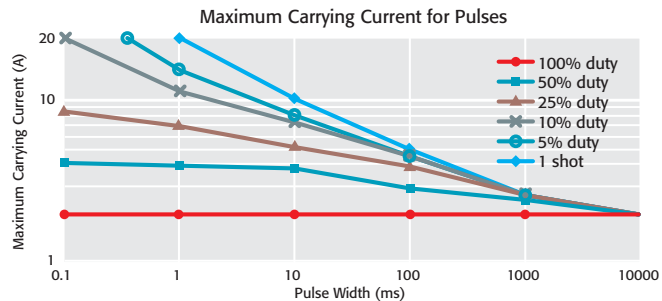

- Model 3706A ambient temperature <28°C.
- One shot repetition rate > 10 seconds.
- Signal path routed only through one card (not through backplane).
- Only one channel closed at a time.
- Contact life specification unaffected if pulse width and carry current are not exceeded.

3722

Dual 1×48, High Density, Multiplexer Card 96 differential channels, 300 Volts/1 Amp

- 96 two-pole or 48 four-pole channels for general purpose measurements
- Analog backplane connection relays provide easy bank and card interconnections
- 300V, 1A switched or 2A carry signal capacity; 60W, 125VA
- 1μV and 100pA offsets
- 25MHz bandwidth
- Relay closures stored in onboard memory
- Latching electromechanical relays
- Scan and measure over 110 channels/second

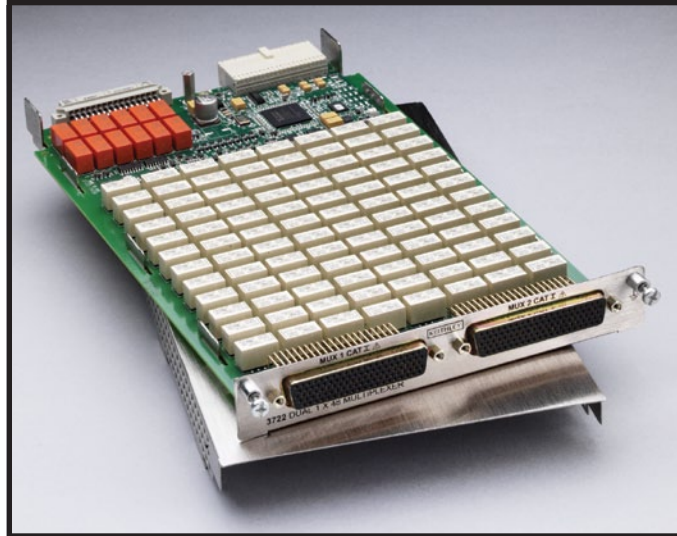

The Model 3722 offers two independent banks of 1×48 two-pole multiplexers, which is ideal for applications that require a high channel count. The two banks can automatically be connected to the Series 3700A mainframe backplane and optional DMM through the analog backplane connection relays. This connection allows the mainframe to reconfigure the card as a single 1×96 two-pole multiplexer or to enable card-to-card expansion for even larger configurations. Another feature of this card is the latching electromechanical relays. They can accommodate 300V, 1A switched signal levels.

The Model 3722 uses two 104-pin D-sub connectors for signal connections. A solder style connector kit (Model 3792-KIT104-R) and pre-assembled cables (Model 3722-MTC-1.5 and 3722-MTC-3) are available for card connections.

Ordering Information

3722 Dual 1×48, High Density, Multiplexer Card

ACCESSORIES AVAILABLE

3722-MTC-1.5	104-pin D-sub Male to Female Cable, 1.5m (5 ft.)
3722-MTC-1.5/MM	104-pin D-sub Male to Male Cable, 1.5m (5 ft.)
3722-MTC-3	104-pin D-sub Male to Female Cable, 3m (10 ft.)
3722-MTC-3/MM	104-pin D-sub Male to Male Cable, 3m (10 ft.)
3791-CIT	Contact Insertion and Extraction Tool
3792-KIT104-R	104-pin Male D-sub Connector kit (contains 2 male D-sub connectors with housings and 208 solder-cup contacts)
3792-KIT104-R/F	104-pin Female D-sub Connector kit (contains 2 female D-sub connectors with housings and 208 solder-cup contacts)

SERVICES AVAILABLE

3722-3Y-EW-STD	1-year factory warranty extended to 3 years from date of shipment
3722-5Y-EW-STD	1-year factory warranty extended to 5 years from date of shipment
C/3722-3Y-STD	3 (Z540-1 compliant) calibrations within 3 years of purchase*

*Not available in all countries

Dual 1×48, High Density, Multiplexer Card

96 differential channels, 300 Volts/1 Amp

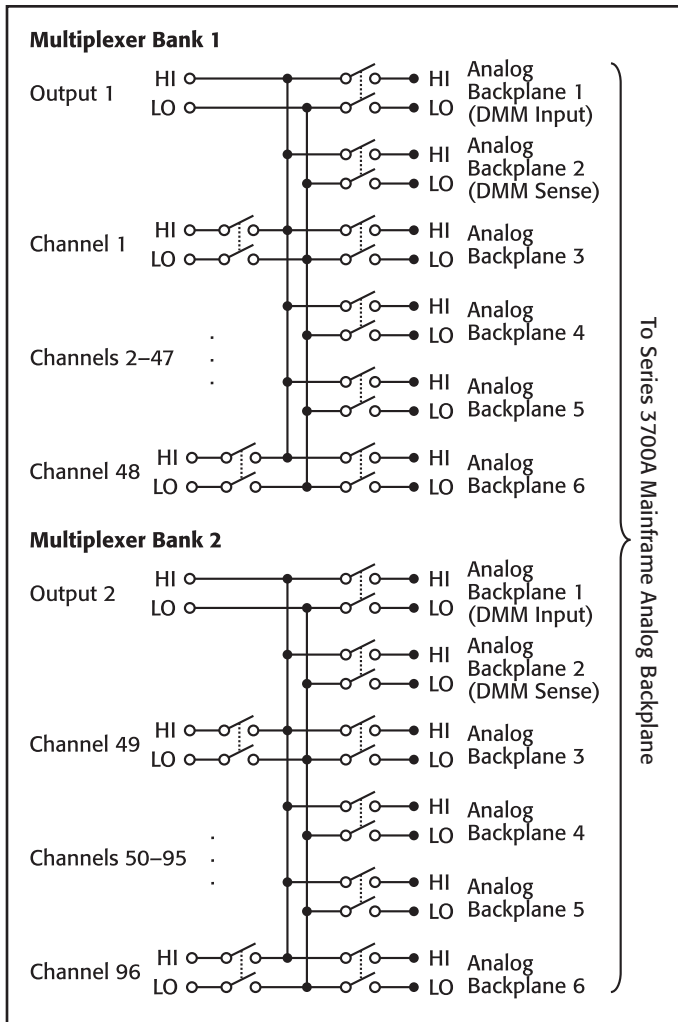

MULTIPLEXER CONFIGURATION: Two independent 1×48 2-pole multiplexers. Banks can be connected together via relays creating a single 1×96 multiplexer. Banks can be isolated from the backplane by relays. Card can be configured for 2- and 4-wire mode.

CONTACT CONFIGURATION: 2 pole form A.

CONNECTOR TYPE: Two 104 pin female D-shells.

MAXIMUM SIGNAL LEVEL: 300V DC or RMS, 1A switched (2A carry), 60W, 125VA.

COMMON MODE VOLTAGE: 300V DC or RMS between any terminal and chassis.

VOLT-HERTZ LIMIT: 8×10⁷.

CONTACT LIFE: >10⁵ operations at maximum signal level. >10⁸ operations no load.¹

	Dual 1×48 ²	Single 1×96
Channel Resistance (end of contact life)	<1.5 Ω	<2.5 Ω
Contact Potential (differential)	<±1 μV	<±2 μV
Offset Current	<100 pA	<100 pA
Isolation		
Differential	5×10 ⁹ Ω, 200 pF	5×10 ⁹ Ω, 400 pF
Bank-Bank	10 ⁹ Ω, 50 pF	—
Channel-channel	10 ⁹ Ω, 50 pF	10 ⁹ Ω, 50 pF
Common Mode	10 ¹⁰ Ω, 200 pF	10 ¹⁰ Ω, 400 pF
Crosstalk Channel-channel		
300kHz	<-65 dB	<-65 dB
1MHz	<-55 dB	<-55 dB
20MHz	<-30 dB	<-30 dB
Bandwidth	25 MHz	15 MHz

TYPICAL SCANNING SPEEDS:

Switch Only³: Sequential scanning, single channel, immediate trigger advance: >120 ch/s.

With Measurements Into Memory⁴:

DCV (10V range) or 2W Ohms (1kΩ range): >110 ch/s.

3- or 4-Wire RTD: >100 ch/s.

4-Wire Ohms (1kΩ range): >100 ch/s.

ACV (10V, 400Hz range): >110 ch/s.

GENERAL

ACTUATION TIME: 4ms.

RELAY TYPE: Latching electromechanical.

RELAY DRIVE SCHEME: Matrix.

OPERATING ENVIRONMENT: Specified for 0° to 50°C. Specified to 70% R.H. at 35°C.

STORAGE ENVIRONMENT: -25° to 65°C.

WEIGHT: 2.5 lbs.

SAFETY: Conforms to European Union Directive 73/23/EEC, EN61010-1.

EMC: Conforms to European Union Directive 2004/108/EC, EN61326-1.

NOTES

- Minimum signal level 10mV, 10μA.
- 3706A mainframe with all DMM backplane relays disconnected. Maximum two card backplane relays closed.
- Scanning script local to 3706A mainframe, within same bank, and break before make switching.
- 3706A mainframe with autorange off, limits off, dmm.autozero=0, dmm.autodelay=0, 4½ digits (NPLC=.006), for ACV dmm.detectorbandwidth=300, for OHMs dmm.offsetcompensation=off. Scanning script local to mainframe, sequential scan within same bank (2 pole) or card (4 pole), and break before make switching.

3723

Dual 1×30, High Speed, Multiplexer Card

60 differential channels, long life reed relays

- 60 two-pole or 30 four-pole channels for high speed scanning
- 120 channel single-pole mode for one-wire (common side) measurements
- Analog backplane connection relays provide easy bank and card interconnections
- 200V, 1A switched or 1.25A carry signal capacity; 15W
- Relay actuation time <0.5ms
- 20MHz bandwidth
- Ideal for multi-channel I-V testing with Series 2600A SourceMeter® instruments
- Long life dry reed relays (>10⁹ operations)

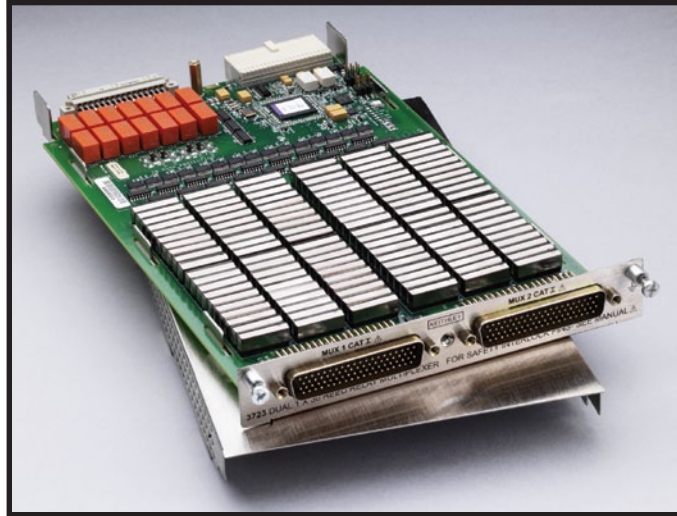

The Model 3723 offers two independent banks of high speed 1×30 two-pole multiplexers that are ideal for high speed scanning applications. The two banks can automatically be connected to the Series 3700A mainframe backplane and optional DMM through the analog backplane connection relays. This connection allows the mainframe to reconfigure the Model 3723 as a single 1×60 two-pole multiplexer or as a single 1×120 single-pole multiplexer. It also enables card-to-card expansion for even larger configurations.

By using high speed reed relays with actuation times of less than 0.5ms, this card can meet demanding throughput applications. Another feature of the Model 3723 is its single-ended, one-pole mode, which supports up to 120 channels of single-wire measurements.

The Model 3723 uses two 78-pin D-sub connectors for signal connections. For screw terminal connections, use the Model 3723-ST for two- and four-pole configurations or the Model 3723-ST-1 for single-wire applications.

Ordering Information

3723 Dual 1×30, High Speed, Reed Relay, Multiplexer Card

ACCESSORIES AVAILABLE

3720-MTC-1.5	78 Pin D-sub Female to Male Cable, 1.5m (5 ft.)
3720-MTC-3	78 Pin D-sub Female to Male Cable, 3m (10 ft.)
3723-ST	Screw Terminal Block
3723-ST-1	Screw Terminal Block for single-pole applications
3791-CIT	Contact Insertion and Extraction Tool
3791-KIT78-R	78 Pin Female D-sub Connector Kit (contains 2 female D-sub connectors and 156 solder-cup contacts)

SERVICES AVAILABLE

3723-3Y-EW-STD	1-year factory warranty extended to 3 years from date of shipment
3723-5Y-EW-STD	1-year factory warranty extended to 5 years from date of shipment
C/3723-3Y-STD	3 (Z540-1 compliant) calibrations within 3 years of purchase*

*Not available in all countries

Dual 1×30, High Speed, Multiplexer Card

60 differential channels, long life reed relays

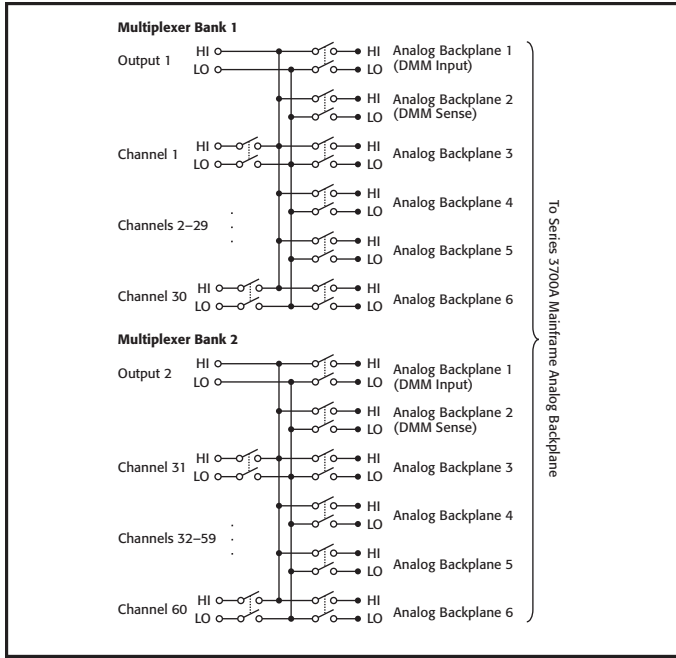

Two-pole mode

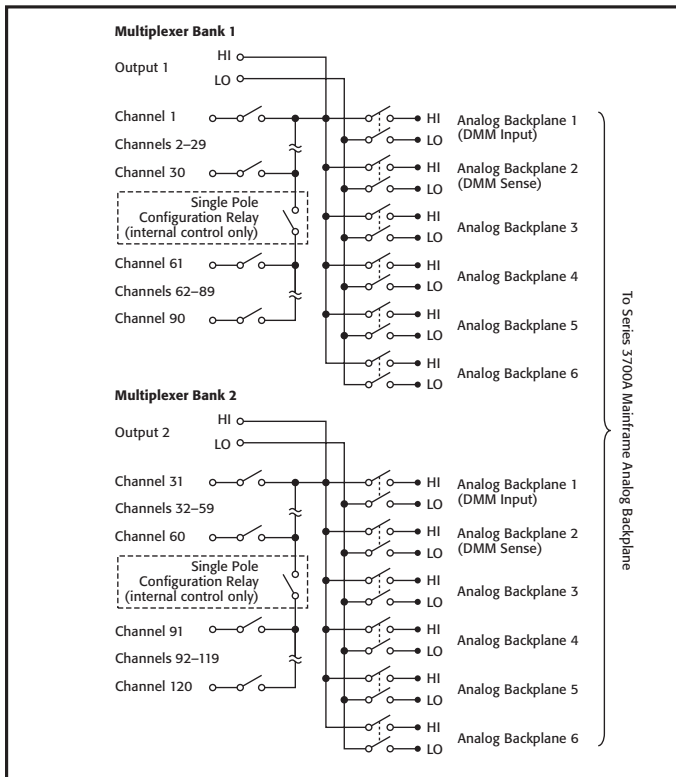

Single-pole mode

MULTIPLEXER CONFIGURATION: Two independent 1×30 2-pole multiplexers. Banks can be connected together via relay creating a single 1×60 multiplexer. Banks can be isolated from the backplane by relays. Card can be configured for 1-, 2-, and 4-wire.

CONTACT CONFIGURATION: 2 pole form A.

CONNECTOR TYPE: Two 78-pin male D-shells.

MODEL 3723-ST SCREW TERMINAL OPTION: #22 AWG typical wire size with 0.062 inch O.D. 124 conductors maximum. #16 AWG maximum wire size with 0.092 inch O.D. 36 conductor per card maximum.

MAXIMUM SIGNAL LEVEL: 200V DC or RMS, 1A switched (1.25A carry), 15W.

COMMON MODE VOLTAGE: 300V DC or RMS between any terminal and chassis.

VOLT-HERTZ LIMIT: 8×10⁷.

CONTACT LIFE: Reed: >10⁹ operations, no load. 10⁷ operations @ 100V, 10mA.

EMR: >10⁸ operations @ 5V, 10mA. 10⁵ operations @ maximum signal level.

	Dual 1×30 ¹	Single 1×60 ^{1,2}
Channel Resistance (end of contact life)	<1.5 Ω	<2.0 Ω
Contact Potential: Differential	<±6 μV	<±6 μV
Single-Ended	<±12 μV	<±12 μV
Offset Current	<250 pA	<250 pA
Isolation		
Differential	10 ¹⁰ Ω, 260 pF	10 ¹⁰ Ω, 500 pF
Bank-Bank	10 ¹⁰ Ω, 75 pF	—
Channel-channel	10 ¹⁰ Ω, 75 pF	10 ¹⁰ Ω, 75 pF
Common Mode	10 ¹⁰ Ω, 280 pF	10 ⁹ Ω, 625 pF
Crosstalk Channel-channel		
300kHz	<-55 dB	<-55 dB
1MHz	<-50 dB	<-45 dB
20MHz	<-20 dB	<-20 dB
Bandwidth	20 MHz	10 MHz

TYPICAL SCANNING SPEEDS:

Switch Only³: Sequential scanning, single channel, immediate trigger advance: >1000 ch/s.

With Measurements Into Memory⁴:

DCV (10V range) or 2W Ohms (1kΩ range): >800 ch/s.

3- or 4-Wire RTD: >450 ch/s.

4-Wire Ohms (1kΩ range): >450 ch/s.

ACV (10V, 400Hz range): >800 ch/s.

GENERAL

ACTUATION TIME: <0.5ms.

RELAY TYPE: Dry reed.

RELAY DRIVE SCHEME: Direct.

RELAY DRIVE CURRENT: 10mA.

INTERLOCK: Backplane relays disabled when interlock connection is removed.

OPERATING ENVIRONMENT: Specified for 0° to 50°C. Specified to 70% R.H. at 35°C.

STORAGE ENVIRONMENT: -25° to 65°C.

WEIGHT: 3.0 lbs.

SAFETY: Conforms to European Union Directive 73/23/EEC, EN61010-1.

EMC: Conforms to European Union Directive 2004/108/EC, EN61326-1.

NOTES

- Connections made using 3723-ST accessory.
- 3706A mainframe with all DMM backplane relays disconnected. Maximum two card backplane relays closed.
- Scanning script local to 3706A mainframe, within same bank, and break before make switching.
- 3706A mainframe with autorange off, limits off, dmm.autozero=0, dmm.autodelay=0, 4½ digits (NPLC=0.006), for ACV dmm.detectorbandwidth=300, for OHMS dmm.offsetcompensation=off. Scanning script local to mainframe, sequential scan within same bank (2 pole) or card (4 pole), and break before make switching.

3724

Dual 1×30 FET Multiplexer Card

60 differential channels, automatic CJC with 3724-ST accessory

- 60 two-pole or 30 four-pole solid-state channels
- Scanning speeds greater than 1250 channels/second (switch only)
- Optically isolated, solid-state FET relays provide unlimited contact life
- 200V, 0.1A switch/carry signal capacity; 800mW
- Automatic CJC for temperature measurements when used with 3724-ST accessory
- Analog backplane connection relays provide easy bank and card interconnections
- Screw terminal connections provided with removable 3724-ST accessory
- Ideal for maintenance-free, long-life thermocouple temperature measurements

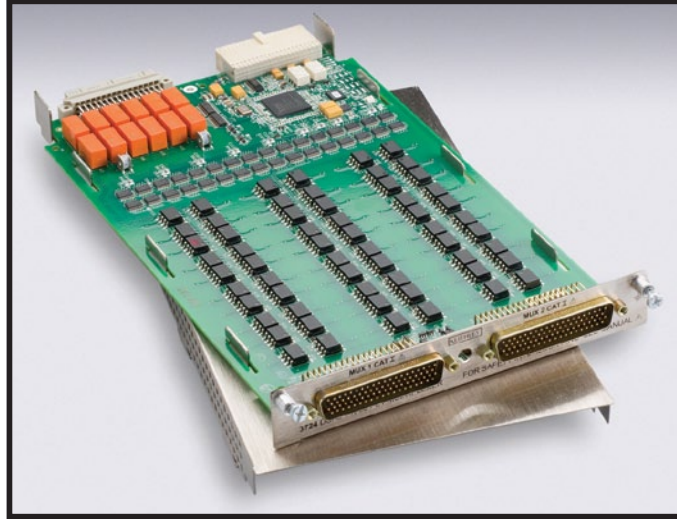

The Model 3724 provides two independent banks of solid-state relays arranged as 1×30 two-pole multiplexers that are ideal for high reliability, high speed multipoint measurement applications including temperature. The two banks can automatically be connected to the Series 3700A mainframe backplane and optional DMM through the analog backplane connection relays. This connection allows the mainframe to reconfigure the card to a single 1×60 two-pole multiplexer or to enable card-to-card expansion for even larger configurations.

The solid-state FET relay technology supports fast switching times with scanning rates of greater than 1250 channels/second and provides unlimited contact life. In addition, the Model 3724 supports thermocouple temperature measurements when used with the Model 3724-ST (screw terminal) accessory providing automatic cold junction compensation (CJC).

The Model 3724 uses two 78-pin male D-sub connectors for signal connections. For screw terminal or automatic CJC, use the detachable Model 3724-ST accessory.

ACCESSORIES AVAILABLE

3720-MTC-1.5	78-pin female-to-male D-sub Cable Assembly, 1.5m (4.9 ft)
3720-MTC-3	78-pin female-to-male D-sub Cable Assembly, 3m (9.8 ft)
3724-ST	Screw Terminal Block (required for auto CJC thermocouple measurements)
3791-CIT	Contact Insertion and Extraction Tool
3791-KIT78-R	78-pin female D-sub Connector Kit (contains 2 female D-sub connectors and 156 solder-cup contacts)

SERVICES AVAILABLE

3724-3Y-EW-STD	1-year factory warranty extended to 3 years from date of shipment
3724-5Y-EW-STD	1-year factory warranty extended to 5 years from date of shipment
C/3724-3Y-DATA	3 (Z540-1 compliant) calibrations within 3 years of purchase*

*Not available in all countries

Ordering Information

3724 Dual 1×30 FET Multiplexer Card

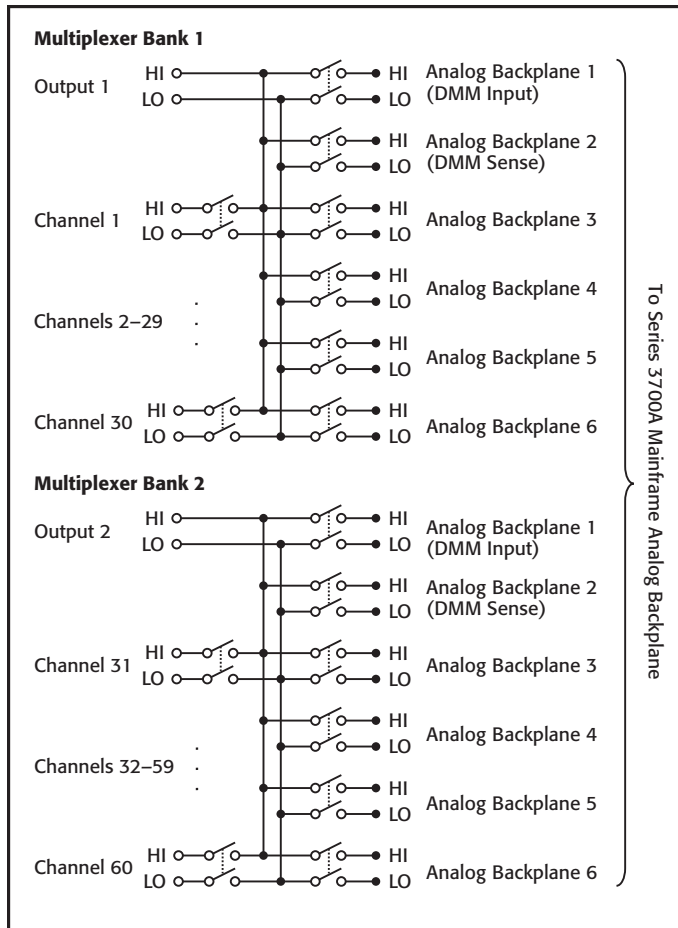

Model 3724 Specifications

MULTIPLEXER CONFIGURATION: Two independent 1×30, 2-pole multiplexers. Banks can be connected together via relay creating a single 1×60 multiplexer. Banks can be isolated from the backplane by relays. Card can be configured for 2- and 4-wire.

CONTACT CONFIGURATION: 2-pole form A.

CONNECTOR TYPE: Two 78-pin male D-shells.

MODEL 3724-ST SCREW TERMINAL OPTION: #22AWG typical wire size with 0.062 inch O.D. 124 conductors maximum. 16 AWG maximum wire size with 0.092 inch O.D. 36 conductor per card maximum.

MAXIMUM SIGNAL LEVEL: 200V DC or 141V RMS between any terminal, 0.1A switched (0.1A carry), 800mW.

COMMON MODE VOLTAGE: 300V DC or RMS between any terminal and chassis.

VOLT-HERTZ LIMIT: 10⁷.

CONTACT LIFE:

Solid State: > unlimited.

EMR (Backplane): >1×10⁸ operations @ 5V, 10mA.

1×10⁵ operations @ max. signal level.

	Dual 1×30 ¹	Single 1×60 ^{1,2}
Channel Resistance	<62Ω (54Ω @ 23°C)	<64Ω (58Ω @ 23°C)
Contact Potential (differential)	<±2 μV	<±2.5 μV
Offset Current	<10 nA (<±100 pA @ 23°C/60% R.H.)	<10 nA (<±100 pA @ 23°C/60% R.H.)
Isolation		
Differential	10 ⁹ Ω, 500 pF	10 ⁹ Ω, 1100 pF
Bank-Bank	10 ⁹ Ω, 100 pF	—
CH-CH	10 ⁹ Ω, 125 pF	10 ⁹ Ω, 125 pF
Common Mode	10 ⁹ Ω, 150 pF	10 ⁹ Ω, 700 pF
Crosstalk CH-CH		
300 kHz	-40 dB	-40 dB
1 MHz	-30 dB	-30 dB
Bandwidth	2 MHz	1 MHz

NOTES

1. Connections made using 3724-ST.

2. 3706A mainframe with all DMM backplane relays disconnected. Maximum two card backplane relays closed.

3724

Dual 1×30 FET Multiplexer Card

60 differential channels, automatic CJC with 3724-ST accessory

3724 Card/3706A Multimeter Condensed Specifications

TEMPERATURE

Displayed in °C, °F, or K. Exclusive of probe errors.

Displayed in °C, °F, or K. Exclusive of probe errors.

THERMOCOUPLES (accuracy based on ITS-90)

Type	Range	Resolution	90 Day/1 Year 23°C ± 5°
J	-150 to +760°C	0.001°C	1.0°C
K	-150 to +1372°C	0.001°C	1.0°C
N	-100 to +1300°C	0.001°C	1.0°C
T	-100 to +400°C	0.001°C	1.0°C
E	-150 to +1000°C	0.001°C	1.0°C
R	+400 to +1768°C	0.1°C	1.8°C
S	+400 to +1768°C	0.1°C	1.8°C
B	+1100 to +1820°C	0.1°C	1.8°C

DC SPECIFICATIONS

3724 CARD/3706A MULTIMETER UNCERTAINTY SPECIFICATIONS:

Function	Range	Notes
Voltage	All	Add 4.5 μV to PPM "of range"
Resistance	100 kΩ	Add 8 PPM to "of reading"
Resistance	1 MΩ	Add 80 PPM to "of reading"
Resistance	10 MΩ	Add 250 PPM to "of reading"
Resistance	100 MΩ	Add 5000 PPM to "of reading"
Resistance 2-wire	1 kΩ through 100 MΩ	Add 1.2 Ω (with REL) to PPM "of range" Add 64Ω (without REL) to PPM "of range"
Resistance 4-wire and Dry Circuit	1 Ω, 10 Ω, and 100 Ω	Ranges Not Available (maximum lead resistance exceeded, see manual for measurement considerations)

CONDITIONS: 1 PLC or 5 PLC.

ACCURACY: ±(ppm of reading + ppm of range) (ppm = parts per million; e.g., 10ppm = 0.001%).

GENERAL

ACTUATION TIME: <0.2ms.

TEMPERATURE ACCURACY USING AUTOMATIC CJC WITH 3724-ST ACCESSORY: 1°C for J, K, T, and E type (see mainframe specification for details).

RELAY TYPE: Optically isolated FET.

RELAY DRIVE SCHEME: Direct.

INTERLOCK: Backplane relays disabled when interlock connection removed.

RELAY DRIVE CURRENT: 4mA.

OPERATING ENVIRONMENT: Specified for 0°C to 50°C. Specified to 70% R.H. at 35°C.

STORAGE ENVIRONMENT: -25°C to 65°C.

WEIGHT: 1.13 kg (2.5 lbs.).

SAFETY: Conforms to European Union Directive 73/23/EEC, EN61010-1.

EMC: Conforms to European Union Directive 2004/108/EC, EN61326-1.

TYPICAL SCANNING SPEEDS, SWITCH ONLY¹:

Sequential scanning, single channel, immediate trigger advance: >1250 ch/s.

TYPICAL SCANNING SPEEDS, WITH MEASUREMENTS INTO MEMORY²:

DCV (10V range) or 2WΩ (1kΩ range): >1000 ch/s.

Thermocouple: >1000 ch/s.

3- or 4-Wire RTD: >450 ch/s.

4-Wire Ω (1kΩ range): >450 ch/s.

ACV (10V, 400Hz range): >1000 ch/s.

POWER BUDGET INFORMATION:

Quiescent Power (mW): 1150.

Channel Relay Power (mW) Each: 20.

Backplane Relay Power Consumption (mW) Each: 100.

See Chapter 8 of the Series 3700A user's manual for more detailed information.

NOTES

- Scanning script local to mainframe, within same bank, break before make.
- 3706A mainframe with autorange off, limits off, dmm.autodelay=0, dmm.autozero=0, 4½ digits (NPLC=.006), for ACV dmm.detectorbandwidth=300, for OHMS dmm.offsetcompensation=off, dmm.opendetector=off. Scanning script local to mainframe, sequential scan within same bank (2 pole) or card (4 pole), and break before make switching.

1.888.KEITHLEY (U.S. only)

www.keithley.com

KEITHLEY

A GREATER MEASURE OF CONFIDENCE

3730

6×16, High Density, Matrix Card

96 two-pole crosspoints with column expansion relays

- 6 row by 16 column matrix (2-pole)
- Analog backplane connection relays provide easy column expansion
- 300V, 1A switched or 2A carry signal capacity; 60W, 125VA
- Screw terminal connections provided on removable 3730-ST accessory
- 2μV and 100pA offsets
- Relay closures stored in onboard memory
- Latching electromechanical relays

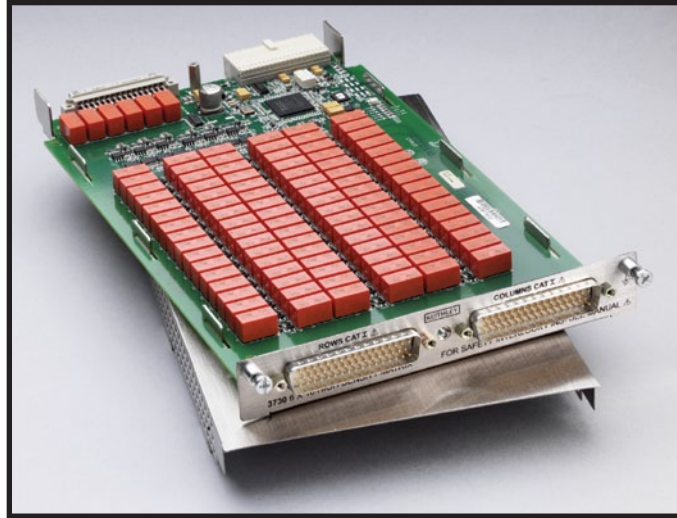

The Model 3730 is a two-pole, 6 row by 16 column matrix card. It can connect up to six differential instrument channels to any combination of 16 DUTs (devices under test). Any row can be connected to the Series 3700A mainframe backplane by using the analog backplane connection relays. This allows for easy matrix column expansion. A matrix of up to 6 rows by 96 columns can be supported within a single Model 3706A mainframe (with six Model 3730 cards).

The Model 3730 uses two 50-pin male D-sub connectors for signal connections. For screw terminal connections, use the detachable Model 3730-ST accessory.

ACCESSORIES AVAILABLE

3721-MTC-1.5	50 Pin D-sub Female to Male Cable, 1.5m (5 ft.)
3721-MTC-3	50 Pin D-sub Female to Male Cable, 3m (10 ft.)
3730-ST	Screw Terminal Block
3790-KIT50-R	50 Pin Female D-sub Connector Kit (contains 2 female D-sub connectors and 100 solder-cup contacts)

SERVICES AVAILABLE

3730-3Y-EW-STD	1-year factory warranty extended to 3 years from date of shipment
3730-5Y-EW-STD	1-year factory warranty extended to 5 years from date of shipment
C/3730-3Y-STD	3 (Z540-1 compliant) calibrations within 3 years of purchase*

*Not available in all countries

Ordering Information

3730 **6×16, High Density,
Matrix Card**

High density 6×16 matrix card

SWITCHING AND CONTROL

1.888.KEITHLEY (U.S. only)

www.keithley.com

KEITHLEY

A GREATER MEASURE OF CONFIDENCE

3730

6×16, High Density, Matrix Card

96 two-pole crosspoints with column expansion relays

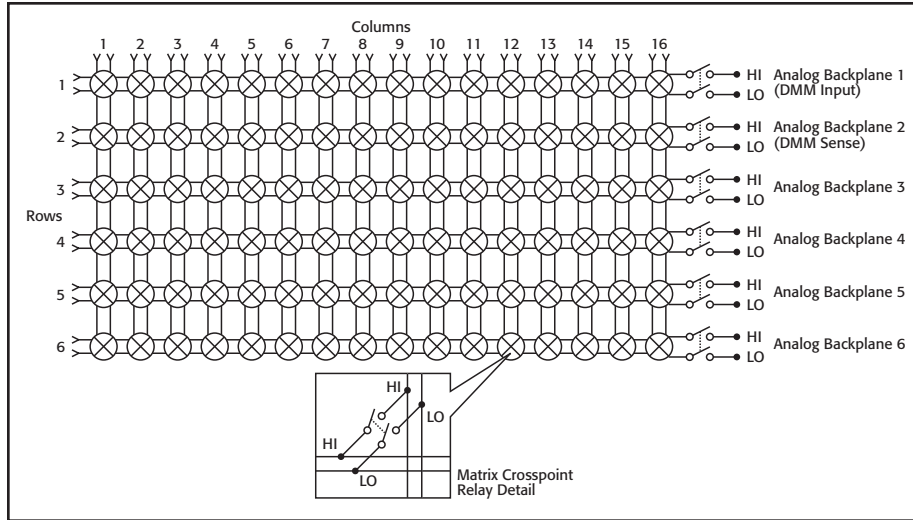

MATRIX CONFIGURATION: 6 row by 16 column matrix. Columns can be expanded using the backplane or isolated by relays.

CONTACT CONFIGURATION: 2 pole form A.
CONNECTOR TYPE: Two 50 pin male D-shells.

MODEL 3730-ST SCREW TERMINAL OPTION: #22 AWG typical wire size with 0.062 inch O.D. 88 conductors maximum. #16 AWG maximum wire size with 0.092 inch O.D. 44 conductor per card maximum.

MAXIMUM SIGNAL LEVEL: 300V DC or RMS, 1A switched (2A carry), 60W, 125VA.

COMMON MODE VOLTAGE: 300V DC or RMS between any terminal and chassis.

VOLT-HERTZ LIMIT: 8×10^7 .

CONTACT LIFE: $>10^5$ operations @ maximum signal level. $>10^8$ operations no load.¹

	$6 \times 16^{2,3}$
Channel Resistance (end of contact life)	<1.0 Ω
Contact Potential (differential)	< $\pm 2 \mu V$
Offset Current	< $\pm 100 \text{ pA}$
Isolation	
Differential	$10^{10} \Omega$, 250 pF
Channel-channel	$10^{10} \Omega$, 75 pF
Common Mode	$10^{10} \Omega$, 150 pF
Crosstalk Channel-channel	
300kHz	<-65 dB
1MHz	<-55 dB
20MHz	<-30 dB
Bandwidth	27 MHz

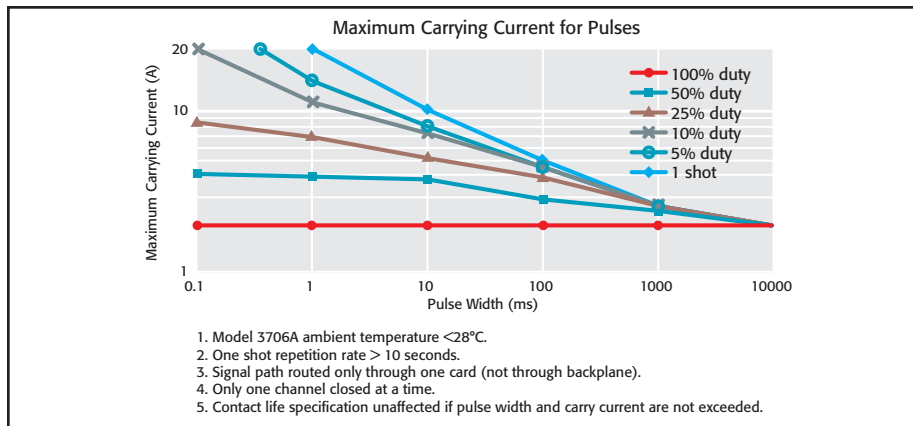

GENERAL

ACTUATION TIME: 4ms.
RELAY TYPE: Latching electromechanical.
RELAY DRIVE SCHEME: Hybrid Matrix.
INTERLOCK: Backplane relays disabled when terminal assembly is removed.
OPERATING ENVIRONMENT: Specified for 0° to 50°C . Specified to 70% R.H. at 35°C .
STORAGE ENVIRONMENT: -25° to 65°C .
WEIGHT: 2.5 lbs.
SAFETY: Conforms to European Union Directive 73/23/EEC, EN61010-1.
EMC: Conforms to European Union Directive 2004/108/EC, EN61326-1.

NOTES

- Minimum signal level 10mV, 10 μ A.
- Connections made using 3730-ST accessory.
- 3706A mainframe with all DMM backplane relays disconnected.

1.888.KEITHLEY (U.S. only)

www.keithley.com

KEITHLEY

A GREATER MEASURE OF CONFIDENCE

3731

- 6 row by 16 column matrix (2-pole) using high speed, long life reed relays
- Analog backplane connection relays provide easy column expansion
- 200V, 1A switched or 2A carry signal capacity; 10W, 10VA
- Screw terminal connections provided on removable 3731-ST accessory
- Relay actuation time of 0.5ms
- Ideal for multi-channel I-V testing with Series 2600A System SourceMeter® Instruments
- Long life dry reed relays (>10⁹ operations)

Ordering Information

3731 **6×16 High Speed, Reed Relay, Matrix Card**

6×16 High Speed, Reed Relay, Matrix Card

96 two-pole crosspoints with column expansion relays

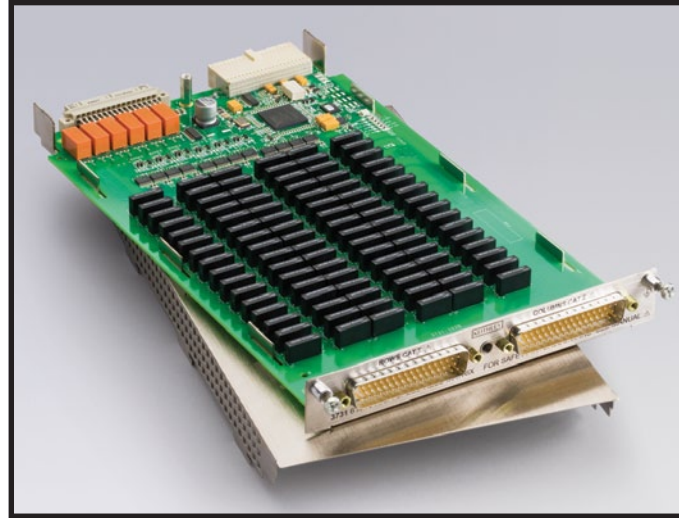

The Model 3731 is a two-pole, 6 row by 16 column reed relay matrix card. By using high speed reed relays with actuation times of 0.5ms, this card meets the requirements of demanding throughput applications while offering users the additional benefit of long life, exceeding one billion operations. The card can connect up to six differential instrument channels to any combination of 16 DUTs (devices under test). Any row can be connected to the Series 3700A mainframe backplane by using the analog backplane connection relays. This allows for easy matrix column expansion. A matrix of up to 6 rows by 96 columns can be supported within a single 3706A mainframe (with six Model 3731 cards).

The Model 3731 uses two 50-pin male D-sub connectors for signal connections. For screw terminal connections, use the detachable Model 3731-ST accessory.

ACCESSORIES AVAILABLE

3721-MTC-1.5	50-pin D-sub Female to Male Cable, 1.5m (5 ft.)
3721-MTC-3	50-pin D-sub Female to Male Cable, 3m (10 ft.)
3731-ST	Screw Terminal Block
3790-KIT50-R	50-pin Female D-sub Connector Kit (contains 2 female D-sub connectors and 100 solder-cup contacts)

SERVICES AVAILABLE

3731-3Y-EW-STD	1-year factory warranty extended to 3 years from date of shipment
3731-5Y-EW-STD	1-year factory warranty extended to 5 years from date of shipment
C/3731-3Y-STD	3 (Z540-1 compliant) calibrations within 3 years of purchase*

*Not available in all countries

3731

6×16 High Speed, Reed Relay, Matrix Card 96 two-pole crosspoints with column expansion relays

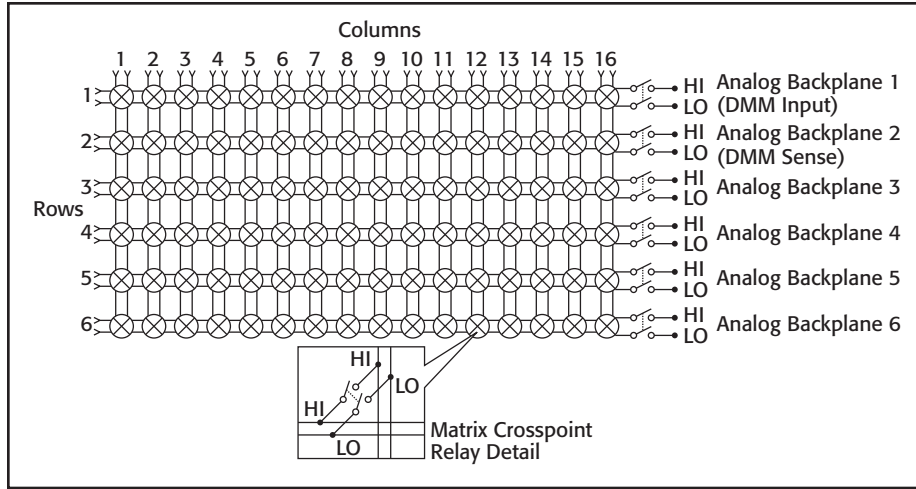

96 Two-Pole Crosspoints with Column Expansion Relays

MATRIX CONFIGURATION: 6 row by 16 column matrix. Columns can be expanded using the backplane or isolated by relays.

CONTACT CONFIGURATION: 2-pole form A.

CONNECTOR TYPE: Two 50-pin male D-shells.

MODEL 3731-ST SCREW TERMINAL OPTION:

Typical wire size: #22 AWG with .062 inch O.D.;

88 conductors maximum

Maximum wire size: #16 AWG with .092 inch O.D.;

44 conductors per card maximum.

MAXIMUM SIGNAL LEVEL: 200V DC or peak AC, 1A switched (2A carry), 10W, 10VA.

COMMON MODE VOLTAGE: 200V DC or peak AC between any signal path to a signal path or ground.

VOLT-HERTZ LIMIT: 8×10^7 .

CONTACT LIFE:

Reed: $>10^9$ operations no load. $>8 \times 10^6$ operations @ 100V, 10mA.

EMR (Backplane): $>10^8$ operations @ 5V, 10mA and 10^5 operations @ maximum signal level.

6×16^{1,2}

Channel Resistance (end of contact life)	<1.5 Ω
Contact Potential (differential)	< $\pm 80 \mu V$
Offset Current	< ± 500 pA
Isolation	
Differential	$3 \times 10^9 \Omega$, 300 pF
Channel-channel	$3 \times 10^9 \Omega$, 100 pF
Common Mode	$3 \times 10^9 \Omega$, 150 pF
Crosstalk Channel-channel	
300kHz	<-60 dB
1MHz	<-50 dB
15MHz	<-20 dB
Bandwidth	19 MHz

GENERAL

ACTUATION TIME: 0.5ms.

RELAY TYPE: Reed.

RELAY DRIVE SCHEME: Direct drive.

INTERLOCK: Backplane relays disabled when terminal assembly is removed.

OPERATING ENVIRONMENT: Specified for 0° to 50°C. Specified to 70% R.H. at 35°C.

STORAGE ENVIRONMENT: -25° to 65°C.

WEIGHT: 2.2 lbs.

SAFETY: Compliant with European Union Low Voltage Directive

EMC: Compliant with European Union EMC Directive 2004/108/EC, EN61326-1.

NOTES

1. Connections made using 3731-ST.

2. 3706A mainframe with all DMM backplane relays disconnected.

3732

Quad 4×28, Ultra-High Density, Reed Relay Matrix Card

448 one-pole crosspoints with bank configuration and backplane connection relays

- Four independent banks of 4×28 single pole matrices
- 200V, 1.2A carry or 0.75A switched signal capacity; 15W, 15VA
- Bank configuration relays enable alternative matrix sizes, including:
 - Dual 4×56 (1 wire)
 - Single 4×112 (1 wire)
 - Single 4×56 (2 wire)
- Optional accessory, Model 3732-ST-R, enables screw terminal access and additional matrix sizes including:
 - Dual 8×28 (1 wire)
 - Single 16×28 (1 wire)
 - Single 8×28 (2 wire)
- Analog backplane connection relays provide easy card-to-card column expansion
- Long life dry reed relays (>10⁹ operations)
- Ideal for high channel count I-V testing with Series 2600A System SourceMeter® Instruments

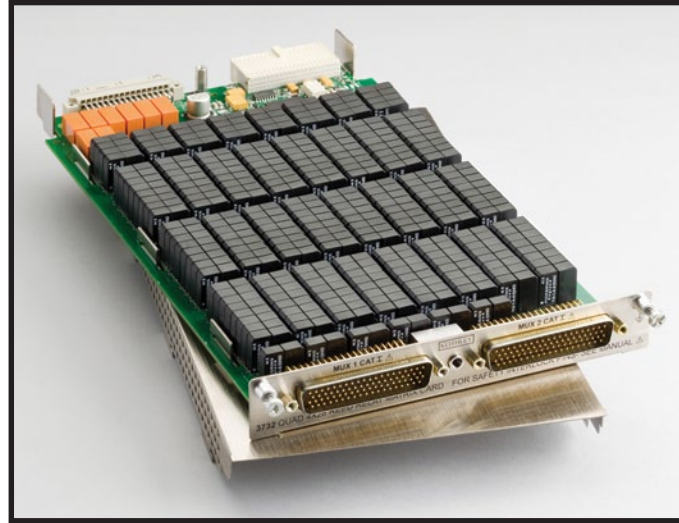

The ultra-high density Model 3732 matrix card is comprised of four banks, each with 4 rows by 28 columns of reed relays. This provides 448 single-pole crosspoints for maximum connection versatility in high channel count applications. For even greater flexibility, bank configuration relays are mounted on the card. They offer an automated method of connecting banks to enable two additional matrix configurations: single 4×112 and dual 4×56. This feature allows the matrix size to be easily adapted to existing or future applications. For differential (2-wire) measurements, a two-pole mode can be selected that enables automatic pairing of crosspoints to create a dual 4×28 or single 4×56 configuration. For larger matrix sizes, analog backplane relays are provided that enable rows to connect to the Series 3700A mainframe backplane. This allows, for example, a matrix of up to 4 rows by 672 columns within a single 3706A mainframe using six Model 3732 cards.

The card uses optimized reed relays that offer both low contact potential and low current offset to minimize the switching errors that often accompany this relay technology. Additionally, these relays provide greater signal voltage (200V) and current (1.2A carry) dynamic range while supporting the long life and fast actuation times necessary in many automated test applications.

The Model 3732 uses two 78-pin male D-sub connectors for signal and configuration connections. For screw terminal connections, two accessories are offered. Use the 3732-ST-R for the 16×28 or dual 8×28 matrix configurations. Use the 3732-ST-C for the 4×112, dual 4×56, or base quad 4×28 matrix configurations.

Ordering Information

3732 Quad 4×28, Ultra-High Density, Reed Relay Matrix Card

ACCESSORIES AVAILABLE

3732-ST-C	Screw Terminal Block for matrix configurations: Quad 4×28 (1 wire) Dual 4×28 (2 wire) Single 4×56 (2 wire) Dual 4×56 (1 wire) Single 4×112 (1 wire)
3732-ST-R	Screw Terminal Block for matrix configurations: Dual 8×28 (1 wire) Single 8×28 (2 wire) Single 16×28 (1 wire)
3732-MTC-1.5	78-pin, D-sub Female-to-Male Cable, 1.5m (5 ft.)
3732-MTC-3	78-pin, D-sub Female-to-Male Cable, 3m (10 ft.)
3791-CIT	Contact Insertion and Extraction Tool
3791-KIT78-R	78-pin, Female D-sub Connector Kit (contains 2 female D-sub connectors and 156 solder-cup contacts)

SERVICES AVAILABLE

3732-3Y-EW-STD	1-year factory warranty extended to 3 years from date of shipment
3732-5Y-EW-STD	1-year factory warranty extended to 5 years from date of shipment
C/3732-3Y-STD	3 (Z540-1 compliant) calibrations within 3 years of purchase*
*Not available in all countries	

Quad 4×28, ultra-high density, reed relay matrix card

SWITCHING AND CONTROL

Quad 4x28, Ultra-High Density, Reed Relay Matrix Card

448 one-pole crosspoints with bank configuration and backplane connection relays

Quad 4x28 (1-wire) or Dual 4x28 (2-wire) Matrix Configuration

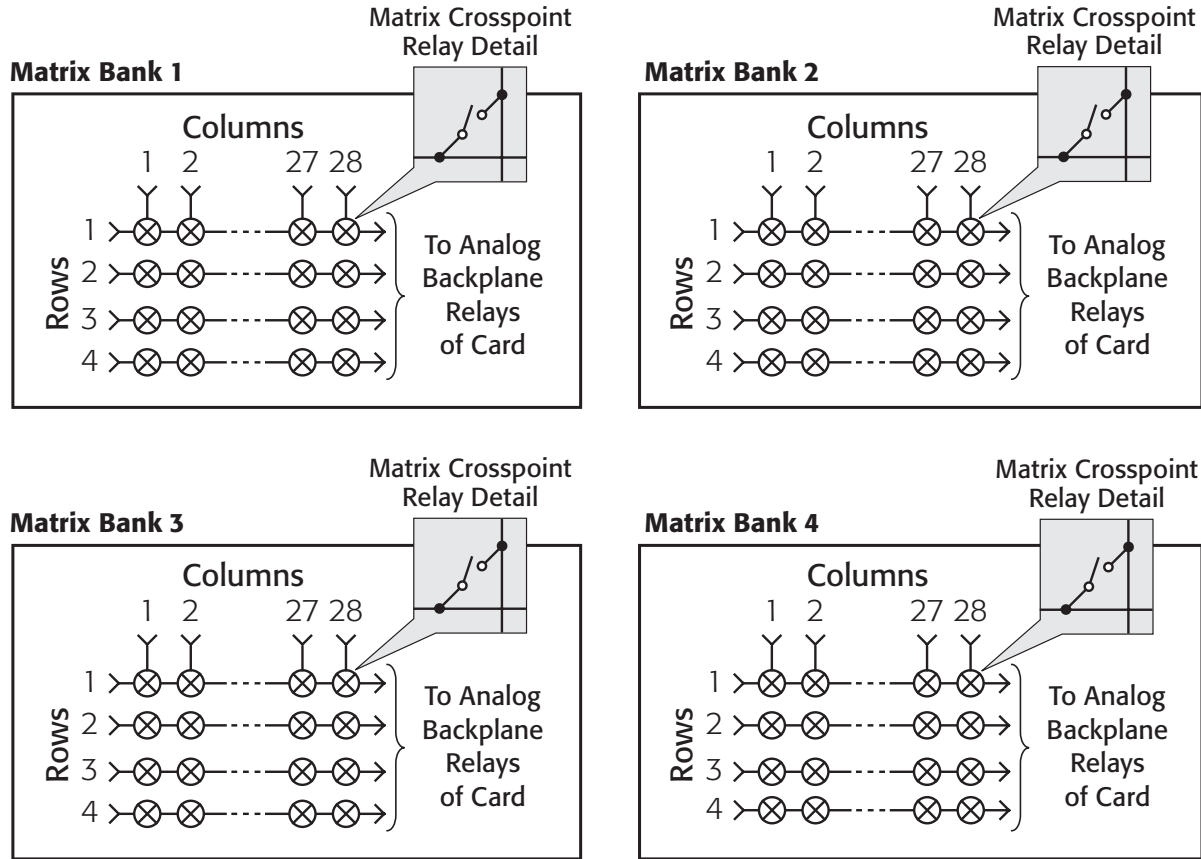

Analog Backplane Connection Relays

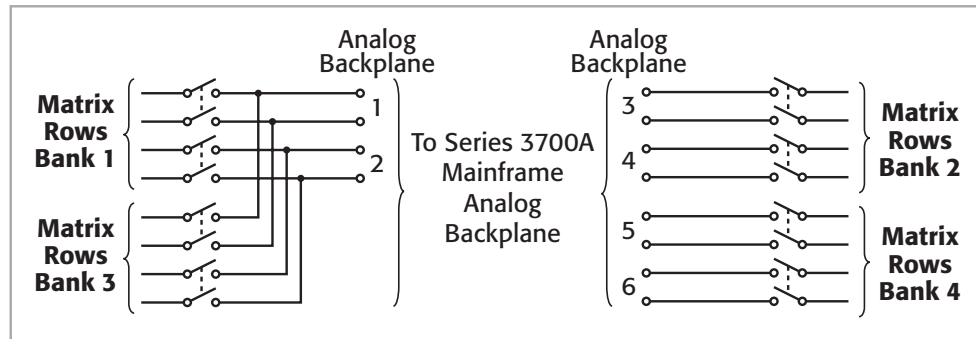

3732

Quad 4x28, Ultra-High Density, Reed Relay Matrix Card

448 one-pole crosspoints with bank configuration and backplane connection relays

Additional Matrix Configurations Using Bank Configuration Relays

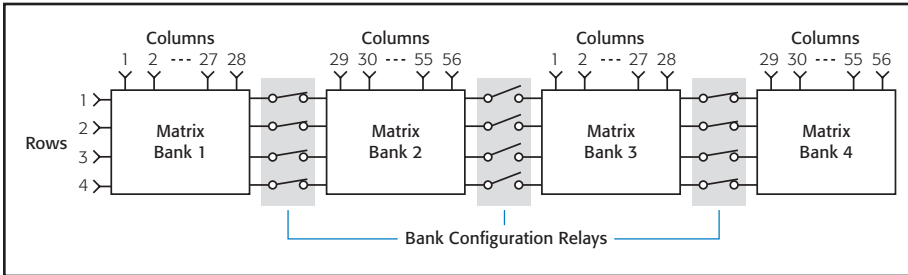

Dual 4x56 (1-wire) or single 4x56 (2-wire) matrix configuration using bank configuration relays

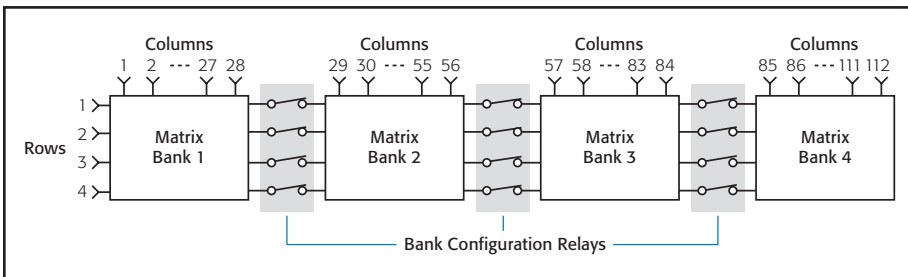

Single 4x112 (1-wire) matrix configuration using bank configuration relays

Additional Matrix Configurations Using the Model 3732-ST-R Screw Terminal Block

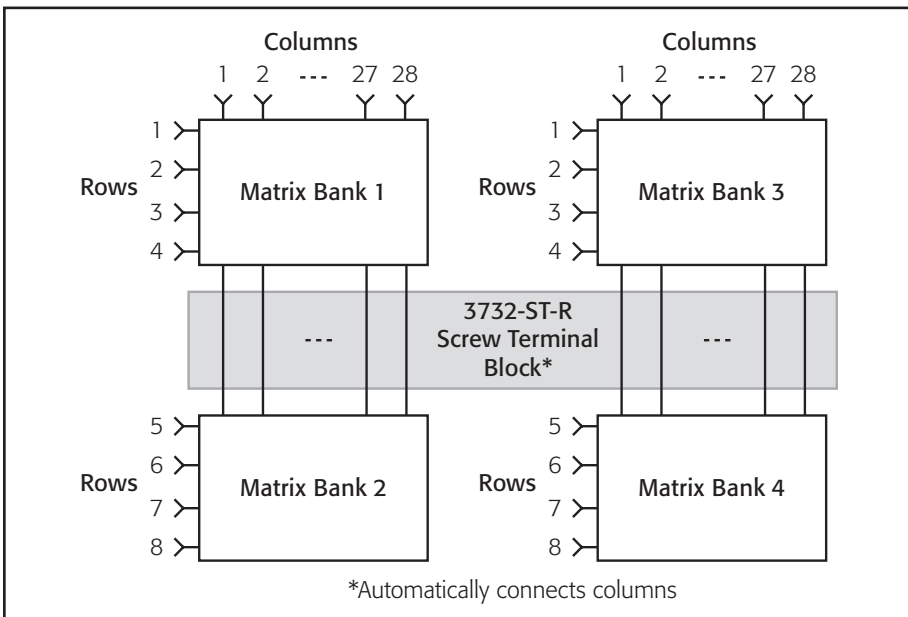

Dual 8x28 (1-wire) or single 8x28 (2-wire) matrix configuration using one Model 3732-ST-R screw terminal block

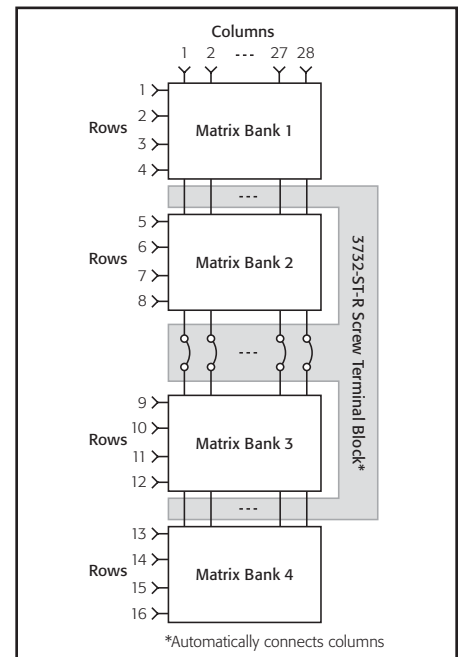

Single 16x28 (1-wire) matrix configuration using one Model 3732-ST-R screw terminal block

3732

Quad 4×28, Ultra-High Density, Reed Relay Matrix Card

448 one-pole crosspoints with bank configuration and backplane connection relays

MATRIX CONFIGURATION: Four banks, each with 4 rows by 28 columns of reed relays. Bank configuration and analog backplane relays are included for additional matrix configurations. Banks can be connected together via relays creating dual 4×56 matrices or a single 4×112 matrix. Row expansion is available using optional screw terminal accessories.

CONTACT CONFIGURATION: Single-pole form A.

CONNECTOR TYPE: Two 78-pin male D-shells.

MODEL 3732-ST-R SCREW TERMINAL OPTION: Provides terminal block access and column jumper blocks for extended row configurations including Dual 8×28 (1W), Single 8×28 (2W), and Single 16×28 (1W).

Typical Wire Size: #22 AWG with 0.062 inch O.D.; 88 conductors per card maximum.

Maximum Wire Size: #16 AWG with 0.092 inch O.D.; 44 conductors per card maximum.

MODEL 3732-ST-C SCREW TERMINAL OPTION: Provides terminal block access for Quad 4×28 (1W), Dual 4×28 (2W), Dual 4×56 (1W), Single 4×56 (2W), and Single 4×112 (1W) matrix configurations.

Typical Wire Size: #22 AWG with 0.062 inch O.D.; 88 conductors per card maximum.

Maximum Wire Size: #16 AWG with 0.092 inch O.D.; 44 conductors per card maximum.

MAXIMUM SIGNAL LEVEL: 200VDC or peak AC, 0.75A switched (1.2A carry), 15W/15VA max. switch power.

COMMON MODE VOLTAGE: 200VDC or peak AC between any signal path to a signal path or ground.

VOLT-HERTZ LIMIT: 8×10⁷.

CONTACT LIFE: Reed: >10⁹ operations no load, >8×10⁶ operations @ 100V, 10mA.

EMR (Backplane): >10⁸ operations @ 5V, 10mA and 10⁵ operations at maximum signal level.

MODEL 3732 PARAMETERS

Parameter	Quad 4×28 ^{1,2}	Dual 4×56 ^{1,2}	Single 4×112 ^{1,2}	Dual 8×28 ^{2,3}	Single 16×28 ^{2,3}
Channel Resistance (end of life)	<1.5 Ω	<2.0 Ω	<2.5 Ω	<1.6 Ω	<2.0 Ω
Contact Potential (differential)	<±10 μV	<±20 μV	N/A	<±15 μV	N/A
Contact Potential (single ended)	<±20 μV	<±40 μV	<±65 μV	<±20 μV	<±20 μV
Offset Current	<±0.5 nA	<±1.0 nA	<±2.0 nA	<±1.0 nA	<±2.0 nA
Isolation					
CH-CH	3×10 ⁹ Ω/150 pF	1.5×10 ⁹ Ω/300 pF	7.5×10 ⁸ Ω/600 pF	2×10 ⁹ Ω/200 pF	1.5×10 ⁹ Ω/300 pF
Common mode	1.5×10 ⁹ Ω/300 pF	1.5×10 ⁹ Ω/300 pF	7.5×10 ⁸ Ω/600 pF	2×10 ⁹ Ω/200 pF	1.5×10 ⁹ Ω/300 pF
Crosstalk Ch-Ch					
300 kHz	<-37 dB	<-37 dB	<-37 dB	<-37 dB	<-37 dB
1 MHz	<-26 dB	<-26 dB	<-26 dB	<-26 dB	<-26 dB
15 MHz	<-7 dB	<-7 dB	<-7 dB	<-7 dB	<-7 dB
Bandwidth	15 MHz	15 MHz	10 MHz	15 MHz	15 MHz

1. Connections made using Model 3732-ST-C.
2. Model 3706A mainframe with all DMM backplane relays disconnected.
3. Connections made using Model 3732-ST-R.

GENERAL

POWER BUDGET INFORMATION:

Quiescent Power Usage:

Mode	Quiescent Power
Quad 4×28	780 mW
Dual 4×56	916 mW
Single 4×112	984 mW
Dual 8×28	780 mW
Single 16×28	780 mW

Channel Relay Power Consumption (each): 17mW.

Backplane Relay Power Consumption (each): 100mW.

For additional power-budgeting information, refer to the Series 3700A Module Schematics and Connections section in the Series 3700A User's Manual (part no. 3700S-900-01).
ACTUATION TIME: 0.6ms.

RELAY TYPE: Reed (signal relays); EMR (backplane relays)

RELAY DRIVE SCHEME: Direct drive.

RELAY DRIVE CURRENT: 3.2mA.

INTERLOCK: Backplane relays disabled when terminal assembly interlock signal removed. When asserted allows system to read and save ID configuration bits.

EMC: Compliant with European Union EMC Directive.

SAFETY: Compliant with European Union Low Voltage Directive.

OPERATING ENVIRONMENT: Specified for 0° to 50°C. Specified to 70% relative humidity at 35°C.

STORAGE ENVIRONMENT: -25° to 65°C.

WEIGHT: 3.40 lbs (1.54kg).

1.888.KEITHLEY (U.S. only)

www.keithley.com

KEITHLEY

A GREATER MEASURE OF CONFIDENCE

3740

32-channel Isolated Switch Card

28 Form C relays and 4 high power Form A relays

- 28 general purpose Form C relays rated for 300V, 2A switched or 3A carry signal capacity; 60W, 125VA
- 4 high current Form A relays rated for 250VAC, 7A or 30VDC, 7A switched capacity; 210W
- Analog backplane connection relays provided for user interconnections
- Screw terminal connections provided on removable 3740-ST accessory
- Relay closures stored in onboard memory
- Latching electromechanical relays

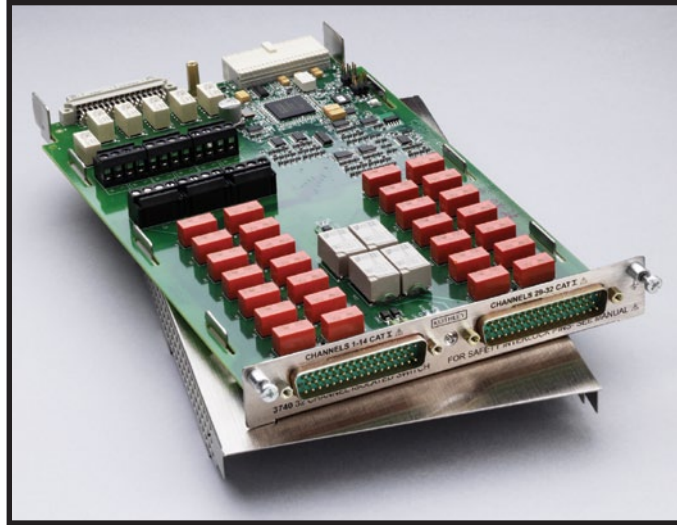

The Model 3740 offers 28 general-purpose form C channels that are ideal for routing power or other control devices. For higher power applications of up to 7A, four additional high current form A channels are provided.

If any general purpose signal requires routing to the Series 3700A mainframe backplane, terminal blocks are located on the card, which are enabled with jumpers. Custom configurations can be created with the user accessible terminal blocks. For additional protection, an onboard temperature sensor will notify the mainframe when the card's operating temperature exceeds 70°C, compromising system specifications.

The Model 3740 uses two 50-pin male D-sub connectors for signal connections. For screw terminal connections, use the detachable Model 3740-ST accessory.

ACCESSORIES AVAILABLE

3721-MTC-1.5	50-pin D-sub Female to Male Cable, 1.5m (5 ft.)
3721-MTC-3	50-pin D-sub Female to Male Cable, 3m (10 ft.)
3740-ST	Screw Terminal Block
3790-KIT50-R	50-pin Female D-sub Connector Kit (contains 2 female D-sub connectors and 100 solder cup contacts)

SERVICES AVAILABLE

3740-3Y-EW-STD	1-year factory warranty extended to 3 years from date of shipment
3740-5Y-EW-STD	1-year factory warranty extended to 5 years from date of shipment
C/3740-3Y-STD	3 (Z540-1 compliant) calibrations within 3 years of purchase*

*Not available in all countries

Ordering Information

3740 General Purpose Card with 32 Independent Channels

1.888.KEITHLEY (U.S. only)

www.keithley.com

KEITHLEY

A GREATER MEASURE OF CONFIDENCE

3740

32-channel Isolated Switch Card

28 Form C relays and 4 high power Form A relays

Model 3740 specifications

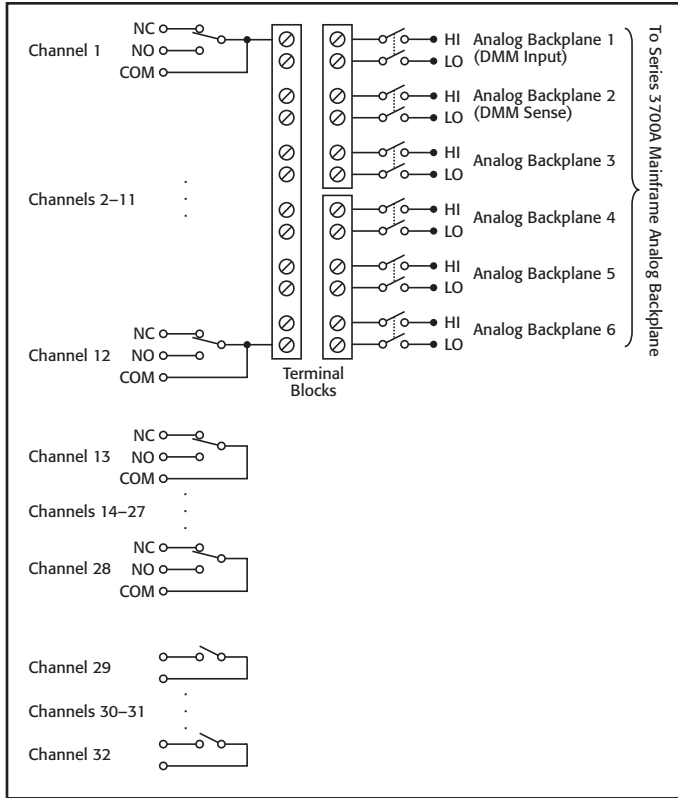

RELAY SWITCH CONFIGURATION: 32 general purpose independent channels. 28 channels of Form C switching at 2A and 4 channels of Form A switching at 7A. Relays can be connected to each other and backplane via removable terminal blocks.

CONTACT CONFIGURATION: **General Purpose:** 1 pole Form C. **High Current:** 1 pole Form A. **CONNECTOR TYPE:** Two 50 pin male D-shells.

MODEL 3740-ST SCREW TERMINAL OPTION: #22 AWG typical wire size with 0.062 inch O.D. 84 conductors maximum. #16 AWG maximum wire size with 0.092 inch O.D. 44 conductors per card maximum.

MAXIMUM SIGNAL LEVEL: **Form C:** 300V DC or RMS, 2A switched (3A carry), 60W, 125VA. **Form A:** 250VAC 7A, 30VDC 7A, 210W.

COMMON MODE VOLTAGE: 300V DC or RMS between any terminal and chassis.

VOLT-HERTZ LIMIT: 8×10⁷.

CONTACT LIFE: **Form C:** >10⁵ operations at maximum signal level, >10⁸ operations no load.¹ **Form A:** >10⁵ operations at maximum signal level, >5×10⁷ operations no load.¹

CHANNEL RESISTANCE (end of contact life): <0.5Ω

CONTACT POTENTIAL: <±3μV typical per contact.

ISOLATION: **Channel-channel:** 10⁹Ω, <200pF. **Common Mode:** >10¹⁰Ω, <150pF.

Crosstalk (Channel-channel, 50Ω load–50Ω source): **100kHz:** <–50dB. **1MHz:** <–35dB. **10MHz:** <–15dB.

BANDWIDTH: 30MHz.

GENERAL

OVER-TEMPERATURE: Temperature sensor indicates over temperature.

ACTUATION TIME: **Form C:** 4ms. **Form A:** 10ms.

RELAY TYPE: **Form C:** Latching electromechanical. **Form A:** Nonlatching electromechanical.

RELAY DRIVE SCHEME: Direct.

INTERLOCK: Backplane relays disabled when interlock connection is removed.

OPERATING ENVIRONMENT: Specified for 0° to 50°C. Specified to 70% R.H. at 35°C.

STORAGE ENVIRONMENT: –25° to 65°C.

WEIGHT: 2.5 lbs.

SAFETY: Conforms to European Union Directive 73/23/EEC, EN61010-1.

EMC: Conforms to European Union Directive 2004/108/EC, EN61326-1.

NOTES

1. Minimum signal level 10mV, 10μA.

SWITCHING AND CONTROL

1.888.KEITHLEY (U.S. only)

www.keithley.com

KEITHLEY

A GREATER MEASURE OF CONFIDENCE

3750

- 40 bidirectional digital input/output bits
- High current driver outputs for sinking (300mA)
- Internal 5V, 50mA logic supply for powering external logic circuits
- 2 isolated analog output channels, programmable to $\pm 12V$, 0–20mA, or 4–20mA
- 4 gated 32-bit counters with 1MHz input rate
- Screw terminal connections provided with removable 3750-ST accessory
- External supply voltage supported on digital I/O

Ordering Information

3750 **Multifunction Control Card**

ACCESSORIES AVAILABLE

3721-MTC-1.5	50-pin female-to-male D-sub Cable Assembly, 1.5m (4.9 ft)
3721-MTC-3	50-pin female-to-male D-sub Cable Assembly, 3m (9.8 ft)
3750-ST	Screw Terminal Block
3790-KIT50-R	50-pin female D-sub Connector Kit (contains 2 D-sub connectors and 100 solder cup contacts)

SERVICES AVAILABLE

3750-3Y-EW-STD	1-year factory warranty extended to 3 years from date of shipment
3750-5Y-EW-STD	1-year factory warranty extended to 5 years from date of shipment
C/3750-3Y-DATA	3 (Z540-1 compliant) calibrations within 3 years of purchase*

*Not available in all countries

1.888.KEITHLEY (U.S. only)

www.keithley.com

Multifunction Control Card

40 digital I/O bits, 2 analog output channels, and 4 counters



Use the Model 3750 to monitor and control your automated test system. The flexibility and speed provided by the 40 digital I/O bits, four counters, and two analog outputs make it well-suited for a wide variety of system control applications.

Digital I/O

The Model 3750 offers 40 digital I/O bits arranged in five banks. Each bank is comprised of eight bits each, and each bank can be programmed as either input or output. Digital I/O is often used to control processes and monitor the status of switches, contacts, and other control points. Additional features include scanning capabilities, such as writing a unique output pattern or reading banks of inputs at rates up to 1000 rdgs/second. Also, pattern matching is available, making it ideal for complex event algorithms.

Further versatility is provided by supporting external voltage levels of up to 30V and output current sink levels of 300mA for control of external devices like RF/microwave relays.

Analog Outputs

The two analog outputs of the Model 3750 are designed for general purpose applications such as setpoint control or as bias supplies to your device under test. For maximum utility, these outputs are programmable as voltage ($\pm 12V$) or current (0–20mA or 4–20mA). A number of protection features are provided, including monitoring for current and/or voltage compliance and the ability to disconnect automatically during fault conditions. Output relays are supplied for each channel, ensuring mechanical isolation between your control device and the analog output.

Counters

Four 32-bit counters are provided with a maximum input rate of 1MHz. Each counter has a gate input that offers precise control of event counting and totalizing for a broad range of system components, such as: fixtures, limit switches, pass/fail indicators, revolutions, or time-related quantities. The counters, like the digital I/O, can be used in scanning operations and pattern matching as well as supporting reading rates of up to 1000 rdgs/second.

Self-calibration

When your Model 3706A mainframe is equipped with the high performance multimeter option, hardware and software is provided for self-calibration of analog outputs (voltage and current) and counter thresholds.

KEITHLEY

A GREATER MEASURE OF CONFIDENCE

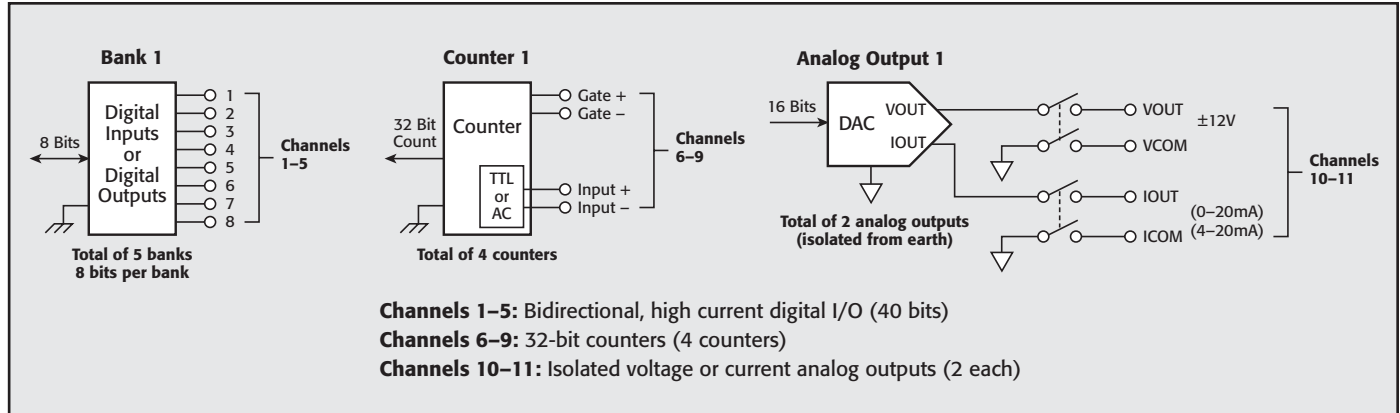

Figure 1. Block diagram

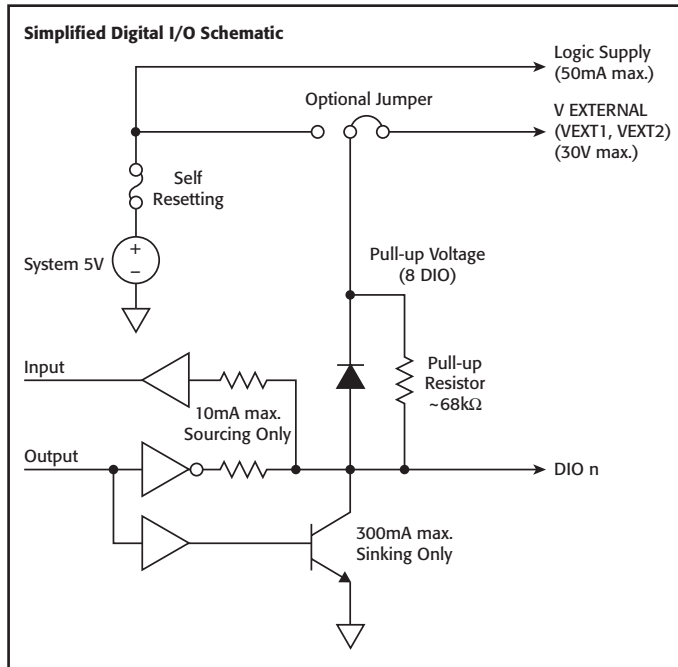

Figure 2. Simplified I/O schematic

Specifications

DIGITAL I/O¹

CONFIGURATION: 40 bidirectional digital I/O bits arranged in 5 banks of 8 bits each.

Each bank can be configured for either input or output capability. 1 bank of I/O is equivalent to 1 system channel.

DIGITAL INPUT SPECIFICATIONS

An internal weak pull-up resistor of approximately 68kΩ is provided on the card for each I/O. This pull-up resistor can be removed via onboard jumper on a channel (8 bit) basis. The pull-up voltage can either connect to the internally supplied 5V or an externally supplied voltage of up to 30V via onboard jumper. An internal 5V supply connection is separately available to run external logic circuits.

DIGITAL INPUT LOGIC LOW VOLTAGE: 0.8V max.

DIGITAL INPUT LOGIC HIGH VOLTAGE: 2V min.

DIGITAL INPUT LOGIC LOW CURRENT: -600μA max @ 0V.

DIGITAL INPUT LOGIC HIGH CURRENT: 50μA max @ 5V.

LOGIC: Positive true.

SYSTEM INPUT MINIMUM READ SPEED²: 1000 readings/second.

MAXIMUM EXTERNALLY SUPPLIED PULL-UP VOLTAGE: 30V.

MAXIMUM EXTERNALLY SUPPLIED VOLTAGE TO ANY DIGITAL I/O LINE: Pull-up voltage (5V internal or up to 30V external).

DIGITAL OUTPUT SPECIFICATIONS

Each output has an internal fly-back diode for driving inductive loads. Each output is protected against continuous short circuits and over temperature. An internal 5V supply connection is separately available to run external logic circuits.

DIGITAL OUTPUT LOGIC HIGH VOLTAGE: 2.4V minimum @ I_{out} = 10mA, sourcing only.

DIGITAL OUTPUT LOGIC LOW VOLTAGE: 0.5V maximum @ I_{out} = -300mA, sinking only.

MAXIMUM OUTPUT SINK CURRENT: 300mA per output, 3.0A total per card.

LOGIC: Positive true.

SYSTEM OUTPUT MINIMUM WRITE SPEED³: 1000 readings/second.

MAXIMUM EXTERNALLY SUPPLIED VOLTAGE TO ANY DIGITAL I/O LINE: Pull-up voltage (5V internal or up to 30V external).

ALARM: Trigger generation is supported for a maskable pattern match or state change on any of channels 1 through 5.

PROTECTION: Optional disconnect (set to inputs) during output fault conditions.

INTERNAL 5V LOGIC SUPPLY: The internal logic supply is designed for powering external logic circuits of up to 50mA maximum. The logic supply is internally protected with a self-resetting fuse. Fuse reset time < 1 hour.

NOTES

- All channels power up configured as inputs.
- All channels configured as inputs.
- All channels configured as outputs.

COUNTER/TOTALIZER INPUT

MAXIMUM COUNT: $2^{32} - 1$.
MAXIMUM INPUT RATE: 1MHz, rising or falling edge, programmable.
MINIMUM INPUT PULSE WIDTH: 500ns.
INPUT SIGNAL LEVEL: 200mV p-p (minimum), 42V peak (maximum).
THRESHOLD: AC (0V) or TTL logic level.
GATE INPUT: TTL-HI (Gate+), TTL-LO (Gate-) or NONE.
MINIMUM GATE INPUT SETUP TIME: 1 μ s.
COUNT RESET: Manual or Read + Reset.
SYSTEM INPUT MINIMUM READ SPEED: 1000 readings/second.
ALARM: Trigger generation is supported for a count match or counter overflow on any of channels 6 through 9.

ANALOG VOLTAGE OUTPUT

The isolated analog voltage output is designed for general purpose, low power applications.
OUTPUT AMPLITUDE: ± 12 V up to 10mA.
OVERLOAD CURRENT: 21mA minimum.
RESOLUTION: 1mV.
FULL SCALE SETTling TIME: 1ms to 0.1% of output.
DC ACCURACY: \pm (% of output + mV):
 1 Year 23° $\pm 5^{\circ}$ C: 0.15% + 16mV.
 90 Day 23° $\pm 5^{\circ}$ C: 0.1% + 16mV.
 24 Hour 23° $\pm 5^{\circ}$ C: 0.04% + 16mV.
TEMPERATURE COEFFICIENT: \pm (0.02% + 1.2mV)/ $^{\circ}$ C.
10mV MAXIMUM UPDATE RATE: 350 μ s to 1% accuracy. System limited.
OUTPUT FAULT DETECTION: System fault detection is available for short circuit output/current compliance.
ISOLATION: 300V peak channel to channel or channel to chassis.
PROTECTION: Optional disconnect during output fault conditions.
MINIMUM GUARANTEED STABLE CAPACITIVE LOAD: 10nF.

NOTES

- Programming up to 1% over full scale range is supported.
- Measured with standard load shown in Figure 3.
- Measured with >10M Ω input DMM (DCV, filter, 1 PLC rate). Warm-up time is 1 hour @ 10mA load with 3750-ST.

ANALOG CURRENT OUTPUT

The isolated analog current output is designed for 0–20mA or 4–20mA unipolar modes of operation.
OUTPUT AMPLITUDE: 0 to 20mA or 4 to 20mA.
COMPLIANCE VOLTAGE: 11V minimum.
MAXIMUM OPEN CIRCUIT VOLTAGE: 16V.
RESOLUTION: 1 μ A.
FULL SCALE SETTling TIME: 1ms to 0.1% of output.
DC ACCURACY: \pm (% of output + μ A):
 1 Year 23° $\pm 5^{\circ}$ C: 0.15% + 18 μ A.
 90 Day 23° $\pm 5^{\circ}$ C: 0.1% + 18 μ A.
 24 Hour 23° $\pm 5^{\circ}$ C: 0.04% + 18 μ A.
TEMPERATURE COEFFICIENT: \pm (0.02% + 1.6 μ A)/ $^{\circ}$ C.
OUTPUT FAULT DETECTION: System fault detection is available for open circuit output/voltage compliance.
ISOLATION: 300V peak channel to channel or channel to chassis.
PROTECTION: Optional disconnect during output fault conditions.

NOTES

- Measured with standard load shown in Figure 3.
- Measured with <2 Ω shunt DMM (DCI, filter, 1 PLC rate). Warm-up time is 1 hour with 3750-ST.

GENERAL

CONNECTOR TYPE: Two 50-pin male D-shells.
OPERATING ENVIRONMENT: Specified for 0 $^{\circ}$ C to 50 $^{\circ}$ C. Specified to 70% R.H. at 35 $^{\circ}$ C.
STORAGE ENVIRONMENT: –25 $^{\circ}$ C to 65 $^{\circ}$ C.
WEIGHT: 1.27kg (2.80 lbs.).
SAFETY: Conforms to European Union Directive 73/23/EEC, EN61010-1.
EMC: Conforms to European Union Directive 2004/108/EC, EN61326-1.
POWER BUDGET INFORMATION:
Quiescent Power: 3300mW.
Digital Outputs Each Channel (1 through 5): 325mW.
Analog Channel Each (10 and 11): 820mW.
Totalizer Channel All (6 through 9): 730mW.
 Analog channels and counter channels may optionally be turned off to conserve system power.
 See Chapter 8 of the Series 3700A user's manual for more detailed information.

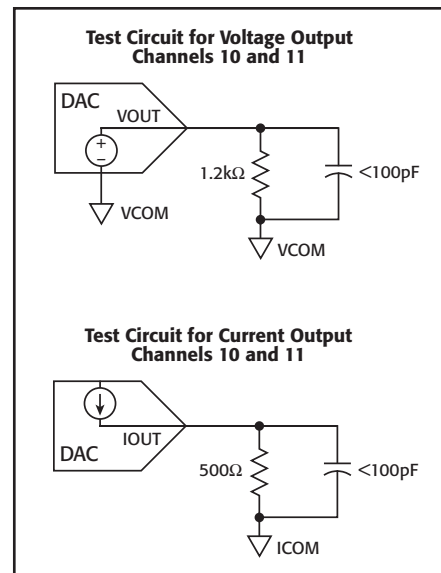

Figure 3. Standard load test circuits

7001

Switch/Control Mainframe

80-channel



- DC, RF, and optical switch capability
- Supports industry's broadest range of signals
- Integrates easily with DMM and SourceMeter® instruments
- Full channel status display
- 2 card slots
- Supports more than 30 switch/control cards

Ordering Information

7001 80-channel Switch/
Control Mainframe

required, reducing the amount of switching hardware needed. Higher density also provides extra capacity and flexibility.

Analog backplane. The 7001's analog backplane is used by the high density switch cards. The backplane eliminates intercard wiring and increases configuration flexibility. Two cards can be connected through the backplane to create a 1×80 multiplexer, a 4×20 matrix, or a multiplexer/matrix combination that provides matrix row expansion.

Channel status display. See the status of every channel simultaneously. The vacuum fluorescent display of the 7001 shows the open/close status of each channel in the mainframe simultaneously. The graphical display pattern makes it much easier to configure a test system, make modifications, or debug an existing program. The status of the cards in both slots is displayed side by side on the same screen.

Easy to set up and use. The 7001 has a number of built-in features that make it easy to set up, run, change, or modify. It conforms to IEEE-488.2 and SCPI (Standard Commands for Programmable Instruments). All aspects of the instrument can be programmed from the front panel and over the IEEE bus.

Trigger Link. Trigger Link is a high speed trigger bus that provides simple trigger coordination between the Model 7001 and other instruments. This bus eliminates GPIB communication delays during scanning to increase overall system throughput dramatically.

More than 30 cards available. The 7001 switch cards accommodate a broad range of signals, maintain very high accuracy, and will not degrade signal quality. By minimizing signal errors, these cards will prevent degradation due to offset voltage, isolation resistance, and leakage current.

With its broad range of available cards, the 7001 provides multi-pole switching. Cards such as the 7011 can be used in either 2- or 4-pole configuration. If a card does not have the pole capacity required, the 7001 can still accommodate the application—just select the CARD PAIR function. It allows the channel closures in both slots to be synchronized for up to 8-pole switching.

Matrix cards are displayed in row-column format. Only the available rows and columns of the card are displayed. Rows are horizontal and columns are vertical.

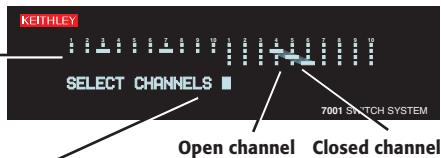

Matrix crosspoints are entered in row-column format. The first number selects the card, the second is the row, and the third number is the column.



Multiplexer card display. The first row across represents channels 1 to 10. The second row is channels 11 to 20. Only the available channels are displayed.

Scan in any order. A scan does not have to be a contiguous set of channels. Scan forward, backward, or skip channels.

Display indicates scanning. As a scan sequence is executed, the display updates to show the scanning action.

ACCESSORIES AVAILABLE

COMMUNICATION INTERFACES AND CABLES

7007-1	Double Shielded, Premium GPIB Cable, 1m
7007-2	Double Shielded, Premium GPIB Cable, 2m
KPCI-488LPA	IEEE-488 Interface/Controller for the PCI Bus
KUSB-488B	IEEE-488 USB-to-GPIB Interface Adapter

RACK MOUNT KITS

4288-1	Single Fixed Rack Mount Kit
4288-2	Dual Fixed Rack Mount Kit

TRIGGERING

8501-1	Trigger Link Cable, DIN-to-DIN, 1m
8501-2	Trigger Link Cable, DIN-to-DIN, 2m
8502	Trigger Link to BNC Break-out Box
8503	Trigger Link Cable, DIN-to-dual BNC, 1m
8505	Male to 2-Female Y-DIN Cable for Trigger Link

SERVICES AVAILABLE

7001-3Y-EW	1-year factory warranty extended to 3 years from date of shipment
------------	---

1.888.KEITHLEY (U.S. only)

www.keithley.com

KEITHLEY

A GREATER MEASURE OF CONFIDENCE

7001

Switch/Control Mainframe

80-channel

System

CAPACITY: 2 plug-in cards per mainframe.

MEMORY: Battery backed-up storage for 100 switch patterns.

SWITCH SETTling TIME: Automatically selected by the mainframe for each card. Additional time from 0 to 99999999 seconds can be added in 1ms increments.

TRIGGER SOURCES:

- External Trigger (TTL-compatible, programmable edge, 600ns minimum pulse, rear panel BNC).
- IEEE-488 bus (GET, *TRG)
- Trigger Link
- Manual (front panel)
- Internal Timer, programmable from 1ms to 99999999 seconds in 1ms increments.

STATUS OUTPUT: Channel Ready (TTL-compatible signal, rear panel BNC). Low going pulse (10 μ s typical) issued after relay settling time. For two different switch cards, 7001 will be set to the slowest relay settling time.

SWITCHING SEQUENCE: Automatic break-before-make.

MAINFRAME DIGITAL I/O: 4 open-collector outputs (30V maximum pull-up voltage, 100mA maximum sink current, 10 Ω output impedance), 1 TTL compatible input, 1 common.

RELAY DRIVE: 700mA maximum for both card slots.

CARD SIZE: 32mm high \times 114mm wide \times 272mm long (1 $\frac{1}{4}$ in \times 4 $\frac{1}{2}$ in \times 10 $\frac{3}{4}$ in).

CARD COMPATIBILITY: Fully compatible with all 7XXX cards.

Throughput

EXECUTION SPEED OF SCAN LIST¹:

	7011 Card	7015 Card
Individual Channels:	130/second	500/second
Memory Setups:	125/second	450/second

TRIGGER EXECUTION TIME (maximum time from activation of Trigger Source to start of switch open or close²):

Source	Latency	Jitter
GET ³	200 μ s	<50 μ s
*TRG ³	5.0 ms	
Trigger Link	200 μ s	<13 μ s
External	200 μ s	<13 μ s

NOTES

- Rates include switch settling time of cards: 3ms for 7011 and 500 μ s for 7015 cards.
- Excluding switch settling time.
- Assuming no IEEE-488 commands are pending execution.

IEEE-488 Command Execution Time

Command	Execution Time ¹	
	Display Off	Display On
OPEN (@!1)	7.5 ms	8.5 ms
CLOS (@!1)	7.5 ms	8.5 ms
MEM:REC M1	5.0 ms	6.0 ms

NOTES

- Measured from the time at which the command terminator is taken from the bus to the time at which the relay begins to open or close.

Analog Backplane

SIGNALS: Four 3-pole rows (Hi, Lo, Guard). These signals provide matrix and multiplexer expansion between cards within one mainframe.

MAXIMUM VOLTAGE: 250V DC, 250V rms, 350V AC peak, signal path to signal path or signal path to chassis.

MAXIMUM CURRENT: 1A peak.

PATH ISOLATION:

- >10¹⁰ Ω , <50pF path to path (any Hi, Lo, Guard to another Hi, Lo, Guard).
- >10¹⁰ Ω , <50pF differential (Hi to Lo or Hi, Lo to Guard).
- >10¹⁰ Ω , <75pF path to chassis.

CHANNEL CROSSTALK: <-65dB @ 1MHz (50 Ω load).

BANDWIDTH: <3dB loss at 100MHz (50 Ω load).

IEEE-488 BUS IMPLEMENTATION

STANDARDS CONFORMANCE: Conforms to SCPI-1990, IEEE-488.2, and IEEE-488.1.

MULTILINE COMMANDS: DCL, LLO, SDC, GET, GTL, UNT, UNL, SPE, SPD.

UNLINE COMMANDS: IFC, REN, EOJ, SRQ, ATN.

INTERFACE FUNCTIONS: SH1, AH1,T5, TE0, L4, LE0, SRI, RLI, PPO, DC1, DT1, CO, EI.

GENERAL

DISPLAY: Dual-line vacuum fluorescent.

- 1st line:20-character alphanumeric.
- 2nd line:32-character alphanumeric.

REAR PANEL CONNECTORS: IEEE-488

- 8-pin micro-DIN connector for digital I/O
- 8-pin micro-DIN for Trigger Link
- 8-pin micro-DIN for Trigger Link expansion
- BNC for External Trigger
- BNC for Channel Ready

POWER: 100V to 240Vrms, 50/60Hz, 50VA maximum.

EMC: Conforms to European Union Directive 89/336/EEC, EN61326-1.

SAFETY: Conforms to European Union Directive 73/23/EEC, EN61010-1.

EMI/RFI: Meets VDE 0871B and FCC Class B.

ENVIRONMENT:

- Operating: 0°–50°C, <80% relative humidity (0°–35°C).
- Storage: –25° to +65°C.

DIMENSIONS, WEIGHT: 89mm high \times 216mm wide \times 375mm deep (3 $\frac{1}{2}$ in \times 8 $\frac{1}{2}$ in \times 14 $\frac{3}{4}$ in). Net weight 3.4kg (7 $\frac{1}{2}$ lbs).

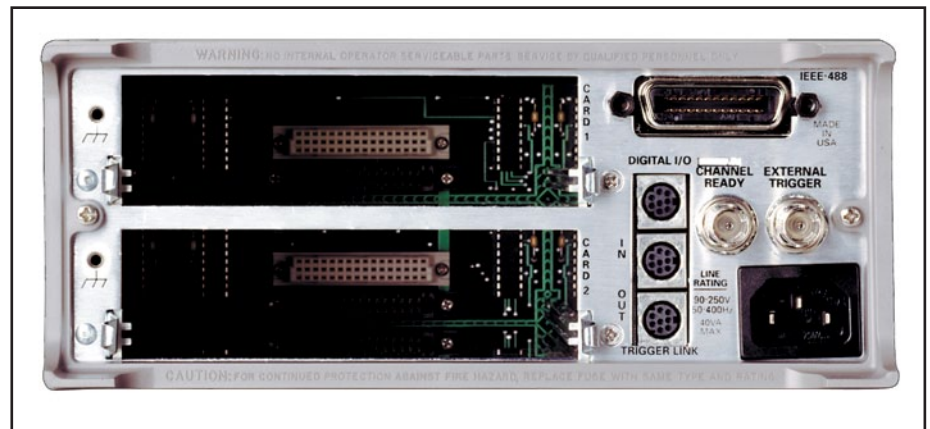

Model 7001 rear panel

7002

Switch/Control Mainframe

400-channel



- DC, RF, and optical switch capability
- Interactive channel status display
- Optional light pen for front panel programming
- Integrates easily with DMM and SourceMeter® instruments
- Full channel status display
- 10 card slots
- Supports more than 30 switch/control cards

Ordering Information

**7002 400-channel Switch/
Control Mainframe**

ACCESSORIES AVAILABLE

COMMUNICATION INTERFACES AND CABLES

7007-1	Double Shielded, Premium GPIB Cable, 1m
7007-2	Double Shielded, Premium GPIB Cable, 2m
7078-PEN	Programming Light Pen (includes holder)
KPCI-488LPA	IEEE-488 Interface/Controller for the PCI Bus
KUSB-488B	IEEE-488 USB-to-GPIB Interface Adapter

RACK MOUNT KITS

7002-RMK-1	Fixed Rack Mount Kit
7002-RMK-2	Slide Rack Mount Kit

TRIGGERING

8501-1	Trigger Link Cable, DIN-to-DIN, 1m
8501-2	Trigger Link Cable, DIN-to-DIN, 2m
8502	Trigger Link to BNC Break-out Box
8503	Trigger Link Cable, DIN-to-dual BNC, 1m
8505	Male to 2 Female Y-DIN Cable for Trigger Link

SERVICES AVAILABLE

7002-3Y-EW	1-year factory warranty extended to 3 years from date of shipment
------------	---

1.888.KEITHLEY (U.S. only)**www.keithley.com****KEITHLEY**

A GREATER MEASURE OF CONFIDENCE

The Model 7002 Switch System is a 10-slot mainframe that supports up to 400 2-pole multiplexer channels or 400 matrix crosspoints. The front panel includes a unique interactive display of channel status for quick programming. Scanning speeds of up to 300 channels per second are possible with the high density switch cards. The wide selection of more than 30 different switch cards makes the 7002 one of the most flexible switching mainframes available.

Reduce the Size and Cost of Your Switching Application.

Up to 400 channels of 2-pole switching. A single Model 7002 mainframe can accommodate up to ten 40-channel cards. That's 400 channels in a

single full-rack package that is only 178mm high (7 in). This level of density provides some important advantages. First, it reduces the amount of switching hardware required for a given application. Second, it provides high flexibility. The high density cards can be used with the special signal cards to cover all your signal needs for a large application with one mainframe.

Switch a wide range of signals. The 7002 is fully compatible with all 7001 switch cards. From this broad selection of more than 30 cards, you can assemble a switch configuration that will ensure signal integrity and minimize errors. These cards allow the 7002 to switch DC signals from femtoamps to amps, nanovolts to kilovolts, as well as RF and optical signals.

Analog backplane. The analog backplane used by the high density cards adds configuration flexibility and eliminates intercard wiring. For example, the outputs of a multiplexer card can be connected to the row inputs of a matrix card. Or, the outputs of ten multiplexer cards can be connected to form one large 1×400 multiplexer. Intercard wiring is eliminated by using the analog backplane to form these configurations.

Faster Test Development

Unique channel status display. The interactive front panel display helps shorten the time required to configure the 7002 and develop test software. The display indicates the open/close status of each channel in the mainframe. This information is very useful when programming the 7002 and developing application software. Knowing the channel status also helps to verify proper operation during the debug phase.

Light pen programming. An optional light pen provides point and click programming from the front panel. By selecting the desired channels or range of channels, the scan list can be built, matrix patterns created, channels opened or closed, and patterns stored in memory. The 7002's non-volatile memory stores up to 500 complete switch patterns.

Automatic card configuration. When the high density cards are installed, the 7002 automatically configures each slot independently for the proper card. The channel status display on the front panel adjusts to show each card's capacity and configuration.

Front panel Info key. At the touch of a button, the operator receives context-sensitive, on-line information to help configure the system. This information is displayed on a 52-character alphanumeric display for clear and readable messages. There is no need to refer constantly to the operator's manual. All information messages, operating instructions, and prompts are available in English, German, and French. Just select the desired language in the configuration menu.

Programmable channel closure restrictions. The 7002 allows specific channels to be locked out from closure. This restriction can be conditional based on the open/close state of other channels or crosspoints. This capability is useful to prevent certain signals from being accidentally connected to high power circuits, for example.

7002

Switch/Control Mainframe

400-channel

System Throughput

300 channel per second scanning. The 7002 can scan through up to 300 channels per second. This scan process can be controlled by the internal time base of the 7002 or through external triggers. The scan sequence is controlled by what appears in the scan list. The scan list can include channels, ranges of channels, and memory locations. This approach gives maximum flexibility while obtaining maximum throughput.

Built-in Scan Control and Trigger Link. The built-in scan control eliminates the need for the computer to control every step of the test procedure. Simply program the 7002 to control the channel spacing, scan spacing, and number of scans. Trigger Link gives you access to six independent hardware trigger lines on a single cable.

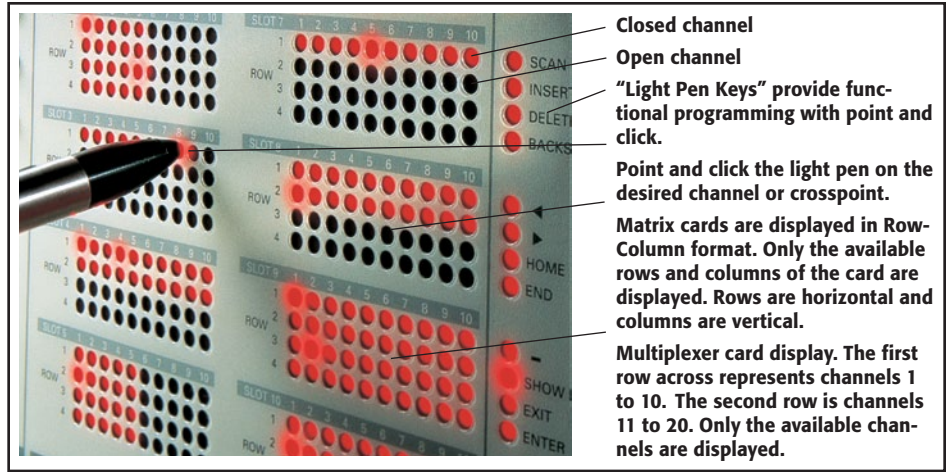

SYSTEM

CAPACITY: 10 plug-in cards per mainframe.

MEMORY: Battery backed-up storage for 500 switch patterns.

SWITCH SETTling TIME: Automatically selected by the mainframe. For different switchcards, 7002 will be set to the slowest relay settling time. Additional time from 0 to 99999.999 seconds can be added in 1ms increments.

TRIGGER SOURCES:

External Trigger (TTL-compatible, programmable edge, 600ns minimum pulse, rear panel BNC).

IEEE-488 bus (GET, *TRG)

Trigger Link

Manual (front panel)

Internal Timer, programmable from 1.0ms to 99999.999 seconds in 1.0ms increments.

STATUS OUTPUT: Channel Ready (TTL-compatible signal, rear panel BNC). Low going pulse (10μs typical) issued after relay settling time.

SWITCHING SEQUENCE: Break-before-make (programmable).

MAINFRAME DIGITAL I/O: Four open collector outputs (30V maximum, 100mA maximum sink current, 10Ω output impedance), one TTL compatible input, one common, one +5V.

RELAY DRIVE: 3.5A maximum for all 10 card slots.

CARD SIZE: 32mm high × 114mm wide × 272mm long (1¼ in × 4½ in × 10¾ in).

CARD COMPATIBILITY: Fully compatible with all 7001 cards.

ANALOG BACKPLANE

SIGNALS: Four 3-pole rows (Hi, Lo, Guard). These signals provide matrix and multiplexer expansion between cards within one mainframe.

MAXIMUM VOLTAGE: 250V DC, 250V rms, 350V AC peak, signal path to signal path or signal path to chassis.

MAXIMUM CURRENT: 1A peak.

PATH ISOLATION:

>10¹⁰Ω, <50pF path to path (any Hi, Lo, Guard to another Hi, Lo, Guard)

>10¹⁰Ω, <50pF differential (Hi to Lo or Hi, Lo to Guard).

>10¹⁰Ω, <75pF path to chassis.

CHANNEL CROSSTALK: <-65dB @ 1MHz (50Ω load).

BANDWIDTH: <3dB loss at 100MHz (50Ω load).

THROUGHPUT

EXECUTION SPEED OF SCAN LIST (channels or memory locations per second):

	Channels	Memories
Break-Before-Make	OFF 300	243
	ON 270	189

TRIGGER EXECUTION TIME (maximum time from activation of Trigger Source to start of switch open or close²):

Source	Latency	Jitter
GET1	200 μs	<15 μs
*TRG2, 3	3.0 ms	
Trigger Link	200 μs	<10 μs
External	200 μs	<10 μs
Timer		<25 μs

NOTES

1. Excluding switch settling time.
2. Assuming no IEEE-488 commands are pending execution.
3. Display off.

IEEE-488 COMMAND EXECUTION TIME

Command	Execution Time ¹
CLOS (@!1)	<8 ms + Relay Settle Time
OPEN (@!1)	<8 ms + Relay Settle Time
MEM:REC M1	<9 ms + 2× Relay Settle Time (BBM ON)
	<9 ms + Relay Settle Time (BBM OFF)

NOTES

1. Measured from the time at which the command terminator is taken from the bus to relay energize. With display OFF.

IEEE-488 BUS IMPLEMENTATION

STANDARDS CONFORMANCE: Conforms to SCPI-1990, IEEE-488.2, and IEEE-488.1.

MULTILINE COMMANDS: DCL, LLO, SDC, GET, GTL, UNT, UNL, SPE, SPD.

UNILINE COMMANDS: IFC, REN, EOI, SRQ, ATN.

INTERFACE FUNCTIONS: SH1, AH1, T5, TE0, L4, LE0, SRI, RLI, PPO, DCL1, DT1, C0, E1.

All aspects of 7002 operation are available from the front panel or over the IEEE-bus interface. The 7002 conforms to IEEE-488.2 and the SCPI (Standard Commands for Programmable Instruments) command language protocol.

- Scan List
- Scan Spacing
- Channel Spacing
- Number of Scans
- Number of Channels
- Trigger Source
- Single Channel Mode
- Channel Restrictions
- Save Mainframe Configuration Setups
- Digital I/O
- Card Pair
- Channel Delay
- Number of Poles
- Channel Pattern Memory

GENERAL

DISPLAY: Dual-line vacuum fluorescent. 1st line: 20-character alphanumeric. 2nd line: 32-character alphanumeric. Channel status LED grid.

LIGHT PEN OPTION: Provides interactive programming of channels, cross points, scan lists, and memory.

REAR PANEL CONNECTORS: IEEE-488; 9-pin DB9 Female; 8-pin micro DIN for Trigger Link; 8-pin micro DIN for Trigger Link expansion; BNC for External Trigger; BNC for Channel Ready

POWER: 100V to 240Vrms, 50/60Hz, 110VA maximum.

EMC: Complies with European Union Directive 89/336/EEC, EN61326-1.

SAFETY: Conforms to European Union Directive 73/23/EEC, EN61010-1).

EMI/RFI: Meets VDE 0871B and FCC Class B.

ENVIRONMENT: Operating: 0°C to 50°C, <80% RH (0°C to 35°C). Storage: -25°C to +65°C.

DIMENSIONS, WEIGHT: 178mm high × 438mm wide × 448mm deep (7 in × 17¼ in × 17½ in). Net weight 9.1kg (20 lb).

Selector Guide

Switch Cards for 7001, 7002

	No. of Channels	Card Config.	Contact Config.	Max. Voltage	Max. Current	Max. Power	Contact Potential	Max. Offset Current	Recomm. Frequency	Connection Type	CE	Comments
HIGH DENSITY												
7011-C	40	Multiplexer	2 form A	110V	1A	60VA	<1 μ V	<100pA	2MHz	Connector	Yes	Four independent 1 \times 10 multiplexers, connection to backplane
7011-S	40	Multiplexer	2 form A	110V	1A	60VA	<500nV	<100pA	2MHz	Screw term.	Yes	Four independent 1 \times 10 multiplexers, connection to backplane
7012-C	4 \times 10	Matrix	2 form A	110V	1A	60VA	<1 μ V	<100pA	2MHz	Connector	Yes	Rows connect to analog backplane
7012-S	4 \times 10	Matrix	2 form A	110V	1A	60VA	<500nV	<100pA	2MHz	Screw term.	Yes	Rows connect to analog backplane
7013-C	20	Isolated Switch	2 form A	110V	1A	60VA	<1 μ V	<100pA	10MHz	Connector	Yes	
7013-S	20	Isolated Switch	2 form A	110V	1A	60VA	<500nV	<100pA	10MHz	Screw term.	Yes	
7015-C	40	Multiplexer	2 form A	175V	34mA	0.3VA	<5 μ V	<1nA	500kHz	Connector	Yes	Solid state switch for high reliability
7015-S	40	Multiplexer	2 form A	175V	34mA	0.3VA	<5 μ V	<1nA	500kHz	Screw term.	Yes	Solid state switch for high reliability
7018-C	28	Multiplexer	3 form A	110V	1A	60VA	<5 μ V	<100pA	2MHz	Connector	Yes	3 pole switching
7018-S	28	Multiplexer	3 form A	110V	1A	60VA	<5 μ V	<100pA	2MHz	Screw term.	Yes	3 pole switching
7035	36	Multiplexer	2 form A	60V	1A	30VA	<1 μ V	<100pA	10MHz	Connector	Yes	9 independent 1 \times 4 multiplexers
7036	40	Isolated Switch	1 form A	60V	1A	30VA	<4 μ V	<100pA	10MHz	Connector	Yes	40 independent channels of 1-pole switching
7111-S	40	Multiplexer	1 form C	110V	1A	60VA	<500nV	<100pA	2MHz	Screw term.	Yes	Four independent 1 \times 10 multiplexers, connection to backplane

Control

7019-C	Dual 3 \times 6	Matrix	1 form A	200V	1A	10VA	<25 μ V	<100pA	2MHz	Connector	Yes	6-wire resistance measurements
7020	80	Digital I/O								Connector	Yes	40 inputs/40 outputs
7020-D*												
7021	30/20	Mux/Digital I/O	2 form A	110V	1A	30VA	<3 μ V	<100pA	10MHz	Connector	Yes	Dual multiplexers. Up to 30 channels, 10 digital inputs, 10 digital outputs.
7037-D*	30/20	Isolated/Digital I/O	1 form A	110V	1A	30VA	<4 μ V	<100pA	10MHz	Connector	Yes	30 independent channels of 1-pole switching, 10 digital inputs, 10 digital outputs
7065												See page 189 for details. Hall Effect measurement buffer card

RF

7016A	Double 1 \times 4	2 isolated switches	1 pole, 4 throw	30V	500mA	10VA	<6 μ V		2GHz	SMA	Yes	Optional 50 Ω termination
7017	Double 1 \times 4	2 isolated switches	1 pole, 4 throw	30V	1A	10VA	<25 μ V		800MHz	SMA	Yes	10 ⁸ closures contact life.
7038	12	Three 1 \times 4 multiplexers	1 pole, 1 of 4 tree	24V	10mA	10W @ 1.2GHz	<15 μ V		2GHz	75 Ω SMB	Yes	75 Ω unterminated receptacle

OPTICAL	No. of Channels	Fiber Type	Wavelength (nm)	Connector	Fiber Length
7090-8-4	1 \times 8	Multimode fiber 62.5/125	780–1350	FC/SPC	1 m
7090-16-6	1 \times 16	Single mode fiber (SMF-28) 9/125	1290–1650	FC/SPC	1 m

* Cards with a -D suffix feature D-sub connectors.

1.888.KEITHLEY (U.S. only)

www.keithley.com

KEITHLEY

A GREATER MEASURE OF CONFIDENCE

Selector Guide

Switch Cards for 7001, 7002

	No. of Channels	Card Config.	Contact Config.	Max. Voltage	Max. Current	Max. Power	Contact Potential	Max. Offset Current	Recomm. Frequency	Connection Type	CE	Comments
HIGH CURRENT												
7053	10	Multiplexer	2 form A	300V	5A	100VA	<1mV		1MHz	Screw term.		
HIGH VOLTAGE												
7154	10	Multiplexer	2 form A	1100V	500mA	10VA	<35 μ V		1MHz	Screw term.	Yes	
LOW CURRENT												
7152	4 \times 5	Matrix	2 form A	200V	500mA	10VA	<20 μ V	<1pA	60MHz	Connector	Yes	
7153	4 \times 5	Matrix	2 form A	1300V	500mA	10VA	<50 μ V	<1pA	60MHz	Connector	Yes	
7158	10	Multiplexer	1 form C	30V	100mA		<200 μ V	<1pA	1MHz	BNC	Yes	
LOW VOLTAGE												
7067	10	Multiplexer	4 form A	150V	350mA	10VA	<1 μ V		1MHz	Screw term.	Yes	4 wire resistance measurements
7168	8	Multiplexer	2 form A	10V	50mA		<30nV		1kHz	Screw term.	Yes	
THERMOCOUPLE												
7014	39	Multiplexer	2 form A	110V	1A	60VA	<1 μ V	<100pA	2MHz	Screw term.	Yes	Built-in cold junction ref.

Selector Guide

Switch Card Accessories

7001, 7002, 705, 706 Switch Card Accessories

	Cables			Connectors	Adapters	Tools
7011-C	7011-MTC-1	7011-MTC-2		7011-KIT-R		
7011-S				7011-ST		
7111-S						
7012-C	7011-MTC-1	7011-MTC-2		7011-KIT-R		
7012-S				7012-ST		
7013-C	7011-MTC-1	7011-MTC-2		7011-KIT-R		
7013-S				7013-ST		
7014	7401			7014-ST		
7015-C	7011-MTC-1	7011-MTC-2		7011-KIT-R		
7015-S				7015-ST		
7018-C	7011-MTC-1	7011-MTC-2		7011-KIT-R		
7018-S				7018-ST		
7019-C	7019-C-MTCL-2	7019-C-MTCL-2	7019-MTC-1	7011-KIT-R		
7020	7020-MTC-2			7011-KIT-R (incl.)		
7020-D				7020-DT		
7021	7011-MTC-1	7011-MTC-2		7011-KIT-R (incl.)		
7035	7035-MTC-2			7011-KIT-R (incl.)		
7036	7036-MTC-2			7011-KIT-R (incl.)		
7037-D				7037-DT		
7152	7152-MTC-2, -10	7152-TRX-10		7152-KIT 7152-MTR		7152-HCT 7074-HCT 7074-CIT
7153	7153-TRX					
7158	4801	4802-10	4803		4804	

7011-C, 7011-S, 7111-S

40-channel Multiplexer Cards Quad 1×10 Multiplexer Configuration

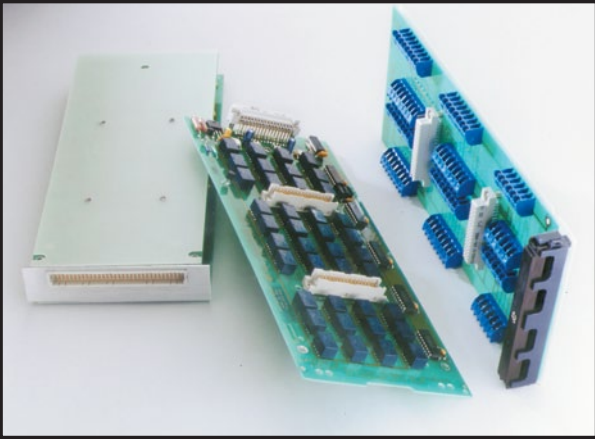

- Quad 1×10 multiplexer for 2-, 4-, or 8-pole operation
- Connects to 7001/7002 backplane for easy expandability
- 500nV, 100pA offsets

Ordering Information

7011-C	Quad 1×10 Multiplexer with 96-pin Mass Terminated Connector Board
7011-S	Quad 1×10 Multiplexer with Screw Terminal Connector Board
7111-S	Quad 1×10 Form C Multiplexer with Screw Terminal Connector Board

ACCESSORIES AVAILABLE

FOR 7011-C:

7011-KIT-R	96-pin Female Connector Kit
7011-MTC-1	96-pin Mass Terminated Cable, Female to Female, 1m
7011-MTC-2	96-pin Mass Terminated Cable, Female to Female, 2m

FOR 7011-S AND 7111-S:

7011-ST	Extra Screw Terminal Connection Board
---------	---------------------------------------

SERVICES AVAILABLE

7011-C-3Y-EW	1-year factory warranty extended to 3 years from date of shipment
7011-S-3Y-EW	1-year factory warranty extended to 3 years from date of shipment
7111-S-3Y-EW	1-year factory warranty extended to 3 years from date of shipment

The Model 7011 40-channel multiplexer has four independent banks of 1×10 switching. Each channel is 2-pole. These four banks can be combined for a wide variety of switching configurations—for example, dual 1×20, or 1×10 and 1×30, or one large 1×40. The 7001 mainframe can automatically configure the 7011 to switch 4-pole signals by combining channel pairs. This gives you a dual 1×10 4-pole multiplexer or a single 1×20 4-pole multiplexer.

Each of the four multiplexer outputs on this card connects to the 7001/7002 analog backplane through removable jumpers for even greater flexibility. Two 7011 cards can be used to make a single 1×80 multiplexer with all intercard connections through the backplane. The 7011 multiplexer outputs can also be connected to the rows of the 7012 via the backplane for row expansion.

The Model 7111-S is a form C version of the 7011-S. The 7111-S is a low-voltage, quad 1×10, single-pole form C multiplexer card. The 7111-S assembly consists of a screw terminal connector card and a relay card. External test circuits are wired directly to the screw terminals of the connector card.

These cards automatically configure the 7001 or 7002 mainframe. Two connection options are available, screw terminal for maximum flexibility or a single 96-pin quick disconnect connector.

MULTIPLEX CONFIGURATION: Four independent 1×10 2-pole multiplex banks or two independent 1×10 4-pole multiplex banks. Adjacent banks can be connected together. Jumpers can be removed to isolate any bank from the backplane.

CONTACT CONFIGURATION: 2-pole Form A (Hi, Lo) (1-pole form C for 7111-S).

CONNECTOR TYPE:

7011-C: 96-pin male DIN connector.

7011-S and 7111-S: Screw terminal, #16AWG maximum wire size, with 0.092 inch O.D. 28 conductors per card maximum. #22AWG typical wire size with 0.062 inch O.D. 88 conductors per card maximum.

MAXIMUM SIGNAL LEVEL:

DC Signals: 110V DC between any two pins, 1A switched, 30VA (resistive load).

AC Signals: 125V rms and 175V AC peak, between any two pins, 1A switched, 60VA (resistive load).

COMMON MODE VOLTAGE: 175V peak, any pin to chassis.

CONTACT LIFE: Cold Switching: 10⁸ closures. **At Maximum Signal Levels:** 10⁵ closures.

CHANNEL RESISTANCE (per conductor): <1Ω.

CONTACT POTENTIAL: 7011-C: <1μV per channel contact pair <3μV typical per single contact. 7011-S, 7111-S: <2μV per contact pair <5μV typical per single contact.

OFFSET CURRENT: <100pA.

ACTUATION TIME: 3ms.

ISOLATION:

Bank: >10°Ω, <25pF.

Channel to Channel: >10°Ω, <50pF.

Differential: Configured as 1×10:

>10°Ω, <100pF. Configured as 1×40:
>10°Ω, <200pF.

Common Mode: Configured as 1×10:

>10°Ω, <200pF. Configured as 1×40:
>10°Ω, <600pF.

CROSSTALK (1MHz, 50Ω Load): Bank: <-40dB. Channel: <-40dB.

INSERTION LOSS (50Ω Source, 50Ω Load): <0.1dB below 1MHz, <3dB below 2MHz.

RELAY DRIVE CURRENT (per relay):

7011-C, -S: 16mA

7111-S: 28mA

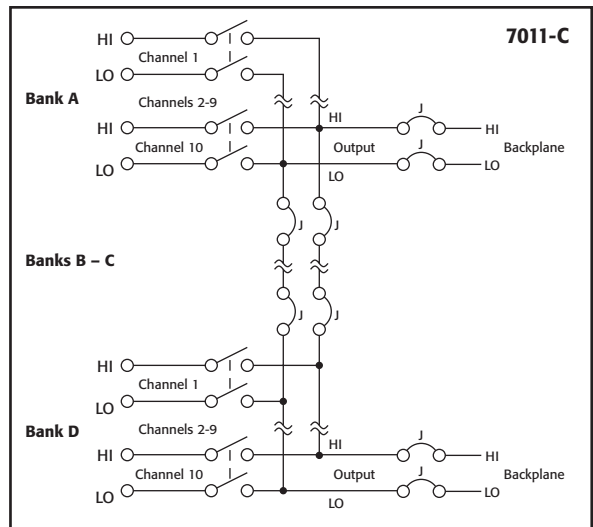

1.888.KEITHLEY (U.S. only)

www.keithley.com

KEITHLEY

A GREATER MEASURE OF CONFIDENCE

7012-C 7012-S

4x10 Matrix Cards



- 4x10 2-pole matrix
- Available with screw terminal or mass terminated connections
- Rows connect to 7001/7002 backplane for easy matrix expandability
- 500nV, 100pA offsets

Ordering Information

7012-C 4x10, 2-Pole Matrix with 96-pin Mass Terminated Connector Board

7012-S 4x10, 2-Pole Matrix with Screw Terminal Connector Board

ACCESSORIES AVAILABLE

FOR 7012-C

7011-KIT-R	96-pin Female Connector Kit
7011-MTC-1	96-pin Mass Terminated Cable, Female to Female, 1m
7011-MTC-2	96-pin Mass Terminated Cable, Female to Female, 2m

FOR 7012-S

7012-ST	Extra Screw Terminal Connection Board
---------	---------------------------------------

SERVICES AVAILABLE

7012-C-3Y-EW	1-year factory warranty extended to 3 years from date of shipment
7012-S-3Y-EW	1-year factory warranty extended to 3 years from date of shipment

The 7012 provides 4 rows by 10 columns of 2-pole matrix switching. The four rows of this card can be connected to the analog backplane within the 7001 or 7002 to make a larger matrix (4x20) or use it with the 7011 multiplexer card for greater flexibility through row expansion. Each row is connected to the backplane with its own jumpers that can be removed to isolate an individual row from the backplane.

MATRIX CONFIGURATION: 4 rows by 10 columns. Jumpers can be removed to isolate any row from the backplane.

CONTACT CONFIGURATION: 2-pole Form A (Hi, Lo).

CONNECTOR TYPE:

7012-C: 96-pin male DIN connector.

7012-S: Screw terminal, #16AWG maximum wire size, with .092 inch O.D. 28 conductors per card maximum. #22AWG typical wire size with .062 inch O.D. 88 conductors per card maximum.

MAXIMUM SIGNAL LEVEL:

DC Signals: 110V DC between any two pins, 1A switched. 30VA (resistive load).

AC Signals: 125V rms and 175V AC peak, between any two pins, 1A switched, 60VA (resistive load).

COMMON MODE VOLTAGE: 175V peak, any pin to chassis.

CONTACT LIFE: Cold Switching: 10⁸ closures. At Maximum Signal Levels: 10⁵ closures.

CHANNEL RESISTANCE (per conductor): <1Ω.

CONTACT POTENTIAL:

7012-C: <1μV per channel contact pair <3μV typical per single contact.

7012-S: <500nV per channel contact pair <1.5μV typical per single contact.

OFFSET CURRENT: <100pA.

ACTUATION TIME: 3ms.

ISOLATION: Path: >10⁹Ω, <50pF. **Differential:** >10⁹Ω, <200pF. **Common Mode:** >10⁹Ω, <400pF.

CROSSTALK (1MHz, 50Ω Load): <-40dB.

INSERTION LOSS (50Ω Source, 50 Load): <0.1dB below 1MHz, <3dB below 2MHz.

RELAY DRIVE CURRENT (per relay): 16mA.

EMC: Conforms to European Union Directive 89/336/EEC.

SAFETY: Conforms to European Union Directive 73/23/EEC (meets EN61010-1/IEC 1010).

ENVIRONMENT: Operating: 0° to 50°C, up to 35°C <80% RH. **Storage:** -25°C to 65°C.

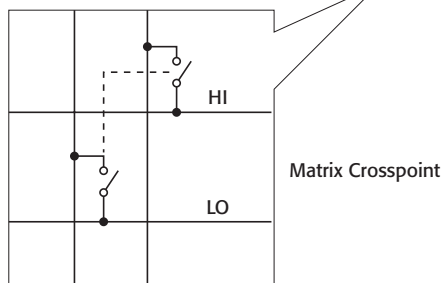
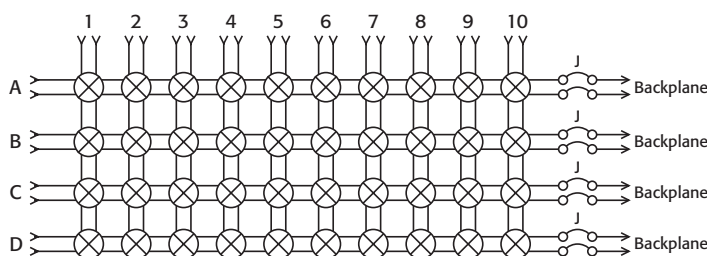

7013-C 7013-S

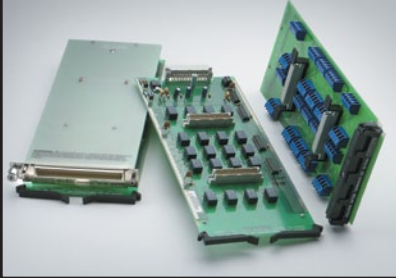

- 20 independent 2-pole switches
- 500nV, 100pA offsets

Ordering Information

- 7013-C** 20-channel, 2-pole Independent Switch with 96-pin Mass Terminated Connector Board
- 7013-S** 20-channel, 2-pole Independent Switch with Screw Terminal Connector Board

7014



- Built-in temperature reference for thermocouple cold junction compensation
- 39-channel, 2-pole multiplexer
- For thermocouple and general purpose signal switching

Ordering Information

- 7014** 39-channel Thermocouple Scanner with Screw Terminal Connector Board

20-channel Isolated Switch Cards

This isolated switch card contains 20 independent channels that can be connected in a wide variety of configurations. Each channel is 2-pole. The isolated switch configuration provides the greatest flexibility because the switches can be connected as needed. Both sides of each 2-pole relay are available for connection.

RELAY SWITCH CONFIGURATION: 20 independent channels of 2-pole switching.

CONTACT CONFIGURATION: 2-pole Form A (Hi, Lo).

CONNECTOR TYPE: 7013-C: 96-pin male DIN connector.

7013-S: Screw terminal, #16AWG maximum wire size, with 0.092 inch O.D. 28 conductors per card maximum. #22AWG typical wire size with 0.062 inch O.D. 88 conductors per card maximum.

MAXIMUM SIGNAL LEVEL: DC Signals: 110V DC between any two pins, 1A switched. 30VA (resistive load).

AC Signals: 125V rms and 175V AC peak, between any two pins, 1A switched, 60VA (resistive load).

COMMON MODE VOLTAGE: 175V peak, any pin to chassis.

CONTACT LIFE: Cold Switching: 10⁸ closures.

At Maximum Signal Levels: 10⁵ closures.

CHANNEL RESISTANCE (per conductor): <1Ω.

OFFSET CURRENT: <100pA.

CONTACT POTENTIAL: 7013-C: <2μV per channel contact pair (Hi, Lo); <5μV per single contact. 7013-S: <2μV per contact pair (Hi, Lo); <5μV per single contact.

ACTUATION TIME: 3ms.

ISOLATION: Channel to Channel: >10¹⁰Ω, <25pF.

Differential: >10¹⁰Ω, <50pF. **Common Mode:** >10¹⁰Ω, <100pF.

CROSSTALK (1MHz, 50Ω Load): <-50dB.

INSERTION LOSS (50Ω Source, 50Ω Load): <0.1dB below 1MHz, <3dB below 10MHz.

RELAY DRIVE CURRENT (per relay): 16mA.

EMC: Conforms to European Union Directive 89/336/EEC.

SAFETY: Conforms to European Union Directive 73/23/EEC (meets EN61010-1/IEC 1010).

ENVIRONMENT: Operating: 0° to 50°C, up to 35°C <80% RH. **Storage:** -25°C to 65°C.

ACCESSORIES AVAILABLE

FOR 7013-C

- 7011-KIT-R 96-pin Female Connector Kit
7011-MTC-1 96-pin Mass Terminated Cable, Female to Female, 1m
7011-MTC-2 96-pin Mass Terminated Cable, Female to Female, 2m

FOR 7013-S

- 7013-ST Extra Screw Terminal Connection Board

SERVICES AVAILABLE

- 7013-C-3Y-EW 1-year factory warranty extended to 3 years from date of shipment
7013-S-3Y-EW 1-year factory warranty extended to 3 years from date of shipment

Thermocouple Multiplexer

39 Channels of T/C or General Purpose Switching

The 7014 can multiplex up to 39 cold junction compensated thermocouple channels. The built-in reference junction can be measured to determine the temperature of the isothermal connection board for accurate temperature measurements. The reference junction sensing device outputs a calibrated reference voltage that is linearly related to the temperature of the isothermal connection board.

The 7014 card with the 7001 or 7002 mainframe is designed to be used with the Keithley Model 2000, 2001, and 2010 DMMs. The 2001 uses the reference junction output from the 7014 to display properly compensated and linearized temperature readings from the thermocouples.

MULTIPLEX CONFIGURATION: Four independent 1×10 2-pole multiplex banks. Adjacent banks can be connected together. Jumpers can be removed to isolate any bank from the backplane. Channel one in the bank A multiplexer is used for the cold junction sensor.

CONTACT CONFIGURATION: 2-pole Form A (Hi, Lo).

CONNECTOR TYPE: Screw terminal, #16AWG maximum wire size, with 0.092 inch O.D. 28 conductors per card maximum. #22AWG typical wire size per conductor, with 0.062 inch O.D. 86 conductors per card maximum.

REFERENCE OUTPUT: +200μV/°C (+54.63mV at 0°C).

TOTAL REFERENCE JUNCTION MEASUREMENT ACCURACY (1 Year): ±0.45°C (18°–28°C); ±0.7 (0°–18°C and 28°–50°C).

WARMUP: 2 hours to rated accuracy in mainframe.

COMMON MODE VOLTAGE: 175V peak, any pin to chassis.

MAXIMUM SIGNAL LEVEL: DC Signals: 110V DC between any two pins, 1A switched. 30VA (resistive load).

AC Signals: 125V rms and 175V AC peak, between any two pins, 1A switched, 60VA (resistive load).

CONTACT LIFE: Cold Switching: 10⁸ closures.

At Maximum Signal Levels: 10⁵ closures.

CHANNEL RESISTANCE (per conductor): <1Ω.

CONTACT POTENTIAL: <1μV per channel contact pair; <2μV typical per single contact.

OFFSET CURRENT: <100pA.

ACTUATION TIME: 3ms.

ISOLATION: Bank: >10¹⁰Ω, <25pF.

Channel to Channel: >10¹⁰Ω, <50pF.

Differential: Configured as 1×10: >10¹⁰Ω, <100pF.

Configured as 1×40: >10¹⁰Ω, <200pF.

Common Mode: Configured as 1×10: >10¹⁰Ω, <300pF.

Configured as 1×40: >10¹⁰Ω, <900pF.

CROSSTALK (1MHz, 50Ω Load): Bank: <-40dB.

Channel: <-40dB.

INSERTION LOSS (50Ω Source, 50Ω Load): <0.1dB below 1MHz, <3dB below 2MHz.

RELAY DRIVE CURRENT (per relay): 20mA.

EMC: Conforms to European Union Directive 89/336/EEC.

SAFETY: Conforms to European Union Directive 73/23/EEC (meets EN61010-1/IEC 1010).

ENVIRONMENT: Operating: 0° to 50°C, up to 35°C <80% RH. **Storage:** -25°C to 65°C.

ACCESSORIES AVAILABLE

- 7014-ST Extra Screw Terminal Connection Board

SERVICES AVAILABLE

- 7014-3Y-EW 1-year factory warranty extended to 3 years from date of shipment

1.888.KEITHLEY (U.S. only)

www.keithley.com

KEITHLEY

A GREATER MEASURE OF CONFIDENCE

7015-C 7015-S

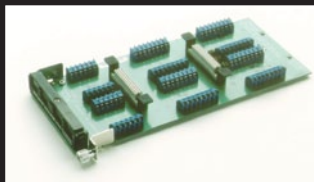

- Quad 1×10 (40-channel) solid-state multiplexer
- 30,000 hours MTBF
- Scan/measure over 300 ch/s

Ordering Information

- 7015-C** 40-channel, 2-pole Independent Switch with 96-pin Mass Terminated Connector Board
- 7015-S** 40-channel, 2-pole Independent Switch with Screw Terminal Connector Board

7016A

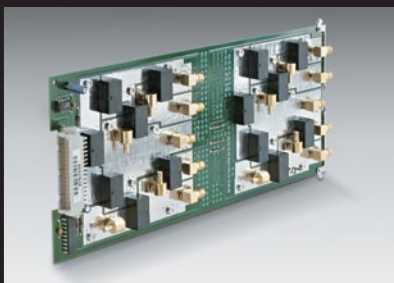

- DC to 2GHz, 50Ω, signal switching
- Off channels can be resistively terminated

Ordering Information

- 7016A** Dual 1×4, 2GHz, 50Ω Multiplexer with Optional Termination

40-channel Solid State Multiplexer Cards

Quad 1×10 Configuration

The Model 7015 40-channel solid state multiplexer is designed for multipoint measurement applications that require high reliability and increased scanning speeds. With an MTBF of more than 30,000 hours, the 7015 can handle applications that require continuous use over longer periods of time. The solid state switch technology also provides fast switching times for scanning rates of over 300 channels/measurements per second when used with the 7002/2001 or 7001/2001 combination.

MULTIPLEX CONFIGURATION: 4 independent 1×10 2-pole multiplex banks or 2 independent 1×10 4-pole multiplex banks. Adjacent banks can be connected together. Jumpers can be removed to isolate any bank from the backplane.

CONTACT CONFIGURATION: 2-pole Form A (Hi, Lo).

CONNECTOR TYPE:

7015-C: 96-pin male DIN connector.

7015-S: Screw terminal, #16AWG maximum wire size, with 0.092 inch O.D. 28 conductors per card maximum. #22AWG typical wire size with 0.062 inch O.D. 88 conductors per card maximum.

MAXIMUM SIGNAL LEVEL: 175V peak between any two pins, 34mA resistive load, 0.3VA max., 1×10⁶V-Hz max.

COMMON MODE VOLTAGE: 175V peak, any pin to chassis.

CONTACT TYPE: Solid state switch.

CHANNEL RESISTANCE (per conductor): <210Ω.

CONTACT POTENTIAL: 7015-C: <5μV per channel contact pair.

7015-S: <4μV per channel contact pair.

OFFSET CURRENT: <1nA.

ACTUATION TIME: <500μs.

ISOLATION: Bank: >10³Ω, <25 pF.

Channel to Channel: >10³Ω, <50 pF.

Differential: Configured as 1×10: >10³Ω, <100pF.

Configured as 1×40: >10³Ω, <200pF.

Common Mode: Configured as 1×10: >10³Ω, <375pF.

Configured as 1×40: >10³Ω, <1100pF.

INSERTION LOSS (50Ω Source, 1MΩ Load): <0.1dB below 250kHz, <3dB below 500kHz.

ACCESSORIES AVAILABLE

FOR 7015-C

7011-KIT-R 96-pin Female Connector Kit

7011-MTC-1 96-pin Mass Terminated Cable, Female to Female, 1m

7011-MTC-2 96-pin Mass Terminated Cable, Female to Female, 2m

FOR 7015-S

7015-ST Extra screw terminal connection board

SERVICES AVAILABLE

7015-C-3Y-EW 1-year factory warranty extended to 3 years from date of shipment

7015-S-3Y-EW 1-year factory warranty extended to 3 years from date of shipment

2GHz RF Switch Card

Dual 1×4 Configuration, 50Ω

The Model 7016A has two independent bi-directional 1×4 multiplexers for the Models 7001 and 7002 Switch Mainframes. The characteristic impedance of the card is 50Ω. Signal connections are made to the card with SMA connectors. Off channels can be resistively terminated. SMB jack connectors, provided on the card, are designed to be used with user-supplied terminators to minimize signal reflection.

MULTIPLEXERS PER CARD: Two 1×4s (with isolated ground).

CHARACTERISTIC IMPEDANCE: 50Ω nominal.

CHANNELS PER MULTIPLEXER: 4.

CONTACT CONFIGURATION: 1 pole Form A common shield.

RELAY DRIVE CURRENT: 120mA.

CONNECTOR TYPE: SMA.

RECOMMENDED CABLE: RG-223/U.

TERMINATION: User supplied 50Ω SMB termination (on unselected inputs).

ACTUATION TIME: 8ms.

MAXIMUM VOLTAGE: Any terminal (center or shield) to any other center or chassis: 30V.

MAXIMUM CARRY CURRENT: 0.5A.

MAXIMUM CARRY POWER: 10VA up to 900MHz, 3VA @ 2GHz.

ISOLATION: Multiplexer to Multiplexer: >1GΩ. **Center to Shield:** >1GΩ, <50pF. **Channel to Channel:** >100MΩ.

RISE TIME: <200ps.

SIGNAL DELAY: <3ns; channels matched to 50ps.

CONTACT POTENTIAL: <6μV.

CONTACT RESISTANCE: 0.5Ω.

CONTACT LIFE: 3×10⁵ @ 30V @ 10mA, 3×10⁵ @ 900MHz, 1W, 1×10⁶ @ cold switching.

ENVIRONMENT: Operating: 0° to 50°C; up to 35°C at 80% RH. **Storage:** -25°C to 65°C.

EMC: Conforms with European Union Directive 89/336/EEC.

SAFETY: Conforms with European Union Directive 73/23/EEC (meets EN61010-1/IEC 1010).

AC PERFORMANCE:

For $Z_L = Z_S = 50\Omega$	≤10 MHz	≤100 MHz	≤500 MHz	≤1 GHz	≤2 GHz
Insertion Loss (dB):	<0.3	<0.6	<1.0	<1.3	<3.0
Crosstalk (dB): ¹					
Channel-channel	<-90	<-80	<-65	<-55	<-45
Switch-Switch	<-90	<-80	<-70	<-65	<-45
VSWR	<1.06	<1.1	<1.2	<1.6	≤1.9

¹ Specification assumes 50Ω termination.

SERVICES AVAILABLE

7016A-3Y-EW 1-year factory warranty extended to 3 years from date of shipment

7017

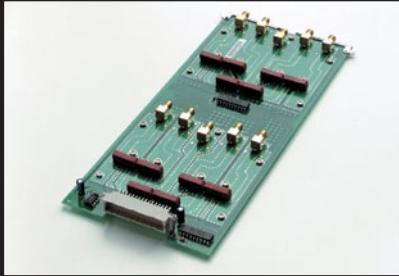

- DC to 800MHz, 50Ω, signal switching
- <10mΩ contact resistance variation

Ordering Information

7017 Dual 1×4, 800MHz, 50Ω Multiplexer with SMA Connectors

7018-C 7018-S

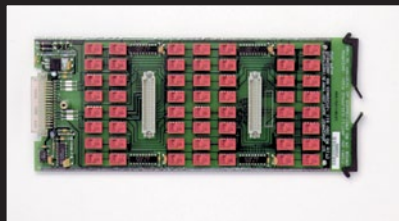

- Dual 1×14 (28-channel) multiplexer for 3- or 6-pole operation
- Connects to 7001/7002 backplane for easy expandability

Ordering Information

7018-C Quad 1×10 Multiplexer with 96-pin Mass Terminated Connector Board

7018-S Dual 1×14 Multiplexer with Screw Terminal Connector Board

800MHz RF Switch Card

Dual 1×4 Configuration, 50Ω

The Model 7017 800MHz Multiplexer Card combines the stability, durability, and bandwidth that high-volume production testing applications demand. Its reed relay design ensures extremely repeatable contact resistance, even when operating at high speeds continuously. With an 800MHz bandwidth, the 7017 is suitable for switching a wide range of signals, making it a good choice for testing a variety of electronic components and assemblies, from diodes and capacitors to disk drive heads and other electronic subassemblies.

MULTIPLEXERS PER CARD: 2 (with isolated ground).
CHARACTERISTIC IMPEDANCE: 50Ω nominal.
CHANNELS PER MULTIPLEXER: 4.
CONTACT CONFIGURATION: 1 pole Form A, common shield.
RELAY DRIVE CURRENT: 26mA per channel.
CONNECTOR TYPE: SMA.
RECOMMENDED CABLE: RG-223/U.
ACTUATION TIME: 1ms.
MAXIMUM VOLTAGE: Any terminal (center or shield) to any other terminal or chassis: 42V peak.
MAXIMUM CURRENT: 1A carry/0.5A switched.

MAXIMUM POWER: 10VA.
ISOLATION: Multiplexer to Multiplexer: >10°Ω. **Center to Shield:** >10°Ω, <60pF. **Channel to Channel:** >10°Ω.
CONTACT POTENTIAL: <25μV.
CONTACT RESISTANCE: <0.5Ω initial, 1Ω at end of contact life.
CONTACT LIFE: 1V, 10mA: 10⁸ closures. 20V, 0.5A: 5×10⁴ closures.

AC Performance:

For $Z_L = Z_S = 50\Omega$	≤10 MHz	≤100 MHz	≤500 MHz	≤800 MHz
Insertion Loss (dB):	<0.35	<1.0	<2.0	<3.0
Crosstalk (dB)¹				
Channel-channel	<-60	<-40	<-35	<-30
Mux. to Mux.	<-80	<-60	<-60	<-55

VSWR: <1.2 @ 100MHz.

¹Specification assumes 50Ω termination.

EMC: Conforms to European Union Directive 89/336/EEC.
SAFETY: Conforms to European Union Directive 73/23/EEC (meets EN61010-1/IEC 1010).
ENVIRONMENT: Operating: 0° to 50°C, up to 35°C at <80% R.H. **Storage:** -25°C to 65°C.

SERVICES AVAILABLE

7017-3Y-EW 1-year factory warranty extended to 3 years from date of shipment

28-channel 3-Pole Multiplexer

The Model 7018 28-channel multiplexer has two independent banks of 1×14 switching. Each channel is 3-pole. The two banks can be combined for a variety of different switching configurations. Used separately, they provide a dual 1×14 3-pole configuration. Onboard jumpers can connect the outputs together for a single 1×28 3-pole arrangement. Both the 7001 and 7002 switch systems can use the two banks in parallel for 6-pole operation in a 1×14 configuration.

MULTIPLEX CONFIGURATION: 2 independent 1×14 3-pole multiplex banks or one 1×14 6-pole multiplexer. Jumpers can be removed to isolate any bank from the backplane.
CONTACT CONFIGURATION: 3-pole Form A.
CONNECTOR TYPE: 7018-C: 96-pin male DIN connector. 7018-S: Screw terminal, #16AWG maximum wire size, with 0.092 inch O.D. 28 conductors per card maximum. #22AWG typical wire size with 0.062 inch O.D. 90 conductors per card maximum.
MAXIMUM SIGNAL LEVEL: DC Signals: 110V DC between any two pins, 1A switched, 30VA (resistive load). **AC Signals:** 125V rms or 175V AC peak, between any two pins, 1A switched, 60VA (resistive load).
COMMON MODE VOLTAGE: 175V peak, any pin to chassis.
CONTACT LIFE: Cold Switching: 10⁸ closures. **At Maximum Signal Levels:** 10⁵ closures.
CHANNEL RESISTANCE (per conductor): <1.5Ω.
CONTACT POTENTIAL: <5μV per single contact.
OFFSET CURRENT: <100pA.
ACTUATION TIME: 3ms.

CROSS TALK (1MHz, 50Ω Load): Bank: <-40dB. **Channel:** <-40dB.

ISOLATION: Bank: >10°Ω, <25pF. **Channel to Channel:** >10°Ω, <50pF. **Differential:** Configured as 1×14 >10°Ω, <100pF. Configured as 1×28 >10°Ω, <200pF. **Common Mode:** Configured as 1×14 >10°Ω, <400pF. Configured as 1×28 >10°Ω, <650pF.

INSERTION LOSS (50Ω Source, 50Ω Load): <0.2dB below 1MHz, <3dB below 2MHz.

RELAY DRIVE CURRENT (per channel): 59mA. (Maximum of 11 channels on at same time.)

EMC: Conforms to European Union Directive 89/336/EEC.

SAFETY: Conforms to European Union Directive 73/23/EEC (meets EN61010-1/IEC 1010).

ENVIRONMENT: Operating: 0°C to 50°C, up to 35°C at 80% RH. **Storage:** -25°C to 65°C.

ACCESSORIES AVAILABLE

FOR 7018-C

7011-KIT-R 96-pin Female Connector Kit
 7011-MTC-1 96-pin Mass Terminated Cable, Female to Female, 1m
 7011-MTC-2 96-pin Mass Terminated Cable, Female to Female, 2m

FOR 7018-S

7018-ST Extra Screw Terminal Connection Board

SERVICES AVAILABLE

7018-C-3Y-EW 1-year factory warranty extended to 3 years from date of shipment
 7018-S-3Y-EW 1-year factory warranty extended to 3 years from date of shipment

1.888.KEITHLEY (U.S. only)
www.keithley.com

KEITHLEY

7019-C

6-Wire Ohms Matrix Card

For use with Series 2400 SourceMeter® Instruments

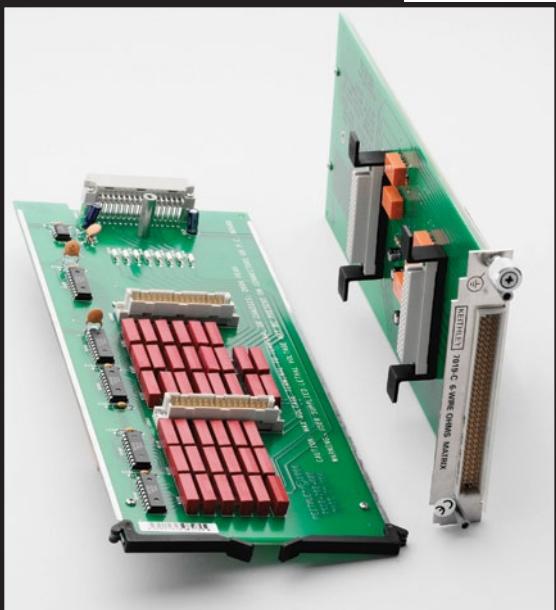

- For high speed production test of resistor networks
- Supports Series 2400's 6-wire Ω measurements
- Dual 3×6 matrix configuration
- 100,000,000 closure life
- 0.5Ω contact resistance
- 200V, 1A rated

Ordering Information

7019-C Dual 3×6 Matrix with 96-pin Mass Terminated Connector Board

The Model 7019-C 6-Wire Ohms Matrix Card is specifically designed for automated production testing of resistor network devices in conjunction with the six-wire ohms function of Keithley's Series 2400 SourceMeter instruments and Model 7001 or 7002 Switch Mainframes. When these instruments are combined with the 7019-C in a production test system, the "per element" test time is typically less than 10ms, with maximum speeds typically less than 4ms.

Flexible Matrix Configuration

The Model 7019-C is configured as two independent 3×6 matrices. One is designed for switching the Series 2400 instrument's Force+, Force-, and Guard signals, while the other switches its Sense+, Sense-, and Guard Sense terminals. This configuration makes it possible to connect any of the SourceMeter instrument's force, sense, or guard outputs to any pin of the DUT for wide testing flexibility. Each of the card's 36 crosspoints is a single-pole switch. Closing the appropriate crosspoint switch allows any of the three rows in one matrix to be connected to any of the six columns in the same matrix. In addition to these matrices, two utility rows are available to handle other switching tasks, such as temperature monitoring.

More Information

For more information on 6-wire ohms measurements and using the Model 7019-C in testing resistor networks, refer to the section on SourceMeter instruments and to Application Note #1818 at www.keithley.com.

MATRIX CONFIGURATION: Dual 3 rows by 6 columns, plus two utility pathways with two 2-channel multiplexer rows. Jumpers can be removed to isolate any row from the backplane.

CONTACT CONFIGURATION: 1 pole Form A.

CONNECTOR TYPE: 96-pin male DIN connector.

MAXIMUM VOLTAGE: Any input to any other input or chassis: 200V peak.

MAXIMUM CURRENT: 1A carry/0.5A switched.

MAXIMUM POWER: 10VA.

CONTACT LIFE: 1V, 10mA: 10⁸ closures.

20V, 0.5A: 5×10⁴ closures.

CHANNEL RESISTANCE: 0.5Ω initial, 1 Ω at end of contact life.

CONTACT POTENTIAL: $25\mu V$ per single contact or pair.

ACTUATION TIME: 500 μs .

ISOLATION: Path: >10⁶ Ω , $50 pF$. **Differential:** >10⁶ Ω , $400 pF$. **Common Mode:** >10⁶ Ω , $400 pF$.

OFFSET CURRENT: $100 pA$.

INSERTION LOSS (50 Ω Source, 50 Ω Load): $0.35 dB$ below 1MHz, $3 dB$ below 2MHz.

CROSSTALK (1MHz, 50 Ω Load): -40dB.

RELAY DRIVE CURRENT: 15mA per channel.

ACCESSORIES AVAILABLE

7011-KIT-R	96-pin Female Connector Kit
7019C-MTC-1	6-pin Extender Cable, 2m
7019C-MTCL-2	6-pin Extender and Instrument Cable, 2m

SERVICES AVAILABLE

7019-C-3Y-EW	1-year factory warranty extended to 3 years from date of shipment
--------------	---

7020 7020-D

Digital I/O Cards 40 Inputs, 40 Outputs

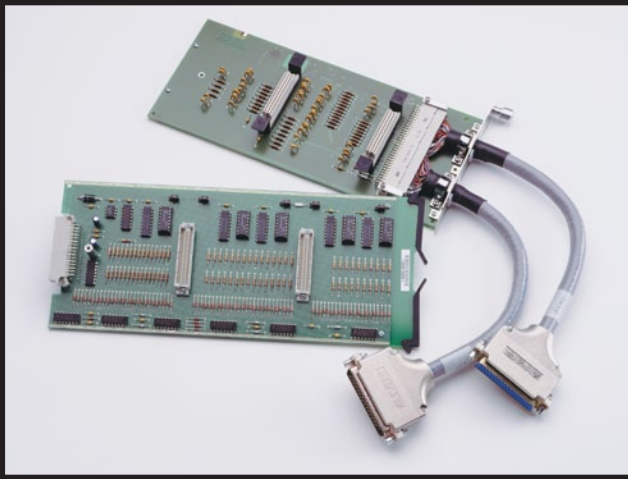

The Model 7020 and 7020-D Digital I/O Interface Cards provide high-density digital input/output capabilities in an easy-to-control form. The 7020 and 7020-D both have 40 independent inputs and 40 independent outputs, so they're well-suited for monitoring and controlling large automated test applications compactly and cost-effectively. The 7020 provides a 96-pin mass terminated connector. The 7020-D has two heavy duty 50-pin D-sub connectors at the ends of short cables. The D-sub connector version is designed for industrial/production applications where repeated connects/disconnects with external cables are required.

- 80-bit control – 40 in/40 out
- Input and output protection
- Use internal 5.3V power supply or external power supply

Ordering Information

7020	Digital I/O Card with 96-pin Mass Terminated Connector Board
7020-D	Digital I/O Card with D-sub Connectors

Accessories Supplied

With 7020: 7011-KIT-R
96-pin Female Connector Kit

Output Channel

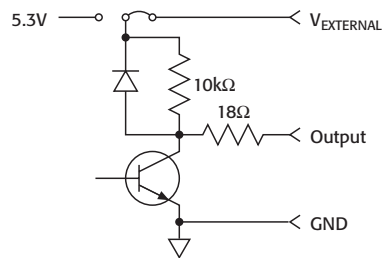

Input Channel

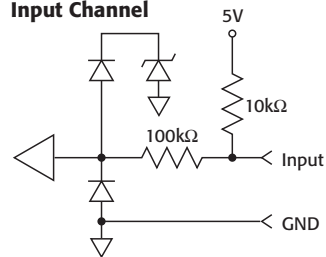

ACCESSORIES AVAILABLE

FOR 7020

7011-KIT-R	96-pin Female Connector Kit
7020-MTC-2	96-pin Mass Terminated Cable, Female to Female, 2m

FOR 7020-D

7020-DT	Extra Connector Board
---------	-----------------------

SERVICES AVAILABLE

7020-3Y-EW	1-year factory warranty extended to 3 years from date of shipment
7020-D-3Y-EW	1-year factory warranty extended to 3 years from date of shipment

CONNECTOR:

7020: 96-pin male DIN connector.

7020-D: Cables with 50-pin male and female D-sub connectors.

7020-DT: Mass terminated card with D-sub connectors.

DIGITAL I/O CAPABILITY: 40 independent inputs, 40 independent outputs.

OUTPUT SPECIFICATIONS:

CONFIGURATION: 40 open-collector drivers with factory installed 10kΩ pull-up resistors. Pull-up resistors can be removed when driving external pull-up devices. Each driver has an internal flyback diode.

PULL UP VOLTAGE: 5.3V internally supplied, external connection provided for user supplied voltage 25V max. Removal of internal jumper allows use of two different pull-up voltages.

MAXIMUM SINK CURRENT: Per Channel: 65mA. Per Bank (8 bits): 500mA. Per Card: 1A.

CURRENT LIMIT: Positive Temperature Coefficient circuit protector in series with each output. Output protection resistance <18Ω.

COLLECTOR-EMITTER SATURATION VOLTAGE: <0.75V @ 1mA. <1V @ 65mA.

INPUT SPECIFICATIONS:

CONFIGURATION: 40 inputs with internal 10kΩ pull-up resistors.

CHARACTERISTICS:

Input logic low voltage:	0.8 V max.
Input logic high voltage:	2 V min.
Input logic low current:	-600 μA max. @ 0V
Input logic high current:	50 μA max. @ 5V

MAXIMUM VOLTAGE LEVEL: 42V peak.

7021



- 30-channel, 2-pole multiplexer
- 20 control bits – 10 in/10 out
- Multiplexer connects to 7001/7002 backplane for easy expandability
- 250mA digital output sink capacity
- Digital input and output protection built in

Ordering Information

7021 30-channel Multiplexer with Digital I/O

Accessories Supplied

7011-KIT-R 96-pin Female Connector Kit

Multiplexer-Digital I/O Card

with 1×12 Plus 1×18 Multiplexer, 10 Digital Inputs & 10 Digital Outputs

The Model 7021 Multiplexer-Digital I/O Card combines high-density signal switching with digital control on a single card. This space-saving design is well-suited for configuring compact automated production test applications. The Model 7021 card contains two independent 2-pole multiplexers—one 1×12 bank and one 1×18 bank. For larger applications, these multiplexers can be combined to form a 1×30 two-pole multiplexer. In addition to the Model 7021's signal routing capabilities, it can also sense the state of 10 digital inputs and generate 10 digital output states. Each input channel can be set up for either pull-up or pull-down operation through the card's 10kΩ onboard resistors. This allows microswitches and similar devices to be monitored directly, without the need for level-shifting interface circuitry.

ANALOG MULTIPLEXER SPECIFICATIONS

MULTIPLEXER CONFIGURATION: Independent 1×12 and 1×18 multiplex banks. Adjacent banks can be connected together. Jumpers can be removed to isolate any bank from the backplane.

CONTACT CONFIGURATION: 2-pole Form A (HI, LO).

MAXIMUM SIGNAL: 110V DC, 110V rms, 155V peak between any two inputs or chassis, 1A switched, 30VA (resistive load).

CONTACT LIFE: Cold Switching: 10⁸ closures.

Maximum Signal Levels: 10⁵ closures.

CHANNEL RESISTANCE (per conductor): <1.25Ω.

CONTACT POTENTIAL: <3μV per channel contact pair. <9μV per single contact.

OFFSET CURRENT: <100pA.

ACTUATION TIME: <3ms.

ISOLATION:¹

Bank: >10⁹Ω, <25pF.

Channel to Channel: >10⁹Ω, <50pF.

Differential: Configured as 1×12: >10⁹Ω, <100pF.
Configured as 1×18: >10⁹Ω, <150pF.
Configured as 1×30: >10⁹Ω, <200pF.

Common Mode: Configured as 1×12: >10⁹Ω, <200pF.
Configured as 1×18: >10⁹Ω, <250pF.
Configured as 1×30: >10⁹Ω, <350pF.

CROSSTALK¹ (1MHz, 50Ω Load): <-40dB.

INSERTION LOSS¹ (50Ω Source, 50Ω Load): <0.25dB below 1MHz, <3dB below 10MHz.

RELAY DRIVE CURRENT (per relay): 16mA.

NOTES

1. Specifications apply with no more than one channel closed.

ACCESSORIES AVAILABLE

7011-KIT-R 96-pin Female Connector Kit

SERVICES AVAILABLE

7021-3Y-EW 1-year factory warranty extended to 3 years from date of shipment

DIGITAL I/O SPECIFICATIONS

DIGITAL I/O CAPABILITY: 10 independent inputs. 10 independent outputs.

OUTPUT:

Configuration: 10 open-collector drivers with factory installed 10kΩ pull-up resistors. Each driver has an internal flyback diode.

Pull-Up Voltage: 5V internally supplied, external connection provided for user supplied voltage up to 42V max. Outputs short circuit protected up to 25V.

Maximum Sink Current: Per Channel: 250mA. Per Card: 1A.

Logic: Hardware user configurable for negative or positive true logic levels.

INPUT:

Configuration: 10 inputs with internal 10kΩ pull-up resistors provided. Input resistors can be set for pull-up or pull-down configuration.

MAXIMUM VOLTAGE LEVEL: 42V peak.

LOGIC: Positive true.

GENERAL

CONNECTOR TYPE: 96-pin male DIN connector (7011-KIT-R mating connector included).

ENVIRONMENT:

Operating: 0° to 50°C, up to 35°C <80% RH.

Storage: -25° to 65°C.

EMC: Conforms to European Union Directive 89/336/EEC.

SAFETY: Conforms to European Union Directive 73/23/EEC (meets EN61010-1/IEC 1010).

Multiplexer Configuration

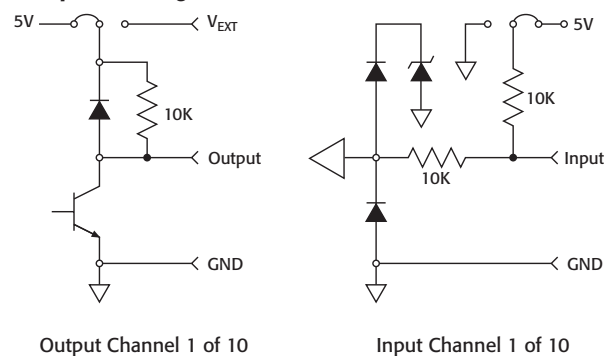

Digital I/O Configuration

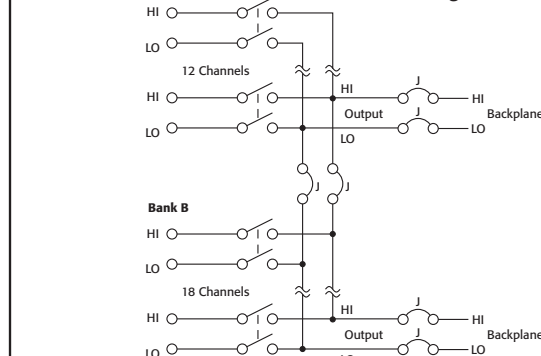

1.888.KEITHLEY (U.S. only)

www.keithley.com

KEITHLEY

A GREATER MEASURE OF CONFIDENCE

Use with 7001 and 7002 switch mainframes

SWITCHING AND CONTROL

7035



- Great fit for low frequency telecom test

Ordering Information

7035 9 Bank 1×4 Multiplexer Switching Card

Accessories Supplied

7011-KIT-R 96-pin Female Connector Kit

7038

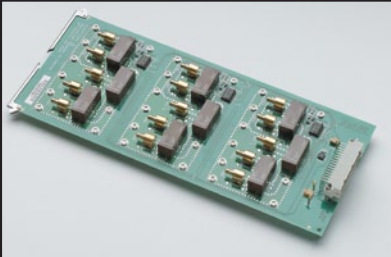

- DC to 2GHz, 75Ω, signal switching
- High channel to channel isolation
- Miniature SMB connectors

Ordering Information

7038 Three 1×4, 2GHz, 75Ω Multiplexer

10MHz 1×4 Multiplexer Card

9 Independent 1×4 2-Pole Multiplexers

The Model 7035 9-Bank Multiplexer Card has nine 1×4 multiplexers. The switch contact configuration for each channel is 2-pole form A. The card's nine banks can be combined for a wide variety of switching configurations using external connections. This flexibility makes the Model 7035 well-suited for production testing of a variety of telecommunications products and systems and low power portable devices.

MULTIPLEX CONFIGURATION: 9 independent 1×4 2-pole multiplex banks.

CONTACT CONFIGURATION: 2-pole Form A (Hi, Lo).

CONNECTOR TYPE: 96-pin male DIN connector (7011-KIT-R mating connector included).

MAXIMUM SIGNAL LEVEL: 60V DC, 30V rms, 42V peak between any two inputs or chassis, 1A switched. 30VA (resistive load).

CONTACT LIFE: Cold Switching: 10⁸ closures. At Maximum Signal Levels: 10⁵ closures.

CHANNEL RESISTANCE (per conductor): <1Ω.

CONTACT POTENTIAL: <2μV per channel contact pair. <5μV typical per single contact.

OFFSET CURRENT: <100pA.

ACTUATION TIME: 3ms.

ISOLATION: Bank: >10°Ω, <25 pF.
Channel to Channel: >10°Ω, <50 pF.
Differential: >10°Ω, <100pF.
Common Mode: >10°Ω, <200pF.

CROSSTALK (1MHz, 50Ω Load): Bank: <-40dB.
Channel: <-40dB.

INSERTION LOSS (50Ω Source, 50 Load): <0.25dB below 1MHz, <3dB below 10MHz.

RELAY DRIVE CURRENT (per relay): 16mA.

ACCESSORIES AVAILABLE

7011-KIT-R	96-pin Female Connector Kit
7035-MTC-2	96-pin Mass Terminated Cable, Female to Female, 2m

SERVICES AVAILABLE

7035-3Y-EW	1-year factory warranty extended to 3 years from date of shipment
------------	---

2GHz RF Switch Card

3 Isolated 1×4 Multiplexers, 75Ω

The Model 7038 75Ω 2.0GHz Multiplexer Card is designed to speed testing and evaluation of a broad-range of telecommunications hardware, including coaxial cable-based equipment, cable television equipment, and high-speed Internet access products. The card simplifies automated switching of high-frequency RF signals, even those with bandwidths of up to 2GHz.

CHARACTERISTIC IMPEDANCE: 75Ω nominal.

MULTIPLEXERS PER CARD: 3 (with isolated ground).

CHANNELS PER MULTIPLEXER: 4.

CONTACT CONFIGURATION: 1-pole, 1 of 4 tree. Channels 1, 5, and 9 normally closed.

RELAY DRIVE CURRENT: 154mA per channel.

CONNECTOR TYPE: 75Ω miniature SMB receptacle.

ACTUATION TIME: 6ms.

MAXIMUM VOLTAGE: Any terminal (center or shield) to any other terminal or chassis: 24V.

MAXIMUM CURRENT: 10mA DC.

MAXIMUM POWER: 10W @ 1.2GHz.

ISOLATION: Multiplexer to Multiplexer: >1GΩ. Center to Shield: >1GΩ, 60pF. Channel to Channel: >100MΩ.

SIGNAL DELAY: <1ns.

CONTACT POTENTIAL: 15μV.

CONTACT LIFE: 3×10⁵ closures @ 24VDC, 10mA DC; 1×10⁵ closures @ 10W, 1.2GHz signal; 5×10⁸ closures @ cold switching.

CONTACT RESISTANCE: <1Ω.

AC PERFORMANCE:

For $Z_L = Z_S = 75\Omega$	<10 MHz	≤100 MHz	≤500 MHz	≤900 MHz	≤2 GHz
Insertion Loss (dB)	<0.25	<0.5	<1.0	<1.5	<3.0
Crosstalk (dB)					
Channel-to-channel	<-90	<-80	<-65	<-55	<-40
Mux. to Mux.	<-90	<-80	<-70	<-60	<-55
VSWR	<1.2	<1.25	<1.5	<1.5	<2.2

ENVIRONMENT: Operating: 0° to 50°C, up to 35°C at <80% RH. Storage: -25°C to 65°C.

EMC: Conforms to European Union Directive 89/336/EEC.

SAFETY: Conforms to European Union Directive 73/23/EEC (meets EN61010-1/IEC 1010).

SERVICES AVAILABLE

7038-3Y-EW	1-year factory warranty extended to 3 years from date of shipment
------------	---

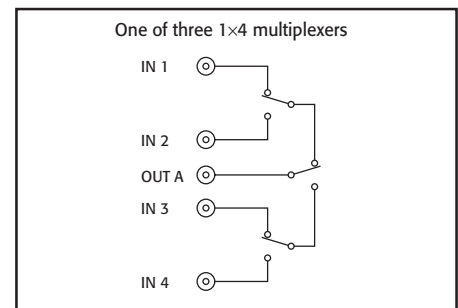

1.888.KEITHLEY (U.S. only)

www.keithley.com

KEITHLEY

A GREATER MEASURE OF CONFIDENCE

7036 7037-D

40-channel Isolated Switch Card 30-channel Digital I/O Card

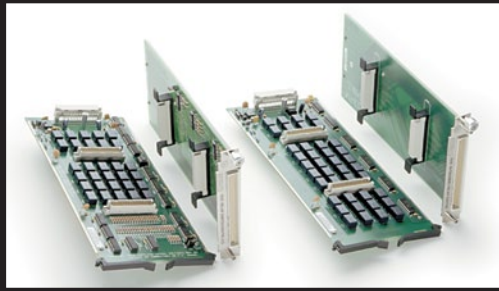

The Model 7036 and 7037-D single-pole relay switching cards are well-suited for configuring automated test systems for portable devices. The Model 7036 offers 40 independent channels of 1-pole Form A switching, while the Model 7037-D provides 30 channels, plus ten independent digital inputs and ten independent digital outputs for control applications. The 7036 provides a 96-pin mass terminated connector. The 7037-D has two heavy duty 50-pin D-sub connectors at the ends of short cables. The D-sub connector version is designed for industrial/production applications where repeated connects/disconnects with external cables are required. The 7037-DT is an extra connector board for the 7037-D card that can be used to upgrade a standard 7037-D to a mass terminated connector.

- Mass terminated connection
- 1A switch rating
- <100pA offset current
- <4μV contact potential

Ordering Information

7036 Single-Pole Relay Card
7037-D Single-Pole Relay Digital I/O Card with D-Sub Connectors

Relay switch configuration for Models 7036 and 7037-D

Each Channel

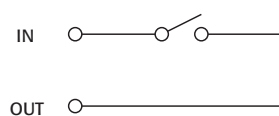

Digital I/O configuration for Model 7037-D

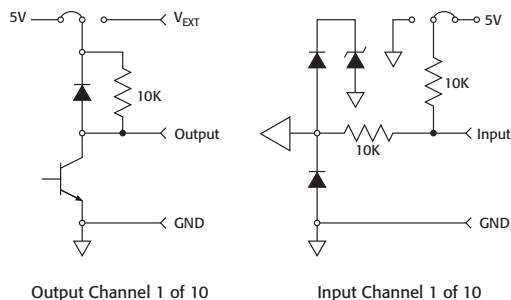

MODEL 7036 SPECIFICATIONS

RELAY SWITCH SPECIFICATIONS

RELAY SWITCH CONFIGURATION: 40 independent channels of 1-pole switching.
CONTACT CONFIGURATION: 1 pole Form A.
CONNECTOR TYPE: 96-pin male DIN card connector.
MAXIMUM SIGNAL LEVEL: 60V DC, 30V rms, 42V peak between any two inputs or chassis, 1A switched, 30VA (resistive load).
CONTACT LIFE: Cold Switching: 10⁸ closures. At Maximum Signal Levels: 10⁵ closures.
CHANNEL RESISTANCE (per conductor): <1Ω.
CONTACT POTENTIAL: <4μV per contact.
OFFSET CURRENT: <100pA.
ACTUATION TIME: 3ms.
ISOLATION: Channel to Channel: >10⁹Ω, <25pF. Common Mode: >10⁹Ω, <100pF.
CROSSTALK (1MHz, 50Ω Load): <-40dB.
INSERTION LOSS (50Ω Source, 50Ω Load): <0.3dB below 1MHz, <3dB below 10MHz.
RELAY DRIVE CURRENT (per relay): 16mA.

7036/7037-D GENERAL

EMC: Conforms to European Union Directive 89/336/EEC.
SAFETY: Conforms to European Union Directive 73/23/EEC (meets EN61010-1/IEC 1010).
ENVIRONMENT: Operating: 0° to 50°C, up to 35°C <80% RH. **Storage:** -25° to 65°C.

ACCESSORIES AVAILABLE

7011-KIT-R 96-pin Female Connector Kit (included)
 7036-MTC-2 Mass Terminated Cable Assembly
 7037-DT Extra Connector Board for the 7037-D Card

SERVICES AVAILABLE

7036-3Y-EW 1-year factory warranty extended to 3 years from date of shipment
 7037-D-3Y-EW 1-year factory warranty extended to 3 years from date of shipment

MODEL 7037-D SPECIFICATIONS

RELAY SWITCH SPECIFICATIONS

RELAY SWITCH CONFIGURATION: 30 independent channels of 1-pole switching.
CONTACT CONFIGURATION: 1 pole Form A.
CONNECTOR TYPE: Cables with 50-pin male and female D-sub connectors.
MAXIMUM SIGNAL: 110V DC, 110V rms, 155V peak between any two inputs or chassis, 1A switched, 30VA (resistive load).
CONTACT LIFE: Cold Switching: 10⁸ closures. At Maximum Signal Levels: 10⁵ closures.
CHANNEL RESISTANCE (per conductor): <1.25Ω.
CONTACT POTENTIAL: <4μV per contact.
OFFSET CURRENT: <100pA.
ACTUATION TIME: 3ms.
ISOLATION: Channel to Channel: >10⁹Ω, <25pF. Common Mode: >10⁹Ω, <100pF.
CROSSTALK (1MHz, 50Ω Load): <-40dB.
INSERTION LOSS (50Ω Source, 50Ω Load): <0.25dB below 1MHz, <3dB below 10MHz.
RELAY DRIVE CURRENT (per relay): 16mA.

DIGITAL I/O SPECIFICATIONS

DIGITAL I/O CAPABILITY: 10 independent inputs. 10 independent outputs.

OUTPUT:

Configuration: 10 open-collector drivers with factory installed 10kΩ pull-up resistors. Each driver has an internal flyback diode.

Pull-Up Voltage: 5V internally supplied, external connection provided for user-supplied voltage up to 42V max. Outputs short circuit protected up to 25V.

Maximum Sink Current:

Per Channel: 250mA. **Per Card:** 1A.

Logic: Hardware user configurable for negative or positive true logic levels.

INPUT:

Configuration: 10 inputs with internal 10kΩ pull-up resistors provided. Input resistors can be set for pull-up or pull-down configuration.

MAXIMUM VOLTAGE LEVEL: 42V peak.

LOGIC: Positive true.

1.888.KEITHLEY (U.S. only)
www.keithley.com

KEITHLEY

A GREATER MEASURE OF CONFIDENCE

Use with 7001 and 7002 switch mainframes

SWITCHING AND CONTROL

7053

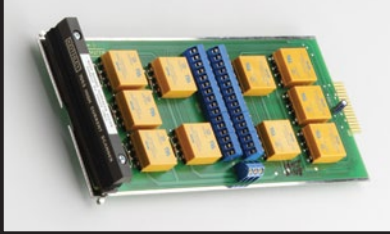

- 5A switching
- 10-channel scanner
- 2-pole Form A
- Maintains current path for unselected channel

Ordering Information

7053 10-channel High Current Scanner with Screw Terminal Connections

7067

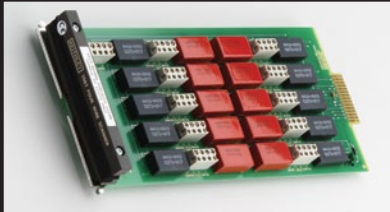

- $1\mu\text{V}$ contact potential
- 4-pole Form A relays
- Quick disconnect screw terminal connections

Ordering Information

7067 4-Wire Scanner Card with Screw Terminal Connections

High Current Scanner Card

10-channel, 2-Pole

The Model 7053 has ten channels and features 5A contacts. The switching is designed to maintain current paths for signals not connected to the output or, when internal jumpers are removed, to provide high input resistance for making voltage measurements. Semiconductor testing, materials research, power supply testing, solar cell measurements, electrochemical applications, and IC testing are among the applications simplified with the Model 7053 High Current Scanner Card.

CHANNELS PER CARD: 10.

CONTACT CONFIGURATION: 2-pole Form A with common guard.

CONNECTOR TYPE: Screw terminal, #18AWG maximum wire size.

RELAY DRIVE CURRENT: 80mA per relay typical.

MAXIMUM SIGNAL LEVEL: 300V, 5A, 100VA (resistive load only).

CONTACT LIFE: $>10^7$ closures cold switching; $>10^5$ closures at maximum signal levels.

CONTACT RESISTANCE: $<0.15\Omega$ to rated life.

CONTACT POTENTIAL: $<1\text{mV}$.

ACTUATION TIME: $<15\text{ms}$, exclusive of mainframe.

CHANNEL ISOLATION: $>10^6\Omega$, $<50\text{pF}$.

INPUT ISOLATION: $>10^7\Omega$, $<150\text{pF}$.

COMMON MODE VOLTAGE: 300V peak.

EMC: Conforms to European Union Directive 89/336/EEC.

SAFETY: Conforms to European Union Directive 73/23/EEC (meets EN61010-1/IEC 1010).

OPERATING ENVIRONMENT: 0° to 50°C , up to 35°C at 70% RH.

STORAGE ENVIRONMENT: -25°C to 65°C .

SERVICES AVAILABLE

7053-3Y-EW 1-year factory warranty extended to 3 years from date of shipment

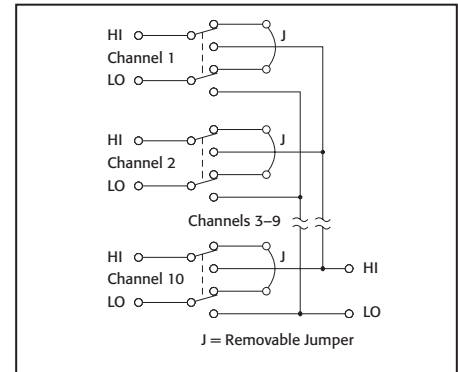

4-Wire Scanner Card

10-channel

Four-wire or Kelvin connections are generally made to minimize errors created by I-R drops in the cabling and interconnects of a test system. Each channel of the Model 7067 has two general-purpose source contacts that switch currents up to 350mA, as well as two high quality contacts ($<1\mu\text{V}$ contact potential) for dry switching of voltage to the sensing circuit. The Model 7067 is well-suited to precision resistance measurements as required in temperature coefficient testing. Other applications include remote sensing of voltage source outputs and bridge measurements.

CHANNELS PER CARD: 10.

CONTACT CONFIGURATION: 4-pole Form A, common shield connection.

RELAY DRIVE CURRENT: 35mA per channel typical.

SENSE LINES:

Maximum Signal Level: 150V, 100mA, 2VA (resistive loads only).

Contact Resistance: $<0.5\Omega$ initial, 2Ω to rated life.

Contact Potential: $<1\mu\text{V}$ per contact pair with copper leads (<5 minutes after actuation).

SOURCE LINES:

Maximum Signal Level: 150V, 350mA, 10VA (resistive loads only).

Contact Resistance: $<0.2\Omega$ initial, 2Ω to rated life.

Contact Potential: $<100\mu\text{V}$ per contact pair.

CONNECTOR TYPE: Quick disconnect screw terminal, #18AWG maximum wire size.

CONTACT LIFE: $>10^8$ closures at dry circuit; $>10^6$ closures at maximum signal levels.

WARM-UP: 1 hour for thermal stability.

ACTUATION TIME: $<2\text{ms}$, exclusive of mainframe.

CHANNEL ISOLATION: $>10^6\Omega$, $<10\text{pF}$.

INPUT ISOLATION, DIFFERENTIAL: $>10^6\Omega$, $<50\text{pF}$.

COMMON MODE VOLTAGE: $<150\text{V}$ peak.

OPERATING ENVIRONMENT: 0° to 50°C , up to 35°C at 70% R.H.

STORAGE ENVIRONMENT: -25°C to 65°C .

APPLICATIONS: 4-wire resistance (resistors, relays, connectors, switches, RTDs). External sensing on voltage sources. DUT in/out switching (potentiometers, isolation amplifiers, strain gages).

SERVICES AVAILABLE

7067-3Y-EW 1-year factory warranty extended to 3 years from date of shipment

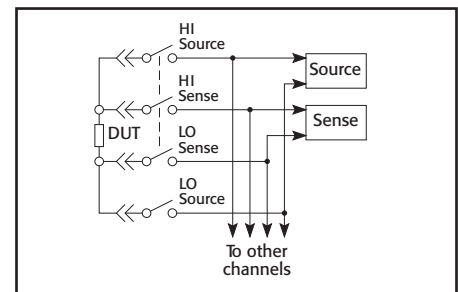

1.888.KEITHLEY (U.S. only)
www.keithley.com

KEITHLEY

A GREATER MEASURE OF CONFIDENCE

7065

Hall Effect Card

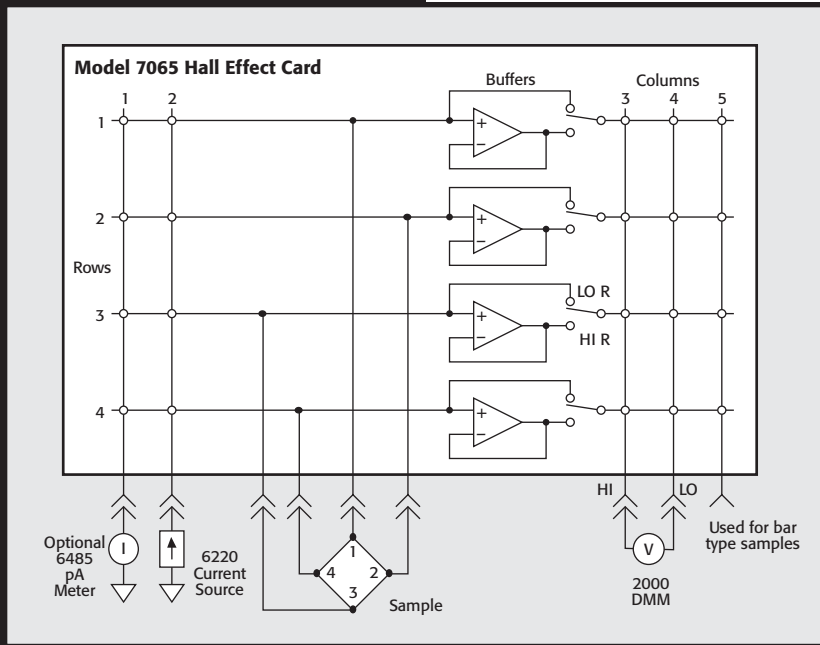

Building blocks for an economical measurement system

The Model 7065 Hall Effect Card is intended for those who want to assemble their own economical Hall test systems. It also can form the foundation of a Hall Effect system. The sensitivity and capabilities of this card are unmatched by any other system or Hall Effect electronics package.

The Model 7065 is a signal conditioning card designed to buffer test signals from the Hall sample to the measurement instrumentation and to switch current from a source to the Hall sample. When used with Keithley's Model 7001 scanner mainframe, the Model 7065 provides the switching capability to measure Hall voltages as low as 50nV and sample resistances in excess of $10^{12}\Omega$.

All the accessories needed to connect the sample holder, scanner, instruments, and controller are included, simplifying connections. The Model 7065 is connected directly to the sample, and all instruments are connected via the IEEE-488 bus to the controller. Examples of resistivity and Hall voltage measurement programs are included in the Model 7065 Instruction Manual.

Ordering Information

7065 Hall Effect Card
7001 Switch System

The Model 7065 can be operated in either a low resistivity or a high resistivity mode. In the high resistivity mode, input impedance is greater than $100T\Omega$, input bias current is less than 150fA, and output resistance is less than 60Ω . Input voltage ranges in both operating modes is +8V to -8V. If higher voltage is desired, Keithley recommends using a 6220/6514 system. Cabling and sample connections must be carefully designed to make full use of the Model 7065's capabilities. Refer to Keithley's Low Level Measurements handbook for guidance in designing these connections.

ACCESSORIES SUPPLIED

4801	Low Noise Input Cable
7078-TRX-10	3-slot Triax Cable (10 ft.)
6172	2-slot Male to 3-Lug Female Triax Adapter
7025-10	Triaxial Input Cable (10 ft.) (4 supplied)
4851	BNC Shorting Plug
Wire Kit Including:	
SC-72-0	Single Conductor Insulated Wire, black (4 ft.) (2 supplied)
SC-72-9	Single Conductor Insulated Wire, white (4 ft.)
BG-5	Single Banana Plug, black (2 supplied)
BG-10-1	Single Banana Plug, white
BG-7	Double Banana Plug, black
SC-8	2-conductor Cable w/shield (10 ft.)
7007-2	Double Shielded Premium Cable (6 ft.)

SERVICES AVAILABLE

7065-3Y-EW	1-year factory warranty extended to 3 years from date of shipment
------------	---

LOW RESISTIVITY MODE

INPUT VOLTAGE OPERATING RANGE: +8 to -8V.
INPUT IMPEDANCE: $>100G\Omega$ in parallel with $<420pF$.
INPUT BIAS CURRENT: $<100pA$.
INPUT VOLTAGE NOISE: $<50nV$ p-p, 0.1 to 10Hz bandwidth.
INPUT TO OUTPUT RESISTANCE: $<30\Omega$.

HIGH RESISTIVITY MODE

INPUT VOLTAGE OPERATING RANGE: +8 to -8V.
INPUT IMPEDANCE: $>100T\Omega$ in parallel with $<3pF$.
INPUT BIAS CURRENT: $<150fA$ at 23°C. Doubles approximately every 10°C rise in ambient room temperature.
INPUT VOLTAGE NOISE: $<10\mu V$ p-p, 0.1 to 10Hz bandwidth.
OUTPUT RESISTANCE: $<60\Omega$.

CONFIGURATION

Input characteristics and output matrix configuration for van der Pauw or Hall bar measurements. Input characteristics selectable for either low resistivity or high resistivity samples.

GENERAL

MAXIMUM COMMON MODE VOLTAGE (analog ground to earth ground): 30V peak, DC to 60Hz sine wave.
ISOLATION: Analog ground to earth ground: $>10^9\Omega$ in parallel with 150pF.
WARM-UP: 1 hour to rated specifications.
ENVIRONMENT: Operating: 0°-35°C, up to 70% R.H.
Storage: -25° to +65°C.
CONNECTORS:
Current Source Input: Two-lug female triaxial. Input HI to LO clamped at $\pm 12V$. **Maximum Input:** 100mA.
Sample Inputs: Four two-lug female triaxial. Outer shell is analog ground. Inner shield is driven guard. **Maximum Input Overload (HI to analog ground or GUARD to analog ground):** $\pm 12V$.
Current Monitor Output: Insulated female BNC.
Measurement Outputs: Spring-loaded terminals. Accepts AWG #18 to #24 wire. **Maximum Load:** 1mA.
DIMENSIONS, WEIGHT: 32mm high \times 114mm wide \times 272mm long (1 in \times 4 in \times 10 in). Net weight: 434kg (15½ oz).
All specifications are 1 year, 0°-35°C, installed in scanner mainframe.

The foundation of a Hall Effect system

SWITCHING AND CONTROL

1.888.KEITHLEY (U.S. only)

www.keithley.com

KEITHLEY

A GREATER MEASURE OF CONFIDENCE

7090

Optical Switch Cards

Use with 7001 and 7002 scanner mainframes.

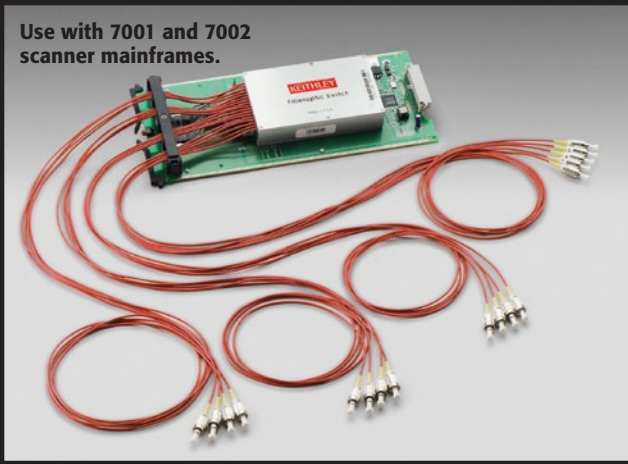

- Perform multiple tests on a single device without changing test setup
- Test multiple devices with a single instrument
- 1×8 and 1×16 optical switching cards
- Single-mode or multimode fiber
- Very low insertion loss, 0.6dB typ.
- 0.03dB repeatability
- FC/SPC connectors
- Bulkhead options available

Ordering Information

7090-8-4 1×8 Multimode with FC/SPC Fiber Pigtail

7090-16-6 1×16 Single-mode with FC/SPC Fiber Pigtail

Accessories Supplied
User's Manual

The Model 7090 Optical Switch Cards are designed for the Model 7001 and 7002 Switch Mainframes. These cards simplify making accurate connections from one input fiber channel to either eight or sixteen output fiber channels. When combined with existing Series 7001/7002 switch cards, these optical switches allow for hybrid switching combinations of optical, RF, and DC switching within a single switch mainframe, extending the automated testing environment.

Combine Optical, DC, and RF Switching in One Instrument

The Model 7090 cards are compatible with all other Series 7001/7002 switch cards, so they can be used in conjunction with DC switch cards to control an L-I-V test system as well as for RF switching needs. All of the switches can be used in one mainframe with a single GPIB address.

Meets a Range of Test Requirements

Model 7090 cards offer a number of options to ensure the compatibility of the switch with the test setup. Each switch card has one input fiber aligned to one of eight or sixteen output fibers. Depending on the card chosen, the fiber is either a 9 μ m single-mode fiber or 62.5 μ m multimode fiber. The

input and output fiber channels are available with several connection options, including FC/SPC and a one-meter fiber pigtail with a connector. For a complete list of available features, see the Physical Properties Guide below.

Faster Test Development

Several built-in features of the Model 7001 and 7002 mainframes simplify system setup, operation, and modifications. All aspects of the instrument can be programmed from either the mainframe's front panel or over the IEEE bus. Both mainframes offer Trigger Link interfaces to ensure tight control over the test system and eliminate IEEE bus command overhead.

SERVICES AVAILABLE

7090-8-4-3Y-EW 1-year factory warranty extended to 3 years from date of shipment

7090-16-6-3Y-EW 1-year factory warranty extended to 3 years from date of shipment

APPLICATIONS

Production testing of:

- Laser diode modules
- Chip on submount laser diodes
- Laser diode bars
- LEDs and OLEDs
- Passive optical components
- VCSEL arrays
- Optical add/drop multiplexer (OADM)

PHYSICAL PROPERTIES

CONFIGURATION: Single channel, 1×N non-blocking switch.

Model Number	No. of Channels	Fiber Type	Wavelength (nm)	Connector	Fiber Length
7090-8-4	1×8	Multimode fiber 62.5/125 each ch.	780-1350	FC/SPC	1m
7090-16-6	1×16	Single-mode fiber (SMF-28) 9/125 each ch.	1290-1650	FC/SPC	1m

1.888.KEITHLEY (U.S. only)

www.keithley.com

KEITHLEY

A GREATER MEASURE OF CONFIDENCE

7152

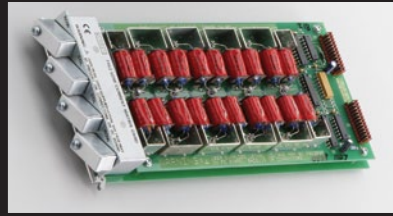

- Sub-pA offset current
- Easy interconnect and expansion
- Maximum signal 200V and 1A
- Standard mass terminated cable accessories

Ordering Information

7152 **4x5 Low Current Matrix Card**

Accessories Supplied
Connector caps

7153

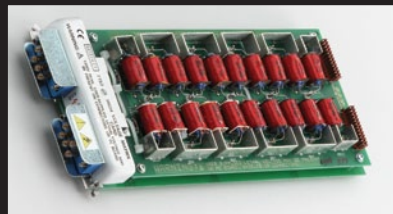

- 1300V switching
- Sub-pA offset current
- 2-pole switching
- Mass termination connectors

Ordering Information

7153 **4x5 High Voltage Low Current Matrix Card**

4x5 Low Current Matrix Card

The Model 7152 is an ideal solution for small to moderate-size matrix systems that require superior performance in DC isolation for measurements of semiconductor parameters and insulating properties of materials. Offset current is <1pA with path isolation >10¹³Ω. Each matrix crosspoint is a two-pole relay with the ability to switch both signal and guard.

Interconnect, expansion of the matrix, and connection to instruments and devices are easily accomplished using two standard interconnect cable assemblies. The 7152-MTC cables are terminated at both ends with M-series connector blocks for quick expansion between cards and connection to 7152-MTR bulkhead receptacles. 7152-TRX cables are terminated at one end with M-series connectors and at the other end with 3-lug triaxial connector shells for direct connection to electrometers and SMUs.

MATRIX CONFIGURATION: 4 rows by 5 columns.
CROSSPOINT CONFIGURATION: 2-pole Form A (Signal and Guard).
RELAY DRIVE CURRENT: 20mA (per crosspoint).
PEAK CONTACT RATING: 200V, 1A carry/0.5A switched. 10VA (resistive load).
PEAK VOLTAGE: **Common Mode:** 200V (Signal or Guard to Chassis). **Path-Path:** 200V (Signal or Guard to Signal or Guard).

CONTACT LIFE: 10⁸ closures (cold switching), 10⁵ closures (at maximum signal level).
ACTUATION TIME: <2ms exclusive of mainframe.
ISOLATION: Path: >10¹³Ω and <1pF. **Differential:** >10¹¹Ω and <100pF. **Common Mode:** >10⁹Ω and <300pF.
CROSSTALK: <-50dB at 1MHz, 50Ω load.
INSERTION LOSS: 0.1dB typical (1MHz, 50Ω source, 50Ω load).
3dB BANDWIDTH: 60MHz typical (50Ω load).
OFFSET CURRENT: <1pA (10fA typical).
CONTACT POTENTIAL: 20μV per contact typical.

ACCESSORIES AVAILABLE

PRE-BUILT CABLES

7152-MTC-2	Low Noise M-Series to M-Series Cable, 2 ft.
7152-MTC-10	Low Noise M-Series to M-Series Cable, 10 ft.
7152-TRX-10	Low Noise M-Series to Triax Cable, 10 ft.

M-SERIES BULKHEAD CONNECTORS

7152-KIT	M-Series Plug for custom wiring
7152-MTR	M-Series Receptacle for 7152-MTC-* Cables and 7152-KIT Plug

REQUIRED TOOLS FOR BULKHEAD CONNECTORS

7074-CIT	Extraction Tool for 7152-KIT and 7152-MTR shield contacts
7074-HCT	Hand Crimp Tool for 7152-KIT and 7152-MTR shield contacts
7152-HCT	Hand Crimp Tool for 7152-KIT and 7152-MTR coaxial contacts

SERVICES AVAILABLE

7152-3Y-EW	1-year factory warranty extended to 3 years from date of shipment
------------	---

4x5 Low Current Matrix Card

High Voltage

The Model 7153 is designed to switch low level, high voltage, and high impedance signals for applications such as parametric tests on semiconductor devices. The 7153 allows signal levels up to 1300V while maintaining offset current of <1pA (typically 10fA) and path isolation >10¹³Ω. Each crosspoint is a 2-pole relay to switch both signal and guard. Interconnect between the matrix and instruments such as the Model 237 SMU is done with the 7153-TRX cable. This cable has an M-series connector for the matrix and five 3-slot male triax connectors at the opposite end. The cable will mate with the row or column connectors of the Model 7153.

MATRIX CONFIGURATION: 4 rows by 5 columns.
CROSSPOINT CONFIGURATION: 2-pole Form A (Signal and Guard).
CONNECTOR TYPE: Miniature coax, M-series plug.
RELAY DRIVE CURRENT: 40mA (per crosspoint).
MAXIMUM SIGNAL LEVEL: 1300V between any 2 signal pins or chassis; 200V between Signal and Guard. 1A carry/0.5A switched. 10VA peak (resistive load).
CONTACT LIFE: 10⁸ closures (cold switching), 10⁵ closures (at maximum signal level).
PATH RESISTANCE: <1Ω per contact to rated life.
ACTUATION TIME: <2ms exclusive of mainframe.
ISOLATION: Path: >10¹³Ω and <1pF. **Differential:** >10¹¹Ω and <100pF. **Common Mode:** >10⁹Ω and <300pF.

CROSSTALK: <-50dB at 1MHz, 50Ω load.
INSERTION LOSS: 0.1dB typical (1MHz, 50Ω source, 50Ω load).
3dB BANDWIDTH: 60MHz typical (50Ω load).
OFFSET CURRENT: <1pA (10fA typical).
CONTACT POTENTIAL: <50μV typical.

ACCESSORIES AVAILABLE

7153-TRX	Low Noise M-Series to Triax Cable, 5 ft.
----------	--

SERVICES AVAILABLE

7153-3Y-EW	1-year factory warranty extended to 3 years from date of shipment
------------	---

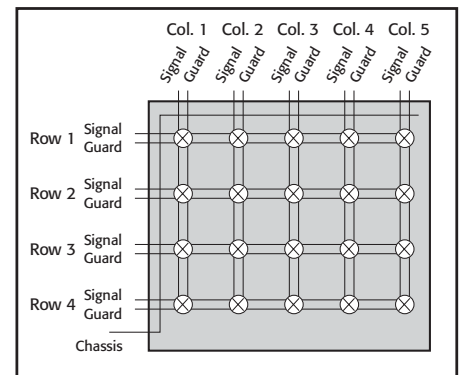

Use with 7001 and 7002 switch mainframes

SWITCHING AND CONTROL

7154

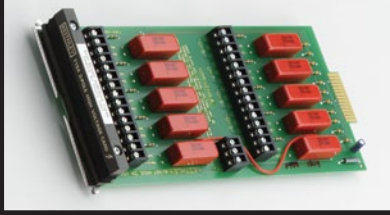

- 1100 volts peak
- 2-pole switching
- High and low fused

Ordering Information

7154 High Voltage Scanner Card

7158

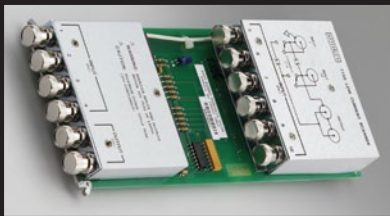

- Sub-picoamp offset current
- Maintains current path for unselected channel
- BNC connectors

Ordering Information

7158 Low Current Scanner Card

Accessories Supplied

4801 Low Noise Male to Male BNC Input Cable

High Voltage Scanner Card

10-channel

The Model 7154 switches voltages to 1100V peak or currents to 0.5A. The current carry capacity of each relay contact is 1A. Two-pole relays switch both circuit High and Low for full floating measurements and each input line is fuse protected against current overload. A Guard input common to all channels is provided for shielding or as a Guard driven from a single instrument. Guards may be isolated by removing jumpers installed at each input. Multiple switched guard circuits can be achieved by removing the jumper and connecting circuit Guard to the Low input terminal.

CHANNELS PER CARD: 10.

CONTACT CONFIGURATION: 2-pole Form A with user-selectable shield or driven Guard. Each pole is fused using #38AWG magnet wire.

CONNECTOR TYPE: Screw terminals, #16AWG maximum wire size.

RELAY DRIVE CURRENT: 57mA per relay typical.

MAXIMUM SIGNAL LEVEL: 1100V peak, 0.5A DC or rms switched, 1A DC or rms carry, 10W.

CONTACT LIFE: >10⁶ closures (cold switching); >5×10⁶ closures (at maximum signal level).

CONTACT RESISTANCE: <200mΩ initial, 2Ω to rated life.

CONTACT POTENTIAL: <35μV per contact pair with copper leads.

ACTUATION TIME: <2ms exclusive of mainframe.

CHANNEL ISOLATION: 10¹⁰Ω, <10pF.

INPUT ISOLATION: Differential: >10⁹Ω, <10pF.

Common Mode: >10⁹Ω, <150pF.

COMMON MODE VOLTAGE: 1100V peak.

ENVIRONMENT: Operating: 0° to 50° up to 35°C at 70% R.H.
Storage: -5° to +65°C.

SERVICES AVAILABLE

7154-3Y-EW 1-year factory warranty extended to 3 years from date of shipment

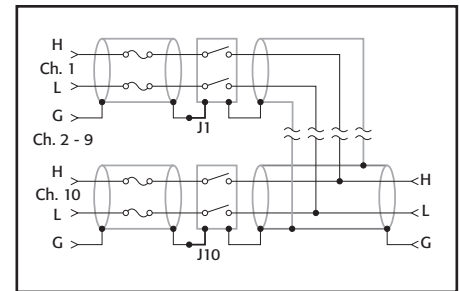

Low Current Scanner Card

10-channel

The Model 7158 provides quality low-current switching at an affordable price. The offset current error generated is specified <1pA, with typical performance at <30fA. When used with a voltage source and electrometer or picoammeter, this card can easily automate insulation resistance tests, reverse leakage tests on semiconductor junctions, or gate leakage tests on FETs.

The Model 7158 is designed to maintain the current path even when the channel is deselected. Input connectors are BNC for shielding of the sensitive measurements and for compatibility with low noise coaxial cables such as Keithley accessory cables Models 4801 and 4803. Two outputs are provided to allow for chaining several scanner cards to one measurement instrument, and an isolation relay in the output HI minimizes interaction between cards.

CHANNELS PER CARD: 10.

CONTACT CONFIGURATION: Single pole, simultaneous break and make for signal HI input. Signal LO is common for all 10 channels and output. When a channel is off, signal HI is connected to signal LO.

CONNECTOR TYPE: BNC.

RELAY DRIVE CURRENT: 100mA per card typical (regardless of channel closures selected).

MAXIMUM SIGNAL LEVEL: 30V, 100mA peak (resistive load).

CONTACT LIFE: >10⁶ closures at maximum signal levels; >10⁷ closures at low signal levels.

CONTACT RESISTANCE: <1Ω.

CONTACT POTENTIAL: <200μV.

OFFSET CURRENT: <1pA (<30fA typical).

3dB BANDWIDTH: 1MHz typical.

ACTUATION TIME: <1ms, exclusive of mainframe.

CHANNEL ISOLATION: >10¹⁴Ω.

INPUT ISOLATION: Differential: >10⁹Ω, <50pF.

Common Mode: >10⁹Ω, <150pF.

COMMON MODE VOLTAGE: <30V maximum.

ACCESSORIES AVAILABLE

4801 Low Noise Male to Male BNC Input Cable
4802-10 Low Noise BNC to Unterminated Cable, 10 ft.
4803 Low Noise BNC Cable Kit for 7158

SERVICES AVAILABLE

7158-3Y-EW 1-year factory warranty extended to 3 years from date of shipment

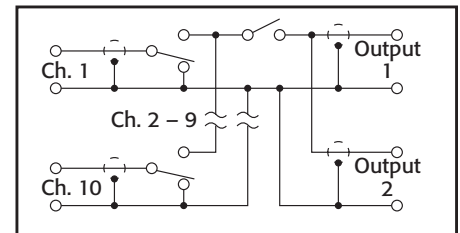

1.888.KEITHLEY (U.S. only)
www.keithley.com

KEITHLEY

A GREATER MEASURE OF CONFIDENCE

7168



- <30nV contact potential
- Bare copper terminal connections

Ordering Information

7168 8-channel Nanovolt Scanner Card

Nanovolt Scanner Card

8-channel, 2-pole

The Model 7168 is an 8-channel, 2-pole card with <30nV of thermal offset. It will switch any one of eight signals to one output in less than 3ms. Channel offset leakage current is <50pA at 23°C. When the 7168 is used with the Model 2182A, the noise and drift performance of the 2182A is not degraded.

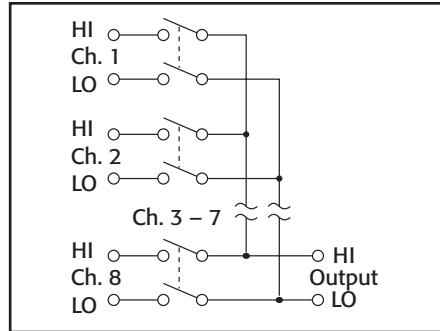

CHANNELS PER CARD: 8.

CONFIGURATION: Two poles per channel, input HI and LO.

CONNECTOR TYPE: Screw terminal to bare copper printed circuit pad.

MAX. SIGNAL LEVEL: 10V, 50mA peak (resistive load only).

CONTACT RESISTANCE: <12Ω.

CONTACT POTENTIAL (HI to LO) BETWEEN CHANNELS: <30nV when properly zeroed with supplied leads (see manual for recommended procedure). Typically <60nV without zeroing.

CONTACT TYPE: Solid state JFET switch.

ACTUATION TIME: <3ms, exclusive of mainframe.

INPUT LEAKAGE: <50pA per channel at 23°C.

INPUT ISOLATION: >10⁹Ω, <40pF between any input terminals or between any input terminal and earth.

COMMON MODE VOLTAGE: 30V peak.

MAXIMUM VOLTAGE BETWEEN ANY TWO TERMINALS: 10V.

WARM-UP: 2 hours in mainframe for thermal stability.

OPERATING ENVIRONMENT: 0°–40°C; up to 35°C at 70% R.H.

STORAGE ENVIRONMENT: –25° to 60°C.

ACCESSORIES SUPPLIED

2107-4	Low Thermal Input Cable for 2182A (1 supplied)
7168-316	Low Thermal Input Cables for 7166 (8 supplied)

SERVICES AVAILABLE

7168-3Y-EW	1-year factory warranty extended to 3 years from date of shipment
------------	---

Use with 7001 and 7002 switch mainframes

SWITCHING AND CONTROL

1.888.KEITHLEY (U.S. only)

www.keithley.com

KEITHLEY

A GREATER MEASURE OF CONFIDENCE

707B 708B

- Significantly faster command-to-connect speeds than earlier Series 700 mainframes
- 708B mainframe controls a single 8×12 matrix card
- 707B mainframe controls up to six 8×12 matrix cards
- Compatible with the popular plug-in cards designed for the 707A/708A mainframes
- Support for both remote (via LXI, USB, and GPIB interfaces) and manual (via front panel) programming
- Integrates seamlessly with the Model 4200-SCS for semiconductor I-V and C-V characterization via GPIB interface
- Stores hundreds of switching configurations and channel patterns in non-volatile memory for reuse
- LXI Class C interface supports remote programming and control
- Embedded TSP® processor and TSP-Link® interface make it easy to integrate Series 2600A System SourceMeter® instruments into a high speed, self-contained tester
- 14 bits of digital I/O

APPLICATIONS

- Support for semiconductor device characterization and process control monitoring
- Fully automated testing of a wide range of electronic components in both lab and production environments

Semiconductor Switch Matrix Mainframes Six-slot and Single-slot Versions



Model 707B Six-slot Semiconductor Switch Matrix Mainframe

The six-slot Model 707B and single-slot Model 708B Semiconductor Switch Matrix Mainframes extend Keithley's decades-long commitment to innovation in switch systems optimized for semiconductor test applications. These mainframes build upon the strengths of their popular predecessors, the Models 707/707A and 708/708A, adding new features and capabilities designed to speed and simplify system integration and test development. New control options and interfaces offer system builders even greater flexibility when configuring high performance switching systems for use in both lab and production environments. Just as important, both new mainframes are compatible with the popular switch cards developed for the Models 707A and 708A, simplifying and minimizing the cost of switch system migration.

Faster Command-to-Connect

High performance Model 707B and 708B semiconductor switch matrix mainframes slash the time from command to connection, offering significantly faster test sequences and overall system throughput than Keithley's earlier 707A and 708A mainframes.



Model 708B Single-slot Semiconductor Switch Matrix Mainframe

1.888.KEITHLEY (U.S. only)

www.keithley.com

KEITHLEY

A GREATER MEASURE OF CONFIDENCE

707B 708B

Ordering Information

707B	Six-slot semiconductor switch mainframe
708B	Single-slot semiconductor switch mainframe

Extended warranty, service, and calibration contracts are available.

Accessories Supplied

Product Information CD-ROM:

- Product Information CD
- Quick Start Guide
- Switching and Control Product Information CD
- Test Script Builder User Suite CD

CA-180-4A: CAT 5 Ethernet Crossover Cable, 1m (3.3 ft)

CA-179-2A: CAT 5 Ethernet Cable, 3m (10 ft)

CO-7: Line Cord

Rear Fixed Rack Mount Hardware (707B only)

ACCESSORIES AVAILABLE

CA-126-7A	25-pin Female Digital I/O to 25-pin Male Cable, 3m (10 ft)
2600-TLINK	Digital I/O to Trigger Link Cable, 1m (3.3 ft)
4299-6	Universal Full Rack Mount Kit (for Model 708B)
7007-1	Double-shielded GPIB Cable, 1m (3.3 ft)
7007-2	Double-shielded GPIB Cable, 2m (6.6 ft)
7072	Semiconductor Matrix Card
7072-HV	High Voltage Semiconductor Matrix Card
7072-TRT	Triax Fastening Tool
7079	Rear Slide Rack Mount Kit (for Model 707B)
7173-50	High Frequency, 2-pole, 4×12 Matrix Card
7174A	Low Current Matrix Card

SOFTWARE

IVI-COM and IVI-C Driver for C#, VB.NET, Visual C++, VB6, and LabWindows/CVI
 LabVIEW® Driver
 Example TSP® Scripts
 Test Script Builder

SERVICES AVAILABLE

707B-3Y-EW	1-year Factory Warranty Extended to 3 Years from date of shipment
707B-5Y-EW	1-year Factory Warranty Extended to 5 Years from date of shipment
708B-3Y-EW	1-year Factory Warranty Extended to 3 Years from date of shipment
708B-5Y-EW	1-year Factory Warranty Extended to 5 Years from date of shipment

1.888.KEITHLEY (U.S. only)

www.keithley.com

Semiconductor Switch Matrix Mainframes

Six-slot and Single-slot Versions

Optimized for Easy Integration with Existing Test Systems

To minimize migration issues for current users of Model 707A and 708A mainframes, the Model 707B and 708B are designed for command emulation with Models 707A and 708A. The 707B and 708B also support the popular switch matrix cards developed for the Model 707A and 708A, so there's no need to purchase new cards to take advantage of the new mainframes:

- Model 7174A Low Current Matrix Card:** This 8×12 card is designed for semiconductor research, development, and production applications that demand high quality switching of I-V and C-V signals. Its low leakage and minimal dielectric absorption ensure that key device measurements can be performed many times faster than with earlier switching technologies. Its superior low current performance makes it ideal for use with both Models 2635A and 2636A System SourceMeter Instruments for adding high speed I-V source and measurement capabilities and for accessing the I-V and C-V measurement capabilities of the Model 4200-SCS parametric analyzer.
- Model 7072 Semiconductor Matrix Card:** This 8×12 switch supports the low level and high impedance measurements encountered in semiconductor parametric tests on wafers and devices. It provides two low current paths with just 1pA maximum offset current for sensitive sub-picoamp measurements, and two other paths optimized for measuring C-V characteristics from DC to 1MHz. Four more high quality signal paths with <20pA offset current provide for general-purpose signal switching up to 100nA or 200V.
- Model 7072-HV High Voltage Semiconductor Matrix Card:** Like the Model 7072, the 7072-HV is designed to handle low level, high voltage, and high impedance signals. It provides two signal paths capable of switching 1300V with less than 1pA of offset current, so it's ideal for switching the high voltage signals encountered in breakdown measurements or oxide integrity testing. Two paths are optimized for C-V measurements from DC to 1MHz or for switching low currents with a common ground. Four additional high quality signal paths with less than 20pA offset current provide for signal switching to 200V.
- Model 7173-50 High Frequency, 2-pole, 4×12 Matrix Card:** The Model 7173-50 provides 200MHz bandwidth and a rise time of <2ns. Offset voltage is <15µV per crosspoint, and offset current is <200pA. Its combined AC and DC capabilities make it ideal for mixed-signal applications, such as testing ADCs or DACs, which involve measuring both digital and analog signals.

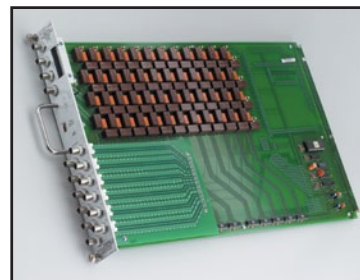
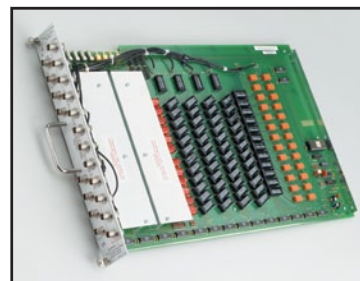
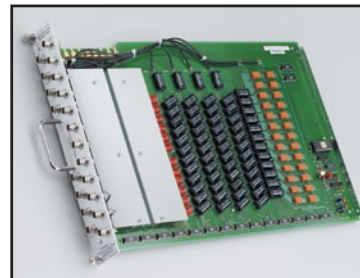

For additional details and specifications on these cards, refer to their individual data sheets, available on www.keithley.com. A Keithley applications engineer or representative can help you choose the most appropriate card or cards for a specific application.

707B 708B

Semiconductor Switch Matrix Mainframes Six-slot and Single-slot Versions

In addition, the Models 707B and 708B offer a number of features to ensure their compatibility with Keithley instrumentation already at work in labs and on test floors around the world. For example, these semiconductor switch matrix mainframes are compatible with the Model 4200-SCS semiconductor parametric analyzer's existing matrix driver and GPIB interface, which allows them to become drop-in switch matrix replacements for many applications. The new mainframes also provide electrical performance that correlates closely with that of the Model 707A and Model 7174A switch card, the previous industry-standard switching solution.

Suited for Both Lab and Fab

Like their predecessors, the Models 707B/708B are specifically designed for the requirements of both semiconductor lab and production test environments, delivering ultra low current switching performance using standard triax connectors and cables. For automating smaller test systems with a limited number of pins and instruments, the Model 708B supports a single switch card with up to 8 rows and 12 columns (8×12). For applications requiring higher switch counts, the Model 707B can accommodate up to six 8×12 cards, which can be connected via an internal backplane or jumpers to form larger matrices. Both mainframes also support mixed signal switching for both DC and RF (up to 200MHz) signals.

Choice of Manual Operation or Remote Programming

Both mainframes offer a variety of manual operation and remote programming functions via either the front panel controls or a choice of interfaces. For example, for manual operation, such as when

Advantages of TSP® Technology for Switch Throughput

The test script processor (TSP) technology embedded in these upgraded mainframes allows for distributed processing and control rather than relying exclusively on a central PC to direct their operation, increasing test speed and lowering overall test cost. The TSP is a full-featured test sequence engine that allows unprecedented control of the test sequence. In addition to responding to individual ICL commands, it can store a user-defined test script or sequence in memory and execute it on command, which limits the set-up and configuration time for each step in the test sequence and increases throughput by decreasing communication time.

Test scripts are complete test programs based on Lua, an easy-to-use but highly efficient and compact scripting language. Because test scripts can contain any sequence of routines that are executable by conventional programming languages (including decision-making algorithms and control of the digital I/O), the mainframe can manage the operation of entire tests without sending readings back to a PC for use in decision making. The TSP can even access the mainframe's 14-bit digital I/O on the fly, increasing throughput by allowing instrument and binning equipment such as handlers to run without PC interference. This eliminates delays due to GPIB traffic congestion and greatly improves overall test times.

TSP control allows individual switches and instruments or groups of them to operate autonomously, often eliminating the need for a high-level PC system controller altogether. This same proven TSP technology has already been successfully incorporated into Keithley's innovative Series 2600A System SourceMeter instruments and Series 3700A Multimeter/Switch System.



The 707B or 708B can be easily used as a drop-in replacement for the 707A or 708A in a test system based on the Model 4200-SCS semiconductor parameter analyzer.

707B 708B

Semiconductor Switch Matrix Mainframes Six-slot and Single-slot Versions

experimenting with a new switching configuration, the updated front panel interface allows labeling switch card rows (instruments) and columns (pins) alphanumerically, which simplifies keeping track of what's connected to each crosspoint. An LED crosspoint display makes it easy to identify whether a specific channel is open or closed, as well as to determine which slots are occupied and which cards are currently in use. A two-line display shows both error messages and user-defined messages, and displays control menus and open/closed channel messages.

An intuitive navigation/control knob allows scrolling through and opening/closing channels. Key pad controls support scrolling through menus, changing host interface settings, saving and restoring instrument setups, and loading and running factory and user-defined test scripts, etc.

Test system integrators can choose from several instrument communication interfaces and tools for remote programming and control of the Model 707B or 708B:

- TSP-Link® is a high speed system expansion and coordination interface that simplifies linking instruments and switches for faster inter-unit communication and control. It provides a high speed, low latency interface to other TSP (Test Script Processor)-based hardware, enabling simple multi-box and multi-instrument software control, as well as simplified test system scaling as new requirements evolve.

With TSP-Link, there's no need to add external triggers and remote communication cables to individual units because all TSP-Link connected devices can be controlled from a single master unit. Up to 16 Model 707B/708B chassis can be linked together to form a larger switching matrix using TSP-Link. Each mainframe has two TSP-Link connectors to facilitate chaining instruments together. They can also be used to connect Model 707B/708B semiconductor switch matrix mainframes to other TSP-Link enabled instruments, such as Keithley's Series 2600A System SourceMeter instruments. Every piece of instrumentation connected via TSP-Link can be controlled by a single master unit, just as though they were all housed in the same chassis.

- Like all instruments compliant with the LXI (LAN eXtensions for Instrumentation) standard, the Models 707B and 708B have a built-in switch control Web page that is accessible via any standard Web browser. In conjunction with a 10/100M Base-T Ethernet connection and LAN-based triggering, this Web interface offers a quick and easy method to program switching patterns. Interactive schematics of each card in the mainframe support point-and-click control for opening and closing switches. A scan list builder is provided to guide users through the requirements of a scan list (such as trigger and looping definitions) for more advanced applications. The Web page's point-and-click design provides easy switch system control, as well as basic switch system troubleshooting and diagnostics capabilities.

TSB (Test Script Builder) Embedded is an application with a reduced feature set that resides in the mainframe and can be accessed through its web page. Like the full Test Script Builder programming tool, it offers script-building functions and can be used to run example scripts provided with the mainframe. It also includes a command line interface that can be used to issue single-line ICL commands.

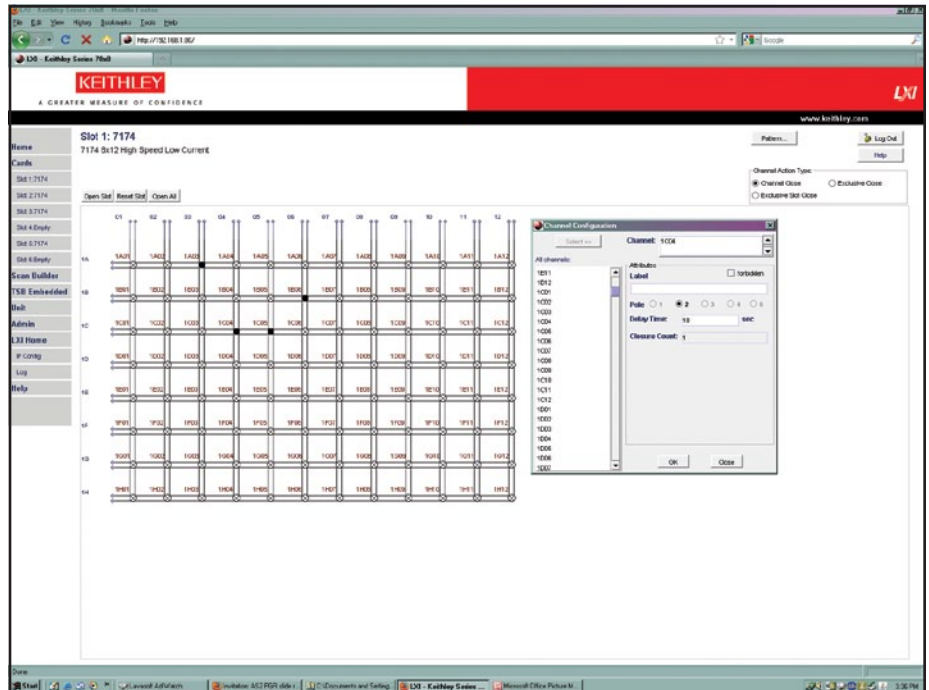

The Models 707B and 708B include a built-in Web interface that offers a quick and easy method to control the instrument remotely. Interactive schematics of each card in the mainframe support point-and-click control for opening and closing switches.

707B

708B

Semiconductor Switch Matrix Mainframes

Six-slot and Single-slot Versions

- For those replacing Keithley's earlier 707A/708A mainframes and who prefer to minimize the levels of changes to their test systems, the Models 707B and 708B offer a GPIB interface and 707A/708A DDC command emulation capabilities to simplify the migration process. These users can incorporate the "B" models into their test systems without making any changes to their legacy code or hardware interface. However, these users will not be able to take full advantage of many of the throughput gains that TSP control provides, such as the new GPIB interface that allows you to control additional GPIB-compatible instruments and systems.
- A rear panel Universal Serial Bus (USB) port allows a host computer to communicate with and control the 707B/708B over a USB interface.

Optimized for Easy Integration with Series 2600A-Based Systems

The Models 707B and 708B are ideal companion products for systems that incorporate Series 2600A instrumentation, such as Keithley's ACS and S530 integrated test systems. These mainframes share the same TSP, Lua scripting language, and TSP-Link interface as the Series 2600A and support an ultra low current switch matrix (the Model 7174A) that complements the Model 2636A's low current sensitivity. The Models 707B/708B offer test system builders a switch matrix that is fast, scriptable, and works seamlessly with all Series 2600A models.

In common with Series 2600A instruments, the Models 707B/708B provide system builders with the advantages of the Keithley Test Script Builder (TSB) Integrated Development Environment (IDE). TSB IDE is a programming tool provided on the CD that accompanies each mainframe. It can be used to create, modify, debug, and store TSP scripts. It provides a project/file manager window to store and organize test scripts, a text-sensitive program editor (like Visual Basic) to create and modify test TSP code, and an immediate instrument control window to send GPIB commands and receive data from the instrument. The immediate window allows viewing the output of a given test script and simplifies debugging.



Model 708B rear panel



Model 707B rear panel

707B 708B

Semiconductor Switch Matrix Mainframes Six-slot and Single-slot Versions

Supported Cards

7072	8×12 Semiconductor Matrix 200V, 1A
7072-HV	8×12 HV Semiconductor Matrix 1300V, 0.1A
7173-50	4×12, 2-pole, High-Frequency Matrix Card
7174A	8×12 Low-Current, High-Speed Matrix Card, with 3-lug Triax Row and Column connects

Execution Speed

SYSTEM PERFORMANCE¹

COMMAND: channel.close ('ch_list') or channel.open ('ch_list')

Card	Single Command Execution Time (ms)			
	Ethernet	GPIB	TSP-Link	USB
7072	15.9	15.9	20.5	15.9
7072-HV	15.9	15.9	20.5	15.9
7173-50	7.9	7.9	11.5	7.9
7174A	1.9	1.9	5.5	1.9

1. Time between the start of a single digio.writebit (1, 1), channel.close ('ch_list') or channel.open ('ch_list') (which includes relay settle time), and digio.writebit (1, 0) command.

TRIGGER RESPONSE TIME

MAXIMUM TRIGGER RATE (setups per second):

7072:	≥65.
7072-HV:	≥65.
7173-50:	≥160.
7174A:	≥815.

TRIGGER IN TO START OF MATRIX READY PULSE (DDC Mode): ≤85μs.

TRIGGER IN TO TRIGGER OUT: ≤0.5μs.

TRIGGER TIMER ACCURACY: ≤0.5μs.

NOTES

1. Includes scan.scancount = 100, scan.stepcount ≥3, channel.connectrule = channel.OFF or 0, and relay settle time.

GENERAL

EMULATION: 707A/708A Device Dependent Commands (DDC). Since the architecture of the Model 707B/708B differs from the Model 707A/708A, some commands are different. Refer to notes in the 707B-901 Reference manual for additional details.

BREAK BEFORE MAKE: channel.connectrule= channel.BREAK_BEFORE_MAKE or 1.

MAKE BEFORE BREAK: channel.connectrule= channel.MAKE_BEFORE_BREAK or 2.

NONE: channel.connectrule= channel.OFF or 0, the system will close relays as it is able to without adhering to a rule.

IEEE-488: IEEE-488.1 compliant. Supports IEEE-488.2 common commands and status model topology.

USB 2.0 DEVICE (rear panel type B): Full and high speed, USBTMC compliant.

DIGITAL I/O INTERFACE

Connector: 25-pin female D.

Input/Output Pins: 14 open drain I/O bits.

Absolute Maximum Input Voltage: 5.25V.

Absolute Minimum Input Voltage: -0.25V.

Maximum Logic Low Input Voltage: 0.7V, +850μA max.

Maximum Logic High Input Voltage: 2.1V, +570μA.

Maximum Source Current (flowing out of Digital I/O bit): 960μA.

Maximum Sink Current @ Maximum Logic Low Voltage (0.7V): -5.0mA.

Absolute Maximum Sink Current (flowing into Digital I/O pin): -11mA.

5V Power Supply Pin: Limited to 600mA, solid state fuse protected.

ETHERNET: RJ-45 connector, 10/100BaseT, Auto-MDIX.

LXI COMPLIANCE: LXI Class C, Version 1.2.

POWER SUPPLY:

707B: 100V to 240VAC, 50Hz–60Hz, 210VA max.

708B: 100V to 240VAC, 50Hz–60Hz, 110VA max.

RELAY DRIVE:

707B: 30W (6V at 5.0A) max. per slot, 162W (6V at 27A) max. for all slots.

708B: 30W (6V at 5.0A) max.

SAFETY: Conforms to European Union Low Voltage Directive.

DIMENSIONS:

707B: 356mm high × 432mm wide × 574mm deep (14.0 in × 17.0 in × 22.6 in).

708B: 90mm high × 432mm wide × 574mm deep (3.5 in × 17.0 in × 22.6 in).

DIMENSIONS WITH CARD INSTALLED:

707B: 356mm high × 432mm wide × 612mm deep (14.0 in × 17.0 in × 24.1 in).

708B: 90mm high × 432mm wide × 612mm deep (3.5 in × 17.0 in × 24.1 in).

WEIGHT: 707B: 14.5kg (32 lbs). 708B: 7.3kg (16 lbs).

SHIPPING WEIGHT: 707B: 27.2kg (60 lbs). 708B: 16.4 kg (36 lbs).

ENVIRONMENT: For indoor use only.

Altitude: Maximum 2000 meters above sea level.

Operating: 0°– 50°C, 80% R.H. up to 35°C. Derate to 3% R.H./°C, 35°– 50°C.

Storage: - 25°C to 65°C.

Selector Guide

Switch Cards and Accessories for 707B, 708B, 707A, 708A

New Models 707B and 708B replace Models 707A and 708A

Keithley Instruments recently introduced two new semiconductor switch matrix mainframes: the Model 707B six-slot mainframe and the Model 708B one-slot mainframe. The two new mainframes replace the Models 707A and

708A that were introduced more than 20 years ago. The new models provide important new capabilities and are compatible with the four most popular switch cards; however, there are a few capabilities that are exclusive to the

older models. The table shows the important differences between the new and old models. The 707A and 708A models will be available for a limited time.

	New 707/8B	Legacy 707/8A
GPIO/DDC	✓	✓
GPIO/ICL	✓	
Ethernet (LXI)	✓	
TSP/TSP-Link	✓	
Webpage (LXI)	✓	
Light Pen		✓
Compatible with 7174A, 7072, 7072-HV, 7173-50 switch cards	✓	✓
Compatible with 7071, 7071-4, 7075 switch cards		✓



← NEW Model 707B Replaces Model 707A →

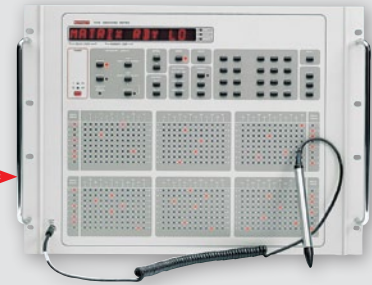

← NEW Model 708B Replaces Model 708A →



	LOW CURRENT			GENERAL PURPOSE			HIGH FREQUENCY
	7072	7072-HV	7174A	7071	7071-4	7075	7173-50
Page	203	204	207	201	202	205	206
Number of Channels	8×12	8×12	8×12	8×12	Dual 4×12	Eight 1×12	4×12
Card Configuration	Matrix	Matrix	Matrix	Matrix	Matrix	Multiplexer	Matrix
Contact Configuration	2 form A	2 form A	2 form A	3 form A	3 form A	2 form A	2 form C
Max. Voltage	200 V	1300 V	200 V	200 V	200 V	110 V	30 V
Max. Current	1 A	1 A	2 A	500 mA	500 mA	1 A	0.5 A
Max. Power	10 VA	10 VA		10 VA	10 VA	30 VA	10 VA
Contact Potential	<20 μV	<20 μV		<5 μV	<5 μV	<5 μV	<15 μV
Max. Offset Current	<1 pA	<1 pA	<100 fA	<100 pA	<100 pA	<100 pA	<200 pA
Recommended Frequency	15 MHz	4 MHz	30 MHz	3 MHz	3 MHz	30 MHz	200 MHz
Connection Type	3-lug triax	3-lug triax	3-lug triax	Connector	Connector	Connector	BNC
CE	Yes		Yes	Yes	Yes	Yes	Yes
Comments	Optimized for semiconductor applications.			Also provides screw terminal connection.	Screw terminals available on row connections.		
707B-708B Compatible	Yes	Yes	Yes	No	No	No	Yes
707A-708A Compatible	Yes	Yes	Yes	Yes	Yes	Yes	Yes

707B, 708B, 707A, 708A Switch Card Accessories

	Cables		Connectors		Adapters		Tools	
7071, 7071-4	7078-MTC-5	7078-MTC-20	7078-KIT	7078-MTR			7078-CIT	7078-HCT
7072	7078-TRX-3	7078-TRX-10			237-TRX-T	7078-TRX-BNC		
7174A	7078-TRX-3	7078-TRX-10			237-TRX-T	7078-TRX-BNC		
7072-HV	7078-TRX-3	7078-TRX-10			7078-TRX-BNC	237-TRX-T		
7075	7075-MTC	7076-CMTC	7076-RMTC		7078-TRX-GND	237-TRX-TBC		
7173-50	7173-50-CSEP							

1.888.KEITHLEY (U.S. only)

www.keithley.com

KEITHLEY

A GREATER MEASURE OF CONFIDENCE

7071

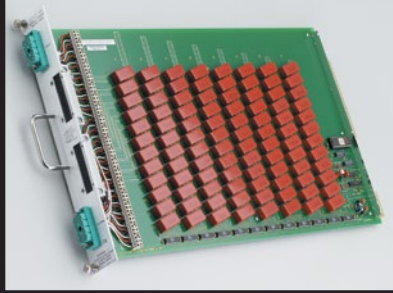

- 96 three-pole, Form A relay crosspoints
- High, Low, and Guard switched
- $5\mu\text{V}$ contact potential per crosspoint
- Signals to 200V and 1A
- Compatible with Models 707A and 708A

Ordering Information

7071 **8×12 General Purpose Matrix Card**

General Purpose Matrix Card

8×12

The Model 7071 General Purpose Matrix Card is an 8×12 configuration that switches High, Low, and Guard at each of the 96 relay crosspoints. The eight rows are connected automatically to the general purpose analog backplane when the matrix card is installed into the 707A and 708A mainframe. This allows for easy expansion in 12 column increments and eliminates the requirement for wiring between cards.

The matrix card will handle voltages up to 200V and currents up to 0.5A switched or 1A unswitched. A $5\mu\text{V}$ contact potential assures that the switch does not adversely affect low voltage sensitivity. The 3dB signal bandwidth is 5MHz. Guard inputs improve isolation between signals and assure 100pA offset currents into any electrical path.

ACCESSORIES AVAILABLE

7078-CIT	Contact Insertion and Extraction Tools
7078-HCT	Hand Crimping Tool
7078-KIT	Connector Kit
7078-MTC-5	Mass Terminated Cable Assembly, 1.5m (5 ft)
7078-MTC-20	Mass Terminated Cable Assembly, 6m (20 ft)
7078-MTR	Bulkhead Mount Receptacle with Contacts

SERVICES AVAILABLE

7071-3Y-EW	1-year factory warranty extended to 3 years from date of shipment
------------	---

- MATRIX CONFIGURATION:** 8 rows by 12 columns.
- CROSSPOINT CONFIGURATION:** 3-pole Form A (HI, LO, GUARD).
- CONNECTOR TYPE:** Quick disconnect using 38-pin connectors or screw terminals.
- MAXIMUM SIGNAL LEVEL:** 200V, 1A carry/0.5A switched, 10VA peak (resistive load).
- COMMON MODE VOLTAGE:** 200V maximum between any 2 pins or chassis.
- CONTACT LIFE:** Cold Switching: 10^8 closures. At Maximum Signal Level: 10^6 closures.
- PATH RESISTANCE (per conductor):** 0.6Ω initial, 1.5Ω at end of contact life.
- CONTACT POTENTIAL:** $5\mu\text{V}$ per crosspoint (HI to LO 1 minute after actuation).
- OFFSET CURRENT:** 100pA.
- ISOLATION:** Path: > $10^{10}\Omega$, 10pF. Differential: $10^9\Omega$, 45pF nominal. Common Mode: $10^9\Omega$, 165pF nominal.
- CROSSTALK:** -50dB at 1MHz, $50\Omega</math> load.$
- INSERTION LOSS (1MHz, $50\Omega</math> source, $50\Omega</math> load):$$** 0.1dB typical.
- 3dB BANDWIDTH ($50\Omega</math> load):$** 5MHz typical.
- RELAY SETTLING TIME:** 3ms.
- EMC:** Conforms to European Union Directive 89/336/EEC.
- SAFETY:** Conforms to European Union Directive 73/23/EEC (meets EN61010-1/IEC 1010).
- ENVIRONMENT: Operating:** 0° to 50°C , up to 35°C at 70% R.H. **Storage:** -25 to $+65^\circ\text{C}$.

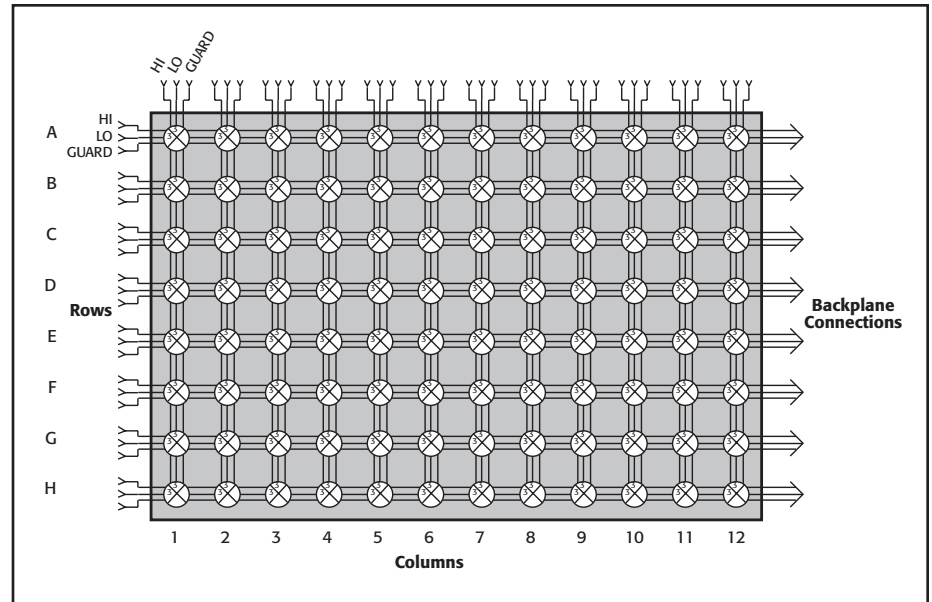

Use with Models 707A and 708A switching matrix mainframes

SWITCHING AND CONTROL

1.888.KEITHLEY (U.S. only)
www.keithley.com

KEITHLEY

A GREATER MEASURE OF CONFIDENCE

7071-4

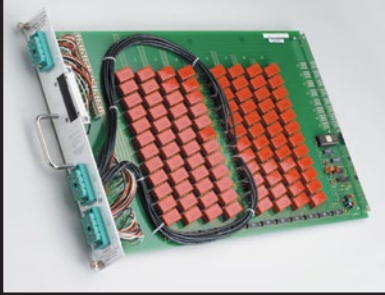

- Two independent 4×12 matrix switches
- 3-pole switching (HI, LO, GUARD)
- Connect to general purpose analog backplane
- Configuration easily adapted with jumpers
- 4×24 or dual 4×12 configuration
- Compatible with Models 707A and 708A

Ordering Information

7071-4 Dual 4×12 General Purpose Matrix Card

Accessories Supplied
Screw terminal adapter for 4×24 configuration

General Purpose Matrix Card

Dual 4×12

The Model 7071-4 Dual 4×12 General Purpose Matrix Card provides the capability to expand the number of columns that the Model 707A will support to a maximum of 720 in five 707A mainframes. This matrix card has two banks of four signal paths that connect through jumpers to the general purpose analog backplane in the 707A mainframe for automatic interconnect between cards. Jumpers may be removed to isolate any 4×12 matrix segment or repositioned to cascade segments into a 4×24 configuration.

Column connections to the matrix are through two 38-pin mass terminated connectors. The corresponding cable accessory, Model 7078-MTC, is constructed with 12 sets of shielded twisted pair circuits for excellent noise immunity and electrical separation. Custom cables and harnesses can be assembled using the 7078-KIT Connector Kit. The mating bulkhead connector, Model 7078-MTR, is also available.

ACCESSORIES AVAILABLE

7078-CIT	Contact Insertion and Extraction Tools
7078-HCT	Hand Crimping Tool
7078-KIT	Mass Terminated Plug with Contacts
7078-MTC-5	Mass Terminated Cable Assembly, 1.5m (5 ft)
7078-MTC-20	Mass Terminated Cable Assembly, 6m (20 ft)
7078-MTR	Mass Terminated Receptacle with Contacts

SERVICES AVAILABLE

7071-4-3Y-EW	1-year factory warranty extended to 3 years from date of shipment
--------------	---

MATRIX CONFIGURATION: Dual 4 rows by 12 columns.

Also configurable as 8 rows by 12 columns or 4 rows by 24 columns.

CROSSPOINT CONFIGURATION: 3 pole Form A (HI, LO, GUARD).

CONNECTOR TYPE: Quick disconnect using 38-pin connectors. In addition, screw terminals are available on rows.

MAXIMUM SIGNAL LEVEL: 200V, 1A carry/0.5A switched, 10VA peak (resistive load).

COMMON MODE VOLTAGE: 200V maximum between any 2 pins or chassis.

CONTACT LIFE:

Cold Switching: 10⁸ closures.

At Maximum Signal Level: 10⁵ closures.

PATH RESISTANCE (per conductor): <0.6Ω initial, <1.5Ω at end of contact life.

CONTACT POTENTIAL: <5μV per crosspoint (HI to LO, <1 minute after actuation).

OFFSET CURRENT: <100pA (HI to LO).

ISOLATION:

Path: > 10¹⁰Ω, <10pF.

Differential: 10⁹Ω, 45pF nominal.

Common Mode: 10⁹Ω, 300pF nominal.

CROSSTALK: <-45dB at 1MHz, 50Ω load.

INSERTION LOSS (1MHz, 50Ω source, 50Ω load): 0.1dB typical.

3dB BANDWIDTH (50Ω load): 5MHz typical.

RELAY SETTLING TIME: <3msec.

EMC: Conforms to European Union Directive 89/336/EEC.

SAFETY: Conforms to European Union Directive 73/23/EEC (meets EN61010-1/IEC 1010).

ENVIRONMENT:

Operating: 0° to 50°C, up to 35°C at 70% R.H.

Storage: -25° to 65°C.

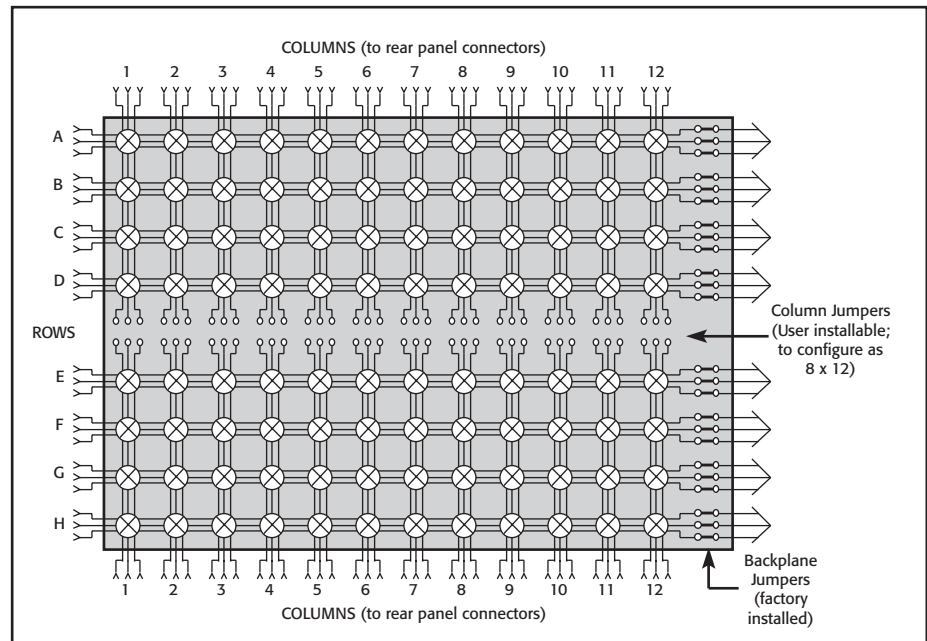

1.888.KEITHLEY (U.S. only)

www.keithley.com

KEITHLEY

A GREATER MEASURE OF CONFIDENCE

7072

Semiconductor Matrix Card

8x12

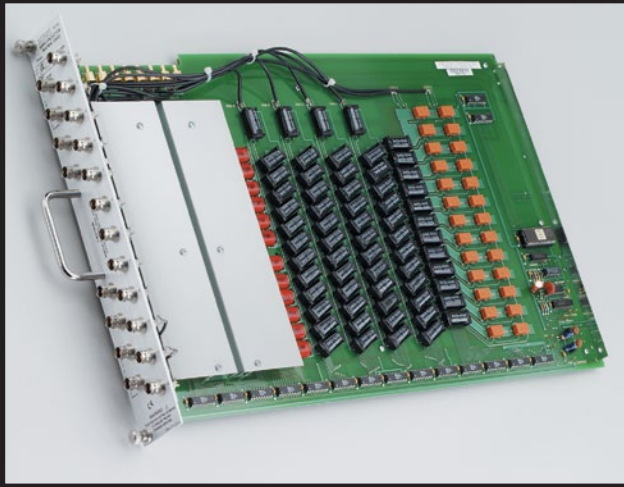

- Two sub-picoamp current paths
- Two DC to 1MHz C-V paths
- Four high isolation signal paths
- 3-lug triaxial connection
- Compatible with Models 707A, 707B, 708A, and 708B

Ordering Information

7072 8x12 Semiconductor Matrix Card

Accessories Supplied

Instruction manual and four SMB expansion cables (CA-54-1)

The Model 7072 Semiconductor Matrix Card is designed specifically to handle low-level and high-impedance measurements encountered in semiconductor parametric tests on wafers and devices. This unique design provides two low-current circuits with specified 1pA maximum offset current for sensitive sub-picoamp measurement resolution and two C-V paths for measurement of Capacitance Voltage characteristics from DC to 1MHz. Four additional high-quality signal paths with <20pA offset current provide for general-purpose signal switching up to 100nA or 200V.

Connections are 3-lug triax with the outer shell connected to chassis for safety and noise shielding. The center conductor is fully surrounded by the inner conducting shield, so that fully guarded measurements can be made to achieve higher isolation and to improve measurement speed and accuracy.

Isolation relays on the low-current and C-V paths automatically disconnect unused circuits to achieve minimum interference and peak performance. The 707A or 708A mainframe allows each row (signal path) to be programmed for Break-Before-Make or Make-Before-Break operation.

For applications requiring connections

to a large number of devices or test points, the 7072 matrix can be expanded with additional cards. The low-current and C-V rows can be extended to other cards with coaxial jumpers. The other four high-quality signal paths connect directly to the 707A backplane for expansion.

ACCESSORIES AVAILABLE

237-TRX-T	3-Lug Triax Tee Adapter
7078-TRX-BNC	3-Lug Triax to BNC Adapter
7078-TRX-3	3-Lug Triax Cable, 0.9m (3 ft)
7078-TRX-10	3-Lug Triax Cable, 3m (10 ft)
7078-TRX-TBC	3-Lug Female Triax Bulkhead Connector with Cap

SERVICES AVAILABLE

7072-3Y-EW	1-year factory warranty extended to 3 years from date of shipment
------------	---

	Low-Current (Rows A - B)	General-Purpose (Rows C - F)	C-V (Rows G - H)
CROSSPOINT CONFIGURATION:	2-pole Form A	2-pole Form A	1-pole Form A, Common Guard
OFFSET CURRENT:	<1 pA	<20 pA	<20 pA
PATH ISOLATION: Resistance:	>10 ¹³ Ω	>10 ¹² Ω	>10 ¹² Ω
Capacitance (nominal):	0.4 pF	1 pF	0.6 pF
CROSSTALK			
1 MHz, 50Ω load (typical):	<-50 dB	<-40 dB	<-50 dB
3dB BANDWIDTH (typical), 50Ω Load:	15 MHz	8 MHz	5 MHz

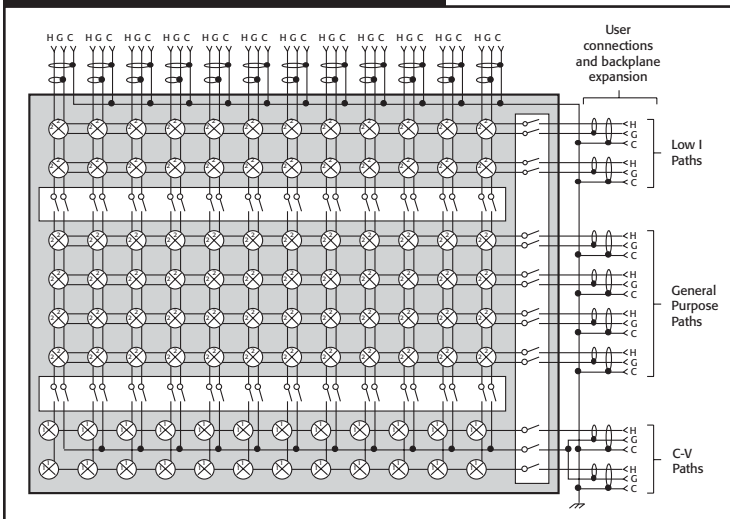

MATRIX CONFIGURATION: 8 rows by 12 columns.

CONNECTOR TYPE: 3-lug triaxial (Signal, Guard, Chassis).

MAXIMUM SIGNAL LEVEL: 200V, 1A carry/0.5A switched, 10VA peak (resistive load).

COMMON MODE VOLTAGE: 200V maximum between any 2 pins or chassis.

CONTACT LIFE:

Cold Switching: 10⁷ closures.

At Maximum Signal Level: 10⁵ closures.

PATH RESISTANCE (per conductor): <1Ω initial, <3.5Ω at end of contact life.

CONTACT POTENTIAL: <40μV per crosspoint (Signal to Guard).

RELAY SETTLING TIME: <15ms.

INSERTION LOSS (1MHz, 50Ω source, 50Ω load): 0.1dB typical.

EMC: Conforms to European Union Directive 89/336/EEC.

SAFETY: Conforms to European Union Directive 73/23/EEC (meets EN61010-1/IEC 1010).

ENVIRONMENT:

OFFSET CURRENT and PATH ISOLATION Specifications: 23°C, <60% R.H.

Operating: 0° to 50°C, up to 35°C at 70% R.H.

Storage: -25° to +65°C.

Use with Models 707B, 708B, 707A, and 708A switching matrix mainframes

SWITCHING AND CONTROL

1.888.KEITHLEY (U.S. only)
www.keithley.com

KEITHLEY

A GREATER MEASURE OF CONFIDENCE

7072-HV

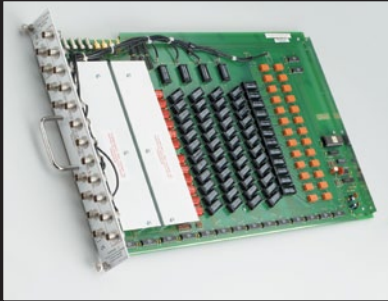

- Two 1300V, sub-picoamp current paths
- Six 200V, 20pA paths
- For use with Model 2410 and Model 237 SMU
- 3-lug triaxial connections
- Compatible with Models 707A, 707B, 708A, and 708B

Ordering Information

7072-HV 8×12 High Voltage Semiconductor Matrix Card

High Voltage Semiconductor Matrix Card

8×12

The Model 7072-HV is designed to switch low-level, high-voltage, and high-impedance signals for semiconductor parametric tests on wafers and devices. This unique design provides two signal paths capable of switching 1300V with less than 1pA of offset current. The two C-V paths may be used for measurement of capacitance voltage characteristics from DC to 1MHz or for switching low currents with a common ground. Four additional high quality signal paths with less than 20pA offset current provide for signal switching to 200V.

Connections are 3-lug triax with the outer shell connected to chassis for safety and noise shielding. The center conductor is fully surrounded by the inner conducting shield to provide fully guarded measurements with higher isolation and improved measurement speed and accuracy.

7072-HV Applications

The Model 7072-HV, in conjunction with the Model 237 SMU, 2410 SourceMeter® instrument, Model 6487 Picoammeter/Voltage Source, or Model 6517B Electrometer/High Resistance Meter, can address a wide variety of semiconductor device and material characterization needs.

The high voltage signals encountered in breakdown measurements or oxide integrity testing can be easily switched with this matrix card. Signals connected to the High V, Low I paths are automatically isolated from the rest of the card.

For applications requiring connections to a large number of devices or test points, the 7072-HV matrix can be expanded with additional cards. The high voltage and C-V rows can be extended to other cards with coaxial jumpers. The other four high-quality signal paths connect directly to the 707A or 708A backplane for expansion.

ACCESSORIES AVAILABLE

237-TRX-T	3-Lug Triax Tee Adapter
237-TRX-TBC	3-Lug High Voltage Female Triax Bulkhead Connector
7078-TRX-3	3-Lug Triax Cable, 0.9m (3 ft)
7078-TRX-10	3-Lug Triax Cable, 3m (10 ft)
7078-TRX-BNC	3-Lug Triax to BNC Adapter

FOR USE AT 200V OR LESS

7078-TBC	3-Lug Female Triax Bulkhead Connector with Cap
----------	--

SERVICES AVAILABLE

7072-HV-3Y-EW	1-year factory warranty extended to 3 years from date of shipment
---------------	---

MATRIX CONFIGURATION: 8 rows by 12 columns.

CONNECTOR TYPE: Three-lug triaxial (Signal, Guard, Chassis).

CONTACT LIFE: Cold Switching: 10⁷ closures.

At Maximum Signal Level: 10⁵ closures.

PATH RESISTANCE (per conductor): <1Ω initial, <3.5Ω at end of contact life.

RELAY SETTling TIME: <15ms.

INSERTION LOSS (1MHz, 50Ω source, 50Ω load): 0.1dB typical.

EMC: Conforms to European Union Directive 89/336/EEC.

SAFETY: Conforms to European Union Directive 73/23/EEC (meets EN61010-1/IEC 1010).

ENVIRONMENT:

OFFSET CURRENT and PATH ISOLATION Specifications: 23°C, <60% R.H.

Operating: 0° to 50°C, up to 35°C at 70% R.H. **Storage:** -25° to +65°C.

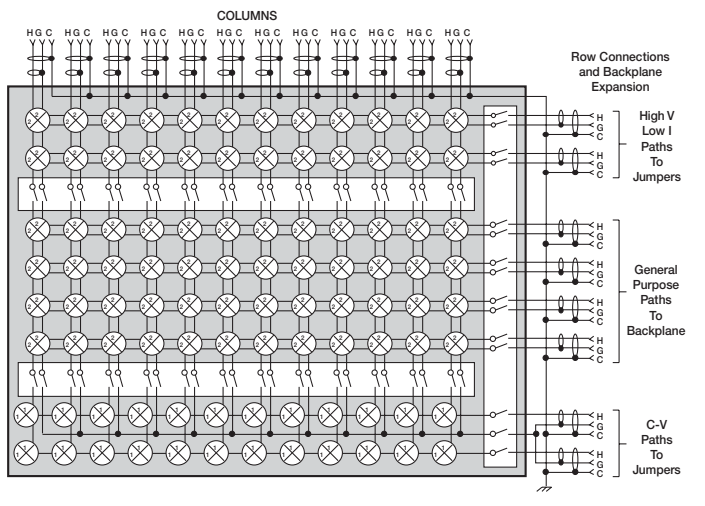

	Low Current (Rows A–B)	General Purpose (Rows C–F)	C-V (Rows G–H)
CROSSPOINT CONFIGURATION	2-pole Form A	2-pole Form A	1-pole Form A, Common Guard
OFFSET CURRENT	<1 pA	<20 pA	<20 pA
PATH ISOLATION:			
Resistance	>10 ¹³ Ω	>10 ¹² Ω	>10 ¹² Ω
Capacitance (nominal)	0.4 pF	1 pF	0.6 pF
CROSSTALK:			
1 MHz, 50Ω load (typical)	<-60 dB	<-40 dB	<-50 dB
3dB BANDWIDTH (typical), 50Ω Load	4 MHz	8 MHz	5 MHz
MAXIMUM SIGNAL LEVEL			
Maximum between any 2 pins or chassis:	1300 V	200 V	200 V
Maximum between signal & guard: 1A carry/0.5A switched, 10VA peak (resistive load)	200 V	200 V	200 V
CONTACT POTENTIAL (Signal to Guard):	<50 μV	<20 μV	<40 μV

1.888.KEITHLEY (U.S. only)

www.keithley.com

KEITHLEY

A GREATER MEASURE OF CONFIDENCE

7075

Two-pole Multiplexer Card Eight 1x12

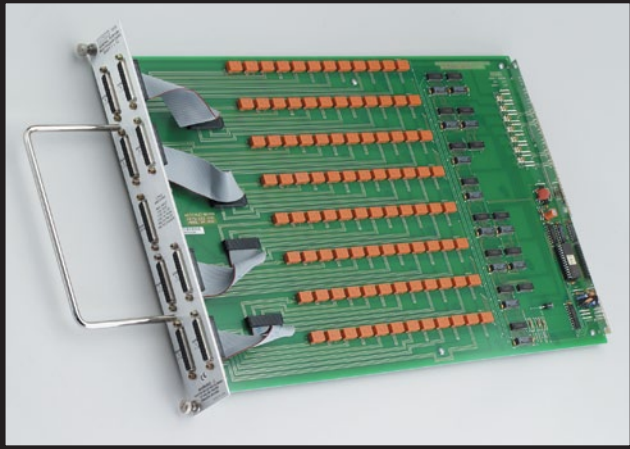

The Model 7075 is a general purpose multiplex switching card that consists of eight banks of independent 112 multiplexer switching. Each bank has two switched circuits (HI and GUARD). The row is connected through jumpers on the card to the general purpose analog backplane in the Model 707A or 708A switching mainframe. This provides the interconnect between cards for multiplexer expansion (124, 136, etc.). Jumpers may be removed to isolate any bank. A single card can be expanded to 196 by reconfiguring the supplied bank-to-bank jumpers. Eight 25-pin D connectors are provided for bank connections and one for row connection.

- Low cost
- <5μV voltage offset
- <100pA offset current
- 110V, 1A signal levels
- Uses standard 25-pin D connectors
- Compatible with Models 707A and 708A

Ordering Information

7075 Eight 1x12 Two-pole Multiplexer Card

Accessories Supplied

Jumpers for multiplexer expansion

MULTIPLEX CONFIGURATION: Eight 1x12 banks. Adjacent banks can be connected together. Jumpers can be removed to isolate any bank from the backplane.

CONTACT CONFIGURATION: 2-pole Form A (HI, GUARD).

CONNECTOR TYPE: 25-pin subminiature D connector, eight for bank connection, one for row connection.

MAXIMUM SIGNAL LEVEL:

DC Signals: 110V DC pin-to-pin, 1A switched, 30VA (resistive load).

AC Signals: 175V AC peak pin-to-pin, 1A switched, 60VA (resistive load).

COMMON MODE VOLTAGE: 110V DC, 175V AC peak pin-to-pin or pin-to-chassis.

CONTACT LIFE:

Cold Switching: 10⁸ closures.

At Maximum Signal Level: 10⁵ closures.

CHANNEL RESISTANCE (per conductor): <0.50Ω initial, <1.5Ω at end of contact life.

CONTACT POTENTIAL: <5μV per contact pair (HI to GUARD).
OFFSET CURRENT: <100pA.

CROSSTALK (1MHz, 50Ω load): Bank: <-60dB.
Channel: <-60dB.

INSERTION LOSS (1MHz, 50Ω source, 50Ω load): 0.1dB typical.

ISOLATION:

Bank: >10¹⁰Ω, <3pF.

Channel: >10¹⁰Ω, <5pF.

Differential: Configured as 1x12: >10⁹Ω, <100pF nominal. Configured as 1x96: >10⁹Ω, <600pF nominal.

Common Mode: Configured as 1x12: >10⁹Ω, <165pF nominal. Configured as 1x96: >10⁹Ω, <700pF nominal.

3dB BANDWIDTH (50Ω load):

Configured as 1x12: 30MHz typical.

Configured as 1x96: 2.5MHz typical.

RELAY SETTLING TIME: <3ms.

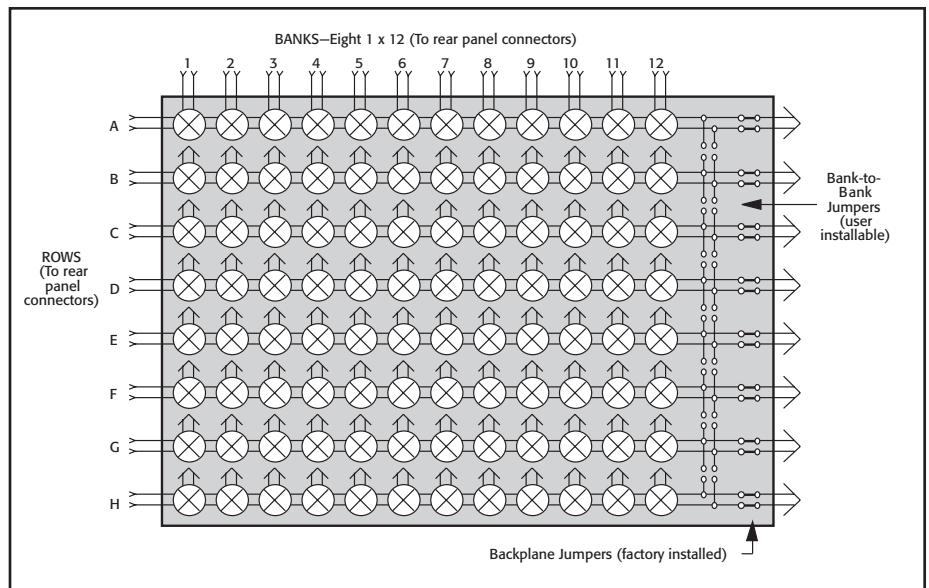

Use with Models 707A and 708A switching matrix mainframes

SWITCHING AND CONTROL

1.888.KEITHLEY (U.S. only)

www.keithley.com

KEITHLEY

A GREATER MEASURE OF CONFIDENCE

7173-50



- 200MHz bandwidth
- <2ns rise time
- 50Ω impedance
- <15μV offset
- <200pA offset current
- 2-pole switching
- Compatible with Models 707A, 707B, 708A, and 708B

Ordering Information

7173-50 4×12, High Frequency Two-pole Matrix Card

SERVICES AVAILABLE

7173-50-3Y-EW 1-year factory warranty extended to 3 years from date of shipment

High Frequency Matrix Card

4×12, Two-pole

The Model 7173-50 combines high frequency performance with excellent DC switching characteristics. It provides 200MHz bandwidth in a 4×12 configuration. Offset voltage is <15μV per crosspoint, and offset current is <200pA. The combined AC and DC capabilities make it ideal for mixed signal applications where both high frequency and low level DC signals must be switched—for example, testing ADCs or DACs, which involves measuring both digital and analog signals.

The Model 7153-50 has a rise time of <2ns. It also features 2-pole switching at each crosspoint—HI and Shield—useful in 4-wire capacitance measurements where it is important to tie the shields of each connection together at the capacitance meter. BNC card connections are compatible with a wide variety of test equipment.

The Model 7173-50-CSEP expansion cables are four 25-inch cables and can expand a switching configuration to include more than one Model 7173-50. One cable is required to expand each row or column connection between adjacent cards. For example, connect the rows of two 7173-50 cards to create a 4×24 matrix or connect the columns to create an 8×12 matrix.

MATRIX CONFIGURATION: 4 rows by 12 columns.

CROSSPOINT CONFIGURATION: 2-pole Form C with Row Isolator (HI, LO).

CHARACTERISTIC IMPEDANCE: 50Ω nominal.

CONNECTOR TYPE: BNC.

MAXIMUM SIGNAL LEVEL: 30V, 0.5A switched, 10VA.

COMMON MODE VOLTAGE: 42V peak (LO to Chassis).

CONTACT LIFE: Cold Switching: 5×10⁶ closures.

At Maximum Signal Level: 3×10⁵ closures.

PATH RESISTANCE:

HI: <2.0Ω initial, <4.0Ω at end of contact life.

LO: <0.10Ω initial, <0.15Ω at end of contact life.

CONTACT POTENTIAL: <15μV per crosspoint (HI to LO).

RELAY SETTling TIME: <6ms.

OFFSET CURRENT: <200pA (HI to LO).

AC PERFORMANCE (50Ω load and 50Ω source):

	1MHz	10MHz	100MHz	200MHz
Crosstalk:¹	<-85dB	<-50dB	<-35dB	
Insertion Loss:	<0.2dB	<0.4dB	<1.5dB	<3.0dB
VSWR (typical):		1.4	1.7	

¹Closed crosspoint to closed crosspoint

ISOLATION: Path: >10⁶Ω, <0.040pF. **Differential:** >10⁶Ω, 150pF nominal. **Common Mode:** >10⁶Ω, 9400pF nominal.

RISE TIME (50Ω load and 50Ω source): <2ns.

EMC: Conforms to European Union Directive 89/336/EEC.

SAFETY: Conforms to European Union Directive 73/23/EEC (meets EN61010-1/IEC 1010).

ENVIRONMENT: Operating: 0° to 50°C, up to 35°C at 70% R.H. **Storage:** -25° to 65°C.

Specifications apply for one 7173-50 with all row isolators in automatic mode.

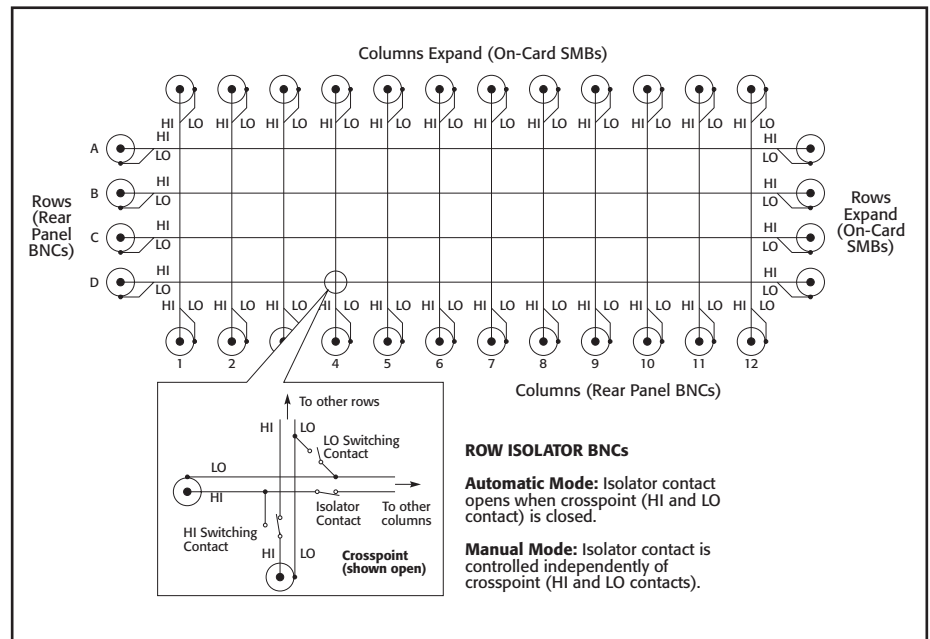
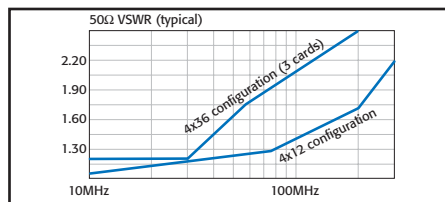
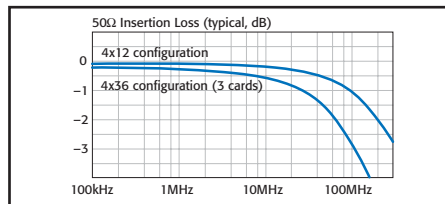
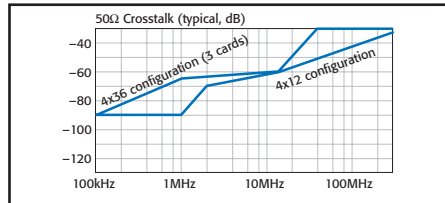

1.888.KEITHLEY (U.S. only)

www.keithley.com



A GREATER MEASURE OF CONFIDENCE

7174A

High Speed, Low Leakage Current Matrix 8x12



- **Fast time to measurement**
- **Low leakage (<100fA offset on all signal paths)**
- **2-pole switching, signal, and guard**
- **200V, 2A signal levels**
- **Designed for use with Keithley Model 4200-SCS, SMUs, 2635A and 2636A SourceMeter® Instruments, and Agilent B1500**
- **Compatible with Models 707A, 707B, 708A, and 708B**

Ordering Information

7174A 8x12 High Speed, Low Current Matrix

Accessories Supplied

Eight row interconnect cables for card to card matrix expansion

The Model 7174A Low Current Matrix Card is designed for semiconductor research, development, and production applications requiring high quality, high performance switching of I-V and C-V signals. The Model 7174A is ideal for use with Keithley Models 2635A and 2636A SourceMeter Instruments, Model 4200-SCS, and the Agilent B1500. The card's configuration is 8 rows x 12 columns, with signal and guard switched at each crosspoint. Offset current has been reduced dramatically to <100fA on all pathways. Significant reductions in the level of parasitic capacitances in the Model 7174A help speed the process of making low level measurements.

The Model 7174A provides an optimum solution to switching the lower level signals common to today's semiconductor characterization tests. The card's low leakage and minimal dielectric absorption ensure that key device measurements can be performed many times faster than with current switching technologies. Connections are 3-lug triax with the outer shell connected to chassis for safety and noise shielding. The center conductor is fully surrounded by the inner conducting shield allowing fully guarded measurements to be made with higher isolation and improved speed and accuracy.

For applications that require making connections to a large number of devices or test points, the Model 7174A matrix can be expanded with additional cards. On-card connectors are provided to connect the rows (column expansion) between other 7174A cards in adjacent slots of the Model 707B switching mainframe. Eight female-to-female cables are provided with each 7174A to simplify expansion. Up to six 7174A cards can be connected in a single 707A switching mainframe to form an 8x72 or 12x60 matrix.

MATRIX CONFIGURATION: Single 8 rowsx12 columns.

Expanding the columns can be done internally by connecting the rows of multiple 7174A cards together with coax jumpers.

CROSSPOINT CONFIGURATION: 2-pole Form A (Signal Guard).

CONNECTOR TYPE: 3-lug triax (Signal, Guard, Chassis).

MAXIMUM SIGNAL LEVEL:

Pin-to-pin or Pin-to-Chassis: 200V, 2A carry current.

CONTACT LIFE: Cold Switching: 10⁸ closures.

OFFSET CURRENT: 100fA max., 10fA typical (with 0V applied to inputs and outputs).

ISOLATION: Path (Signal to Signal): >2x10¹⁴Ω, 1pF.
Common (Signal to Chassis): >10¹⁴Ω, <10pF.

SETTLING TIME: <2.5s to 400fA (all pathways) after 10V applied (typical).

CROSSTALK (1MHz, 50Ω Load): <-70dB.

INSERTION LOSS (1MHz, 50Ω Load): <-0.2dB typical.

3dB BANDWIDTH:

(50Ω Load, 50Ω Source): 30MHz typical.

(1MΩ Load, 50Ω Source): 40MHz typical.

RELAY SETTLING TIME: <1ms.

EMC: Conforms to European Union Directive 89/336/EEC.

SAFETY: Conforms to European Union Directive 73/23/EEC (meets EN61010-1/IEC 1010).

ENVIRONMENT:

Offset Current and Path Isolation Specifications: 23°C, <60% R.H.

Operating: 0° to 50°C, up to 35°C at 70% R.H.

Storage: -25° to +65°C.

MAXIMUM LEAKAGE:

Pin to Ground: 0.01pA/V. Pin to Pin: 0.005pA/V.

INSULATION RESISTANCE: 6.7x10¹³Ω minimum.

CAPACITANCE: (Guard Driven): Path to Ground: <10pF.
Path to Path: 1pF typical.

ACCESSORIES AVAILABLE

237-TRX-T	3-Lug Triax Tee Adapter
7078-TRX-TBC	3-Lug Triax to BNC Adapter
7078-TRX-3	3-Lug Triax Cable, 0.9m (3 ft.)
7078-TRX-10	3-Lug Triax Cable, 3m (10 ft.)
7078-TBC	3-Lug Female Triax Bulkhead Connector with Cap

SERVICES AVAILABLE

7174A-3Y-EW	1-year factory warranty extended to 3 years from date of shipment
-------------	---

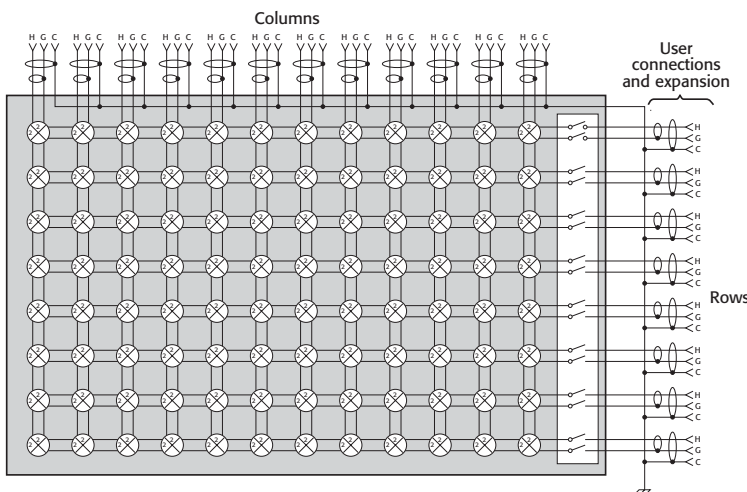

System 41

RF/Microwave Signal Routing Systems



Mainframe Optimized for Controlling RF/Microwave Switches

The System 41 is optimized solely for microwave signal routing applications. We've integrated the ability to control up to 240 RF/microwave channels within the chassis that houses the switches to provide an optimum combination of price and performance in just seven inches of rack space. The System 41 can be configured with one of the three standard switch modules.

Fully Integrated, Turnkey Solutions

Keithley can provide a standard turnkey signal routing system, complete with an optimized Keithley controller, system power supply, all power and control cables, rack mount assembly, and low-loss microwave cables in one integrated chassis.

Keithley can provide a standard turnkey signal routing system, complete with an optimized Keithley controller, system power supply, all power and control cables, rack mount assembly, and low-loss microwave cables in one integrated chassis.

Superior RF/Microwave Performance

The System 41 integrates relays from the leading suppliers in the industry, enabling us to offer the lowest insertion loss, VSWR, and crosstalk performance specifications available. All internal connections between the components are implemented using semi-flex or semi-rigid RF cables for high signal integrity.

Standard Microwave Switching Modules

Keithley provides three standard microwave switching modules: an 18GHz 1010 non-blocking matrix, an 18GHz 66 non-blocking matrix, and an 18GHz 172 multiplexer that can be configured as two independent 136 multiplexers.

Get Up and Running Quickly

To begin using the System 41, simply install it in a rack and connect the input and output lines. All RF input/output connections are easily accessible, making system setup and maintenance fast and uncomplicated.

The control unit's front panel display provides continuous, real-time information on the status of all controlled components. This makes it possible to operate the system manually, not just automatically, speeding and simplifying test verification and troubleshooting. Both start-up time and downtime are minimized, which helps maximize production time.

Phase Matching Option

The System 41 offers a phase match option for the 172 multiplexer. This solution provides equal length, phase matched paths of both the RF cabling and the switching topology. Only high performance switches are used to ensure contact resistance reliability over time.

Light Pen Programming

A light pen provides point-and-click programming from the front panel. By selecting the desired channels or range of channels, the scan list can be built, matrix patterns created, channels opened or closed, and patterns stored in memory.

APPLICATIONS

- Cellular and cordless phones
- Specialized mobile radios
- Base stations
- Specialized antenna systems
- RF components, including RFICs
- Wireless peripherals, including Bluetooth devices
- Broadband wireless transceivers
- High speed digital communications, including SONET speeds 3Gbps and 10Gbps

- Integrated solution, including both controller and microwave components in 4U (7") package
- Three standard microwave switch modules
 - 10x10 unterminated matrix
 - 6x6 unterminated matrix
 - 1x72/dual 1x36 unterminated multiplexer
- Unique front panel enables interactive control as well as real-time status display
- DC to 18GHz frequency range
- Pre-programmed, turnkey solutions
- Phase matching

Ordering Information

Contact a Keithley representative for pricing.

Accessories Supplied
Programming light pen

1.888.KEITHLEY (U.S. only)

www.keithley.com

KEITHLEY

A GREATER MEASURE OF CONFIDENCE

System 41

RF/Microwave Signal Routing Systems

S41/RF 6×6 System Specifications

FREQUENCY	DC–8 GHz	8–18 GHz
INSERTION LOSS	2.5 dB max.	4.0 dB max.
VSWR	1.5:1	2.0:1
ISOLATION	70 dB min.	60 dB min.

S41/RF 10×10 System Specifications

FREQUENCY	DC–8 GHz	8–18 GHz
INSERTION LOSS	3.5 dB max.	5.5 dB max.
VSWR	1.5:1	2.0:1
ISOLATION	70 dB min.	60 dB min.

S41/RF 1×72 System Specifications

FREQUENCY	DC–8 GHz	8–18 GHz
INSERTION LOSS	1.0 dB max.	2.5 dB max.
VSWR	1.5:1	2.0:1
ISOLATION	70 dB min.	60 dB min.

NOTE: This system is also configurable as two individual 1×36 multiplexers.

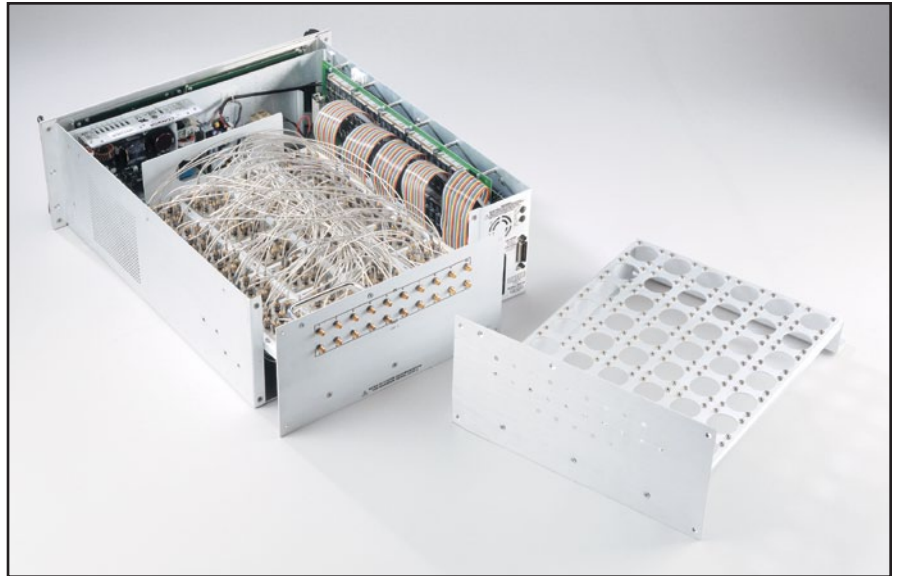

S41/RF 10×10 Non-Blocking Matrix

ACCESSORIES AVAILABLE

7007-1	Shielded GPIB Cable, 1m (3.3 ft)
7007-2	Shielded GPIB Cable, 2m (6.6 ft)
KPCI-488LPA	IEEE-488 Interface/Controller for the PCI Bus
KUSB-488B	IEEE-488 USB-to-GPIB Interface Adapter
S41-RMK-1	Fixed Rack Mounting Kit

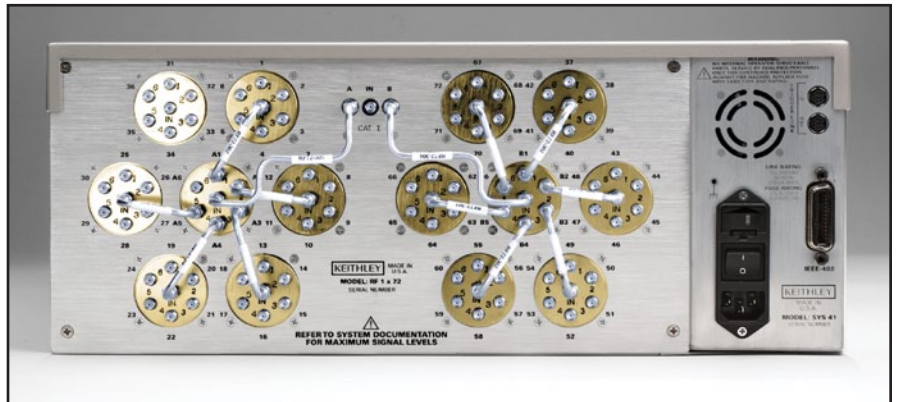

S41/RF 1×72 Multiplexer

1.888.KEITHLEY (U.S. only)

www.keithley.com

KEITHLEY

A GREATER MEASURE OF CONFIDENCE

System 46

RF/Microwave Switch System

32-channel, Unterminated



- Compact RF/microwave switching system only 2U high
- Built-in contact closure counter to monitor switch cycles
- Standard configuration allows up to 32 channels of switching
- Simple control with built-in GPIB/IEEE-488 interface bus
- Channel characterization data storage
- Frequency ranges up to 40GHz

APPLICATIONS

- Cellular and cordless phones
- Specialized mobile radios
- Base stations
- Specialized antenna systems
- RF components, including RFICs
- Wireless peripherals, including Bluetooth devices
- Broadband wireless transceivers
- High speed digital communications, including SONET speeds 3Gbps and 10Gbps

Flexible Solutions in a Compact Package

The S46 Microwave Switch System is designed to simplify the automated switching needed to test a wide range of telecommunications products and devices. The S46 can control 32 relay contacts in a package as small as a 2U high (3.5 in) full-rack enclosure. Standard configurations make it simple to select a system that meets the specifications of the testing application without the expense of unnecessary switches or other features. This "just what you need and no more" design philosophy allows S46 systems to provide outstanding price/performance value.

The enclosures used in standard S46 configurations can accommodate eight SPDT unterminated coaxial microwave relays and four multi-pole, unterminated, coaxial microwave relays. Any of these multi-pole unterminated relays can be one of the following relay types: SP4T or SP6T. S46 switching systems can be used as multiplexers, matrices, independent relays, or a combination of configurations. To order a standard system, simply select the number of relays and their location on the front panel. As test requirements change, relays can be easily added to the system to create a new switch configuration.

Frequency Range

To accommodate the rapidly evolving test requirements in RF/microwave applications, the S46 has ordering provisions for frequency ranges up to 40GHz. Configuration options include DC to 18GHz, DC to 26.5GHz, and DC to 40GHz.

Simple Operation

The S46 switch system's 32 control channels can be operated via the IEEE-488 interface bus with a minimal set of instructions. This small instruction set ensures the system can be set up and running quickly. Front panel LEDs indicate the status of all relay contacts continuously to allow the user to monitor system operation easily.

Excellent Microwave Switching Performance

Keithley's experience and partnerships with leading manufacturers in the microwave relay industry allow Keithley to offer the lowest insertion loss, VSWR, and crosstalk performance specifications available. Low-loss, semi-flexible RF cables are available as accessories to maximize signal integrity.

Maximum System Up-Time and Enhanced System Performance

The S46 controller automatically counts relay contact closures to allow equipment maintenance personnel to assess when the relays are nearing the end of their mechanical life. In this way, preventive maintenance can be performed in a timely way during scheduled shutdowns, avoiding unplanned shutdowns and the resulting loss of production time.

In addition to counting contact closures, the S46 has a portion of its memory available to store S-parameters or calibration constants for each relay contact or each pathway. If a specific performance parameter is critical, such as Voltage Standing Wave Ratio (VSWR) or insertion loss, the parameter can be stored in memory for use in trend analysis between scheduled maintenance shutdowns. Stored parameters can also be used for compensation to enhance accuracy during RF measurements.

1.888.KEITHLEY (U.S. only)

www.keithley.com

KEITHLEY

A GREATER MEASURE OF CONFIDENCE

System 46

RF/Microwave Switch System

32-channel, Unterminated

Standard Performance Data of an 18GHz, 1×12 Multiplexer

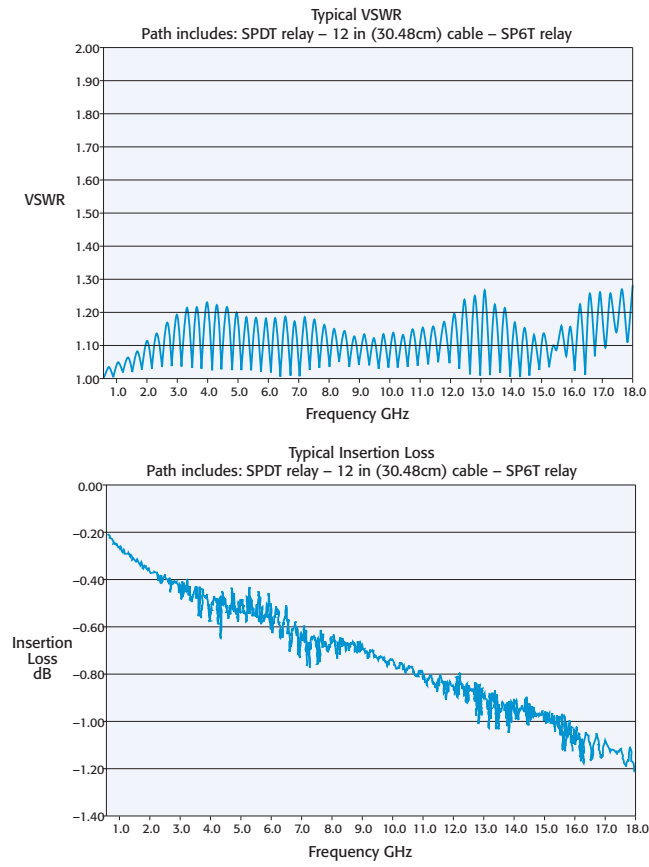

ACCESSORIES AVAILABLE

CABLING

S46-SMA-0.5	DC–18GHz, Low Loss, Semi-Flex SMA-SMA Cable Assembly, 0.152m (6 in.)
S46-SMA-1	DC–18GHz, Low Loss, Semi-Flex SMA-SMA Cable Assembly, 0.305m (12 in.)
S46-SMA-1.7	DC–18GHz, Low Loss, Semi-Flex SMA-SMA Cable Assembly, 0.518m (20.4 in.)
S46-SMA26-0.5	DC–26.5GHz, Low Loss, Semi-Flex SMA-SMA Cable Assembly, 0.152m (6 in.)
S46-SMA26-1	DC–26.5GHz, Low Loss, Semi-Flex SMA-SMA Cable Assembly, 0.305m (12 in.)
S46-SMA26-1.7	DC–26.5GHz, Low Loss, Semi-Flex SMA-SMA Cable Assembly, 0.518m (20.4 in.)
TL-24	SMA Cable Torque Wrench

SWITCH KITS

S46-SPDT-KIT	Standard Performance 18GHz Unterminated SPDT Relay and Control Cable Assembly
S46-SP4T-KIT	Standard Performance 18GHz Unterminated SP4T Relay and Control Cable Assembly
S46-SP6T-KIT	Standard Performance 18GHz Unterminated SP6T Relay and Control Cable Assembly
S46-SPDT-KIT-R	High Performance 18GHz Unterminated SPDT Relay and Control Cable Assembly
S46-SP4T-KIT-R	High Performance 18GHz Unterminated SP4T Relay and Control Cable Assembly
S46-SP6T-KIT-R	High Performance 18GHz Unterminated SP6T Relay and Control Cable Assembly
S46-SPDT-KIT-26	High Performance 26.5GHz Unterminated SPDT Relay and Control Cable Assembly
S46-SP4T-KIT-26	High Performance 26.5GHz Unterminated SP4T Relay and Control Cable Assembly
S46-SP6T-KIT-26	High Performance 26.5GHz Unterminated SP6T Relay and Control Cable Assembly
S46-SPDT-KIT-40	High Performance 40GHz Unterminated SPDT Relay and Control Cable Assembly
S46-SP4T-KIT-40	High Performance 40GHz Unterminated SP4T Relay and Control Cable Assembly
S46-SP6T-KIT-40	High Performance 40GHz Unterminated SP6T Relay and Control Cable Assembly

Examples of Standard System Switch Configurations

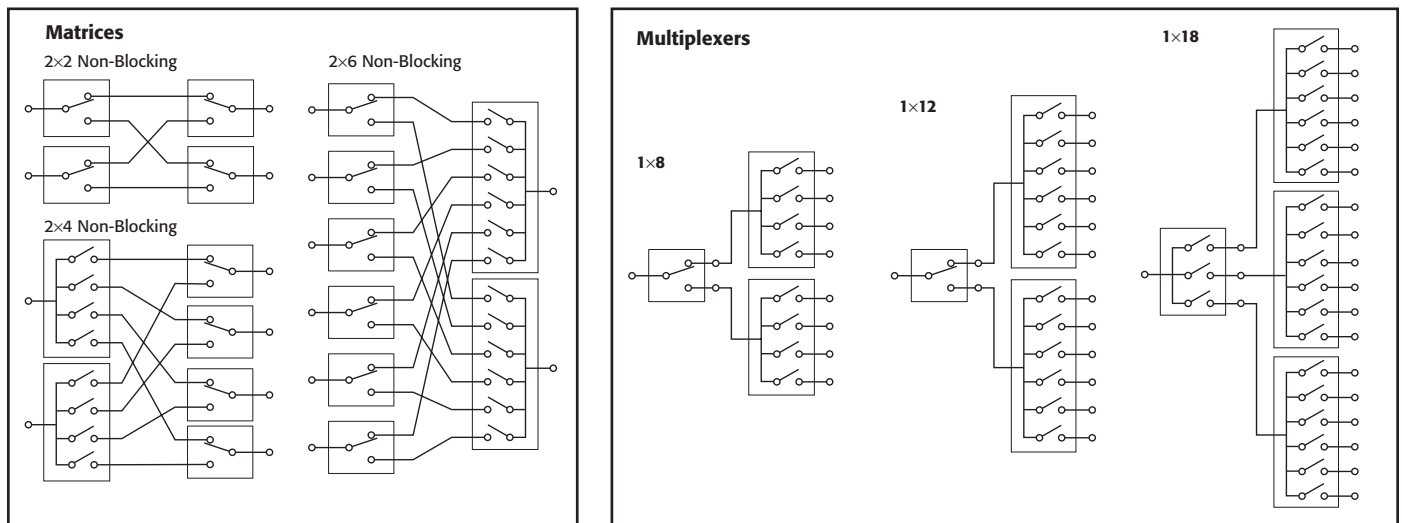

MAXIMUM CONFIGURATION: (8) – Unterminated SPDT relays. (4) – Unterminated multi-pole relays (SP4T, SP6T).

System 46

RF/Microwave Switch System 32-channel, Unterminated

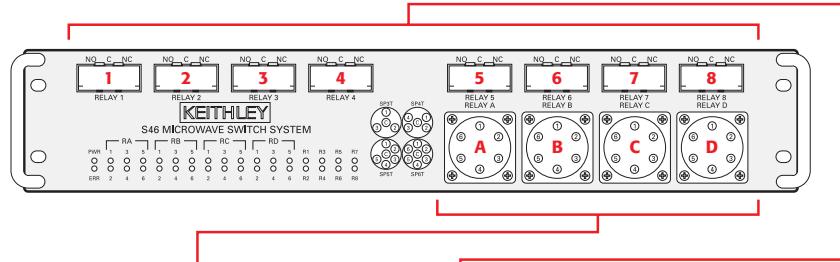

Ordering Information

Specifying Standard
S46 Model Numbers



Accessories Supplied

Power cord, instruction
manual, and rack mount kit

S46-

SP4T or SP6T Relay Locations SPDT Relay Locations Frequency Range

A B C D **1 2 3 4 5 6 7 8** **Blank A B C**

All four positions must be listed. **Only positions used must be listed.** Enter: Blank = DC–18GHz, Standard Performance

Enter: 0 = None Enter: 1–8 Position Number A = DC–18GHz, High Performance

4 = SP4T B = DC–26.5GHz

6 = SP6T C = DC–40GHz

Multipole relay locations A–D: Enter a “4” for an SP4T relay or a “6” for a SP6T relay in the required location. Enter a “0” in unused multi-pole locations. There must be digits in all four positions.

SPDT relay locations 1–8: Indicate the position number of all locations where an SPDT switch is required. Only locations used are required.

Example 1: Model Number S46-0604356

Includes: SP6T in position B, SP4T in position D, SPDTs in positions 3, 5, and 6. Frequency range “Blank,” standard performance DC–18GHz.

Example 2: Model Number S46-0440123B

Includes: SP4T in positions B and C, SPDTs in positions 1, 2, and 3. Frequency range “B,” high performance DC–26.5GHz.

Unterminated Relay Specifications

Option	None Std. Performance	High Performance		
		A	B	C
FREQUENCY RANGE	DC–18 GHz	DC–18 GHz	DC–26.5 GHz	DC–40 GHz
CONNECTOR TYPE	SPDT: SMA SP4T, SP6T: SMA	SMA	SMA SMA 2.9	SMA 2.9
IMPEDANCE	50Ω	50Ω	50Ω	50Ω
CONTACT LIFE	SPDT: 2 × 10 ⁶ SP4T, SP6T: 2 × 10 ⁶	1 × 10 ⁷	1 × 10 ⁷	1 × 10 ⁷
VSWR (max.)	DC–6 GHz: 1.25 6–12 GHz: 1.40 12–18 GHz: 1.50	DC–3 GHz: 1.20 3–8 GHz: 1.30 8–12.4 GHz: 1.40 12.4–18 GHz: 1.50	DC–6 GHz: 1.30 6–12.4 GHz: 1.40 12.4–18 GHz: 1.50 18–26.5 GHz: 1.70	DC–6 GHz: 1.30 6–12.4 GHz: 1.40 12.4–18 GHz: 1.50 18–26.5 GHz: 1.70 26.5–40 GHz: 2.20
INSERTION LOSS (max.) dB	DC–6 GHz: 0.2 6–12 GHz: 0.4 12–18 GHz: 0.5	DC–3 GHz: 0.2 3–8 GHz: 0.3 8–12.4 GHz: 0.4 12.4–18 GHz: 0.5	DC–6 GHz: 0.2 6–12.4 GHz: 0.4 12.4–18 GHz: 0.5 18–26.5 GHz: 0.7	DC–6 GHz: 0.2 6–12.4 GHz: 0.4 12.4–18 GHz: 0.5 18–26.5 GHz: 0.7 26.5–40 GHz: 1.1
ISOLATION (min.) dB	DC–6 GHz: 70 6–12 GHz: 60 12–18 GHz: 60	DC–3 GHz: 80 3–8 GHz: 70 8–12.4 GHz: 60 12.4–18 GHz: 60	DC–6 GHz: 70 6–12.4 GHz: 60 12.4–18 GHz: 60 18–26.5 GHz: 55	DC–6 GHz: 70 6–12.4 GHz: 60 12.4–18 GHz: 60 18–26.5 GHz: 55 26.5–40 GHz: 50
ACTUATION TIME (max.) ms	SPDT: 20 SP4T, SP6T: 15	10 15	10 15	10 15

GENERAL

CONTACT CLOSURE COUNTERS: 1 counter per channel, up to 10 million counts each, maintained in non-volatile memory.

NON-VOLATILE STORAGE: 32 separate locations; each location up to 68 bytes long, for user-definable channel and system parameters.

NUMBER OF RELAY CONTROL LINES: 32, each open collector driver capable of 300mA sink current (max.).

INTERFACE: GPIB (IEEE-488.2) and SCPI.

INDICATORS: Power, relay position status, and error LED.

POWER: 100–240VAC, 50/60Hz.

MAXIMUM COMMON MODE: 42V peak, any terminal to earth.

ENVIRONMENT: Operating: 0° to 40°C, up to 35°C < 80% RH. **Storage:** –25° to 65°C.

EMC: Conforms to European Union Directive 89/336/EEC.

SAFETY: Conforms with European Union Directive 73/23/EEC.

DIMENSIONS: 89mm high × 485mm wide × 370mm. deep (3.5” × 19” × 14.563”).

SHIPPING WEIGHT: 13kg (28 lbs).

1.888.KEITHLEY (U.S. only)

www.keithley.com



System 46T

RF/Microwave Switch System 32-channel, Terminated

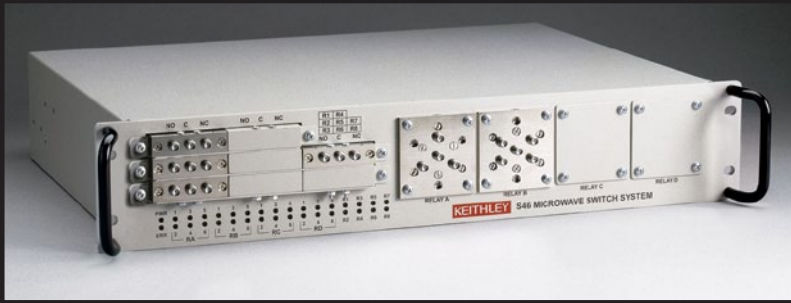

- Compact RF/microwave switching system only 2U high
- Built-in contact closure counter to monitor switch cycles
- Standard configuration allows up to 32 channels of switching
- Simple control with built-in GPIB/IEEE-488 interface bus
- Channel characterization data storage
- Terminated switching configurations
- Frequency ranges up to 26.5GHz

Terminated Switching Solutions

If your application requires a terminated configuration, the System 46T will meet your needs. This compact switching system leverages the same design technology of our standard unterminated System 46. This terminated version can accommodate up to eight terminated SPDT coaxial microwave relays and four terminated multi-pole coaxial microwave relays.

Maximum Flexibility

In addition to the terminated configurations, the System 46T also has provisions to accommodate up to four

transfer switches (DPDT) as well as frequency ranges up to 26.5GHz. Other options include adding unterminated multi-throw and SPDT switches. Please review the Ordering Information section for allowable configurations.

Simple Operation

The S46T switch system's 32 control channels can be operated via the IEEE-488 interface bus with a minimal set of instructions. This small instruction set ensures the system can be set up and running quickly. Front panel LEDs indicate the status of all relay contacts continuously to allow the user to monitor system operation easily.

Excellent Microwave Switching Performance

Keithley's experience and partnerships with leading manufacturers in the microwave relay industry allow Keithley to offer the lowest insertion loss, VSWR, and crosstalk performance specifications available. Low-loss, semi-flexible RF cables are available as accessories to maximize signal integrity.

Maximum System Up-Time and Enhanced System Performance

The S46T controller automatically counts relay contact closures to allow equipment maintenance personnel to assess when the relays are nearing the end of their mechanical life. In this way, preventive maintenance can be performed in a timely way during scheduled shutdowns, avoiding unplanned shutdowns and the resulting loss of production time.

In addition to counting contact closures, the S46T has a portion of its memory available to store S-parameters or calibration constants for each relay contact or each pathway. If a specific performance parameter is critical, such as Voltage Standing Wave Ratio (VSWR) or insertion loss, the parameter can be stored in memory for use in trend analysis between scheduled maintenance shutdowns. Stored parameters can also be used for compensation to enhance accuracy during RF measurements.

ACCESSORIES AVAILABLE

CABLES, ADAPTERS, TOOLS

7007-1	Shielded GPIB Cable, 1m (3.3 ft.)
7007-2	Shielded GPIB Cable, 2m (6.6 ft.)
7712-SMA-1	SMA Cable, male to male, 1m (3.3 ft.)
CA-404-B	SMA Cable, male to male, RG188 cable, 2m (6.5 ft.)
KPCI-488LPA	IEEE-488 Interface/Controller for the PCI Bus
KUSB-488B	IEEE-488 USB-to-GPIB Interface Adapter
S46-SMA-0.5	DC-18GHz, Low Loss, Semi-Flex SMA-SMA Cable Assembly, 0.152m (6 in.)
S46-SMA-1	DC-18GHz, Low Loss, Semi-Flex SMA-SMA Cable Assembly, 0.305m (12 in.)
S46-SMA-1.7	DC-18GHz, Low Loss, Semi-Flex SMA-SMA Cable Assembly, 0.518m (20.4 in.)
S46-SMA26-0.5	DC-26.5GHz, Low Loss, Semi-Flex SMA-SMA Cable Assembly, 0.152m (6 in.)
S46-SMA26-1	DC-26.5GHz, Low Loss, Semi-Flex SMA-SMA Cable Assembly, 0.305m (12 in.)
S46-SMA26-1.7	DC-26.5GHz, Low Loss, Semi-Flex SMA-SMA Cable Assembly, 0.518m (20.4 in.)
TL-24	SMA Cable Torque Wrench

SWITCH KITS

S46T-MSPDT-KIT	Quantity 2, 18GHz Unterminated SPDT Relays, Mounting Plate, and Control Cable Assembly (Note: Kit applicable only for relay A-D mounting locations)	S46T-SPDT-KIT-26	26.5GHz Unterminated SPDT Relay, Spacer Block, and Control Cable Assembly
S46T-SPDT-KIT	18GHz Unterminated SPDT Relay, Spacer Block, and Control Cable Assembly	S46T-SPDT-KIT-26T	26.5GHz Terminated SPDT Relay and Control Cable Assembly
S46T-SPDT-KIT-T	18 GHz Terminated SPDT Relay and Control Cable Assembly	S46T-MSPDT-KIT-26	Quantity 2, 26.5GHz Unterminated SPDT Relays, Mounting Plate, and Control Cable Assembly (Note: Kit applicable only for relay A-D mounting locations)
S46T-SP4T-KIT	18GHz Unterminated SP4T Relay, Mounting Plate, and Control Cable Assembly	S46T-SP4T-KIT-26	26.5GHz Unterminated SP4T Relay, Mounting Plate, and Control Cable Assembly
S46T-SP4T-KIT-T	18GHz Terminated SP4T Relay, Mounting Plate, and Control Cable Assembly	S46T-SP4T-KIT-26T	26.5GHz Terminated SP4T Relay and Control Cable Assembly
S46T-SP6T-KIT	18GHz Unterminated SP6T Relay, Mounting Plate, and Control Cable Assembly	S46T-SP6T-KIT-26	26.5GHz Unterminated SP6T Relay, Mounting Plate, and Control Cable Assembly
S46T-SP6T-KIT-T	18 GHz Terminated SP6T Relay, Mounting Plate, and Control Cable Assembly	S46T-SP6T-KIT-26T	26.5GHz Terminated SP6T Relay and Control Cable Assembly
S46T-XFR-KIT	18GHz Transfer Switch, Mounting Plate, and Control Cable Assembly	S46T-XFR-KIT-26	26.5GHz Transfer Switch, Mounting Plate, and Control Cable Assembly

1.888.KEITHLEY (U.S. only)

www.keithley.com

KEITHLEY

A GREATER MEASURE OF CONFIDENCE

Designed for test applications that require high quality RF/microwave signal routing

SWITCHING AND CONTROL

System 46T

RF/Microwave Switch System 32-channel, Terminated

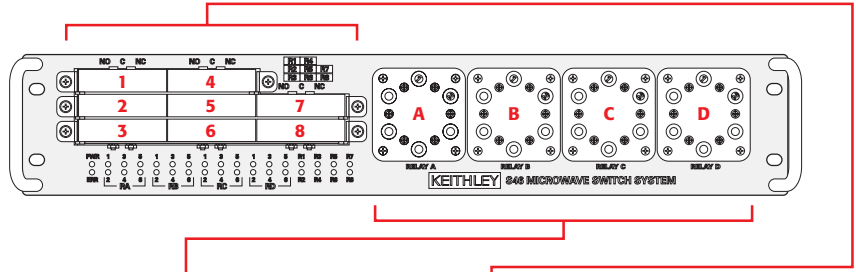

Ordering Information

Specifying Standard
S46T Model Numbers



Accessories Supplied

Power cord, instruction
manual, and rack mount kit

SP4T or SP6T Relay Locations

S46T-
A B C D

All four positions
must be listed.

Enter:

O = None

A = Terminated, SP4T

B = Terminated, SP6T

C = Unterminated, SPDT (2)

4 = Unterminated, SP4T

6 = Unterminated, SP6T

X = Transfer Switch, DPDT

SPDT Relay Locations

1 2 3 4 5 6 7 8

All eight positions
must be listed.

Enter:

O = None

T = Terminated, SPDT

U = Unterminated, SPDT

Frequency
Range

Must be specified.

Enter:

A = DC-18GHz

B = DC-26.5GHz

Example 1: Model Number S46T-0A0X00TT0000A

Includes: Terminated SP4T in position B, transfer switch in position D, terminated SPDTs in positions 3 and 4. DC-18GHz frequency range.

Example 2: Model Number S46T-ABC4UU00TTTTB

Includes: Terminated SP4T in position A, terminated SP6T in position B, two unterminated SPDTs in position C, and unterminated SP4T in position D. Unterminated SPDTs in positions 1 and 2, terminated SPDTs in positions 5, 6, 7, and 8. DC-26.5GHz frequency range.

APPLICATIONS

- Cellular and cordless phones
- Specialized mobile radios
- Base stations
- Specialized antenna systems
- RF components, including RFICs
- Wireless peripherals, including Bluetooth devices
- Broadband wireless transceivers
- High speed digital communications, including SONET speeds 3Gbps and 10Gbps

Terminated Relay Specifications

Frequency Range	DC-18 GHz	DC-26.5 GHz
CONNECTOR TYPE	SMA	SMA
IMPEDANCE	50Ω	50Ω
CONTACT LIFE: SPDT	2 × 10 ⁶	2 × 10 ⁶
CONTACT LIFE: SP4T, SP6T	2 × 10 ⁶	2 × 10 ⁶
VSWR (max.)	DC-3 GHz: 1.20 3-8 GHz: 1.30 8-12.4 GHz: 1.40 12.4-18 GHz: 1.50	DC-3 GHz: 1.20 3-8 GHz: 1.30 8-12.4 GHz: 1.40 12.4-18 GHz: 1.50 18-26.5 GHz: 1.80
INSERTION LOSS (max.) dB	DC-3 GHz: 0.2 3-8 GHz: 0.3 8-12.4 GHz: 0.4 12.4-18 GHz: 0.5	DC-3 GHz: 0.2 3-8 GHz: 0.3 8-12.4 GHz: 0.4 12.4-18 GHz: 0.5 18-26.5 GHz: 0.7
ISOLATION (min.) dB	DC-3 GHz: 80 3-8 GHz: 70 8-12.4 GHz: 60 12.4-18 GHz: 60	DC-3 GHz: 80 3-8 GHz: 70 8-12.4 GHz: 60 12.4-18 GHz: 60 18-26.5 GHz: 50
ACTUATION TIME (max.) ms	SPDT: 10 SP4T, SP6T: 15	SPDT: 10 SP4T, SP6T: 15

See page 212 for unterminated relay specifications.

Transfer Switch Specifications

Frequency Range	DC-18 GHz	DC-26.5 GHz
CONNECTOR TYPE	SMA	SMA 2.9
IMPEDANCE	50Ω	50Ω
CONTACT LIFE	2.5 × 10 ⁶	2.5 × 10 ⁶
VSWR (max.)	DC-3 GHz: 1.20 3-8 GHz: 1.30 8-12.4 GHz: 1.40 12.4-18 GHz: 1.50	DC-3 GHz: 1.20 3-8 GHz: 1.30 8-12.4 GHz: 1.40 12.4-18 GHz: 1.50 18-26.5 GHz: 1.70
INSERTION LOSS (max.) dB	DC-3 GHz: 0.2 3-8 GHz: 0.3 8-12.4 GHz: 0.4 12.4-18 GHz: 0.5	DC-3 GHz: 0.2 3-8 GHz: 0.3 8-12.4 GHz: 0.4 12.4-18 GHz: 0.5 18-26.5 GHz: 0.7
ISOLATION (min.) dB	DC-3 GHz: 80 3-8 GHz: 70 8-12.4 GHz: 60 12.4-18 GHz: 60	DC-3 GHz: 80 3-8 GHz: 70 8-12.4 GHz: 60 12.4-18 GHz: 60 18-26.5 GHz: 50
ACTUATION TIME (max.) ms	15	15

7116-MWS

RF/Microwave Switch System 1×16 Multiplexer, Unterminated



- **Integrated solution, including controller and RF/microwave switches**
- **Compact RF/microwave switching system only 3U high**
- **Configurable as one 1x16 or five independent 1x4 multiplexers**
- **18GHz bandwidth relays**
- **Real-time status display of all switches**
- **Local and remote control**

Ordering Information

7116-MWS 16-channel Microwave Switch System

Extended warranty, service, and calibration contracts are available.

Accessories Supplied

Instruction manual and power line cord

The Model 7116-MWS is a fully assembled 16-channel RF/Microwave Switch System designed to simplify controlling high frequency switching. It employs the IEEE-488-compatible Model 7001 Switch Mainframe as a switch controller as well as electromechanical coaxial relays with a bandwidth from DC to 18GHz. Applications include production and laboratory testing of a variety of communications devices and systems.

Simple Setup and Control

All input and output connections are easily accessible from the front panel, so system maintenance and reconfiguration is fast and easy. In addition, the non-volatile memory in the Model 7001 is pre-programmed in a 1×16 multiplexer switching pattern, allowing users to begin operating it immediately.

High Signal Integrity

All RF/microwave relay interconnections are implemented using low-loss, semi-rigid RF cabling to ensure high signal integrity. Signal paths are of equal length to ensure similar transmission line characteristics and performance in every channel. The relays used provide high isolation to minimize channel crosstalk. The Model 7116-MWS's combination of low insertion loss and high isolation ensures high quality measurement pathways for signal routing and measurement.

Expandable

The Model 7001 mainframe has a spare card slot available that allows control of up to 40 additional switch channels. More than 30 cards are available to expand the Model 7116-MWS's switching capabilities to include low frequency, general purpose, optical, or additional RF switching.

Industry-Leading IEEE-488 Controller

The Keithley Model 7001 Switch Mainframe included in the Model 7116-MWS has a distinctive front panel vacuum fluorescent display that provides continuous, real-time information on the status of all switches. Intuitive front panel controls allow the system to be manually operated, speeding and simplifying test verification and troubleshooting. Up to 100 complete switch patterns can be programmed in the Model 7001's non-volatile memory.

APPLICATIONS

- **Cellular and cordless phones**
- **Specialized mobile radios**
- **Base stations**
- **Specialized antenna systems**
- **RF components, including RFICs**
- **Wireless peripherals, including Bluetooth devices**
- **Broadband wireless transceivers**
- **High speed digital communications, including SONET speeds 3Gbps and 10Gbps**

1.888.KEITHLEY (U.S. only)

www.keithley.com

KEITHLEY

A GREATER MEASURE OF CONFIDENCE

7116-MWS

RF/Microwave Switch System 1×16 Multiplexer

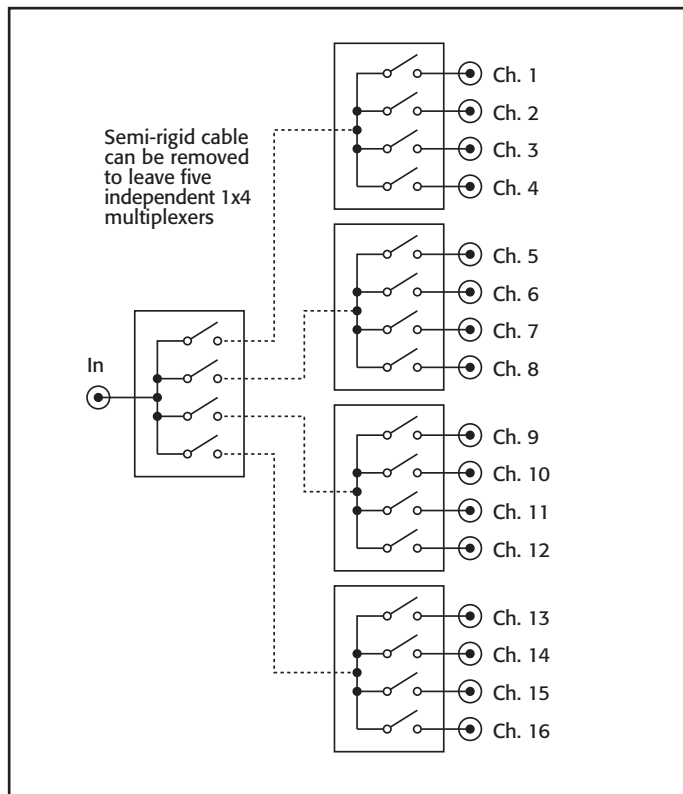

SYSTEM SPECIFICATIONS

Operating Frequency	DC–3 GHz	3–6 GHz	6–12 GHz	12–18 GHz
Insertion Loss dB, maximum	0.5 (0.2)	0.75 (0.3)	1 (0.4)	1.3 (0.5)
Isolation dB, minimum	80	70	60	60
RF Power W, maximum	30 (34)	20 (34)	15 (34)	10 (34)
VSWR	1.35 (1.2)	1.5 (1.3)	1.7 (1.4)	1.9 (1.5)

Values in parentheses are for individual SP4T switches.

SWITCH CONFIGURATION: 16 input coaxial multiplexer. Five independent unterminated SP4T switches when jumpers removed.

CONNECTOR: SMA.

ACTUATING CURRENT: 140mA per switch contact.

IMPEDANCE: 50Ω.

ACTUATION TIME: 15ms.

RF CONTACTS: Break-before-make, normally open.

OPERATING LIFE: Cold Switching: 1,000,000 operations.

CONFIGURATION:

Control: 7001 mainframe and 7020-MWS.

Power Supply: 29V DC, 1.6A switching power supply.

RF Interconnects: RG-402 (0.141 in. semi-rigid cable terminated with male SMA connectors).

Switch: Normally open, DC–18GHz unterminated SP4T switch.

System Enclosure: 5¼ in. full system rack kit.

EMC: Conforms to European Union Directive 89/336/EEC.

SAFETY: Conforms to European Union Directive 73/23/EEC (meets EN61010-1/IEC 1010).

POWER: 90–260V AC, 47–63Hz, 80VA maximum.

ENVIRONMENT:

Operating: 0°–50°C, up to 35°C at 80% R.H.

Storage: –25°C to +65°C.

DIMENSIONS, WEIGHT: 133mm high × 482mm wide × 457mm deep (5¼ in × 19 in × 18 in).
Net weight 8.1kg (18 lbs).

ACCESSORIES AVAILABLE

7007-1	Shielded GPIB Cable, 1m (3.3 ft)
7007-2	Shielded GPIB Cable, 2m (6.6 ft)
7116-COVER	Top Protective Cover
KPCI-488LPA	IEEE-488 Interface/Controller for the PCI Bus
KUSB-488B	IEEE-488 USB-to-GPIB Interface Adapter

1.888.KEITHLEY (U.S. only)

www.keithley.com

KEITHLEY

A GREATER MEASURE OF CONFIDENCE