

IVA-CPA

CABLE AND ANTENNA ANALYZER WITH CHANNEL POWER ANALYSIS MODE

The iVA-CPA is a new solution that adds Channel Power measurement capability to the existing base iVA analyzer. The iVA-CPA comes with all the features of the base iVA analyzer and includes Channel Power mode for additional functionality.

Channel Power mode enables the user to determine the total RF power between any two frequencies in a spectrum monitor trace. Measurement modes include CW signal and modulated signal.

FEATURES

- Measurement bandwidths of up to 75 MHz allowed
- Levels ranging from -100 to +15 dBm
- Both modulated and continuous wave signals supported
- Comes with all features of base iVA Cable and Antenna Analyzer

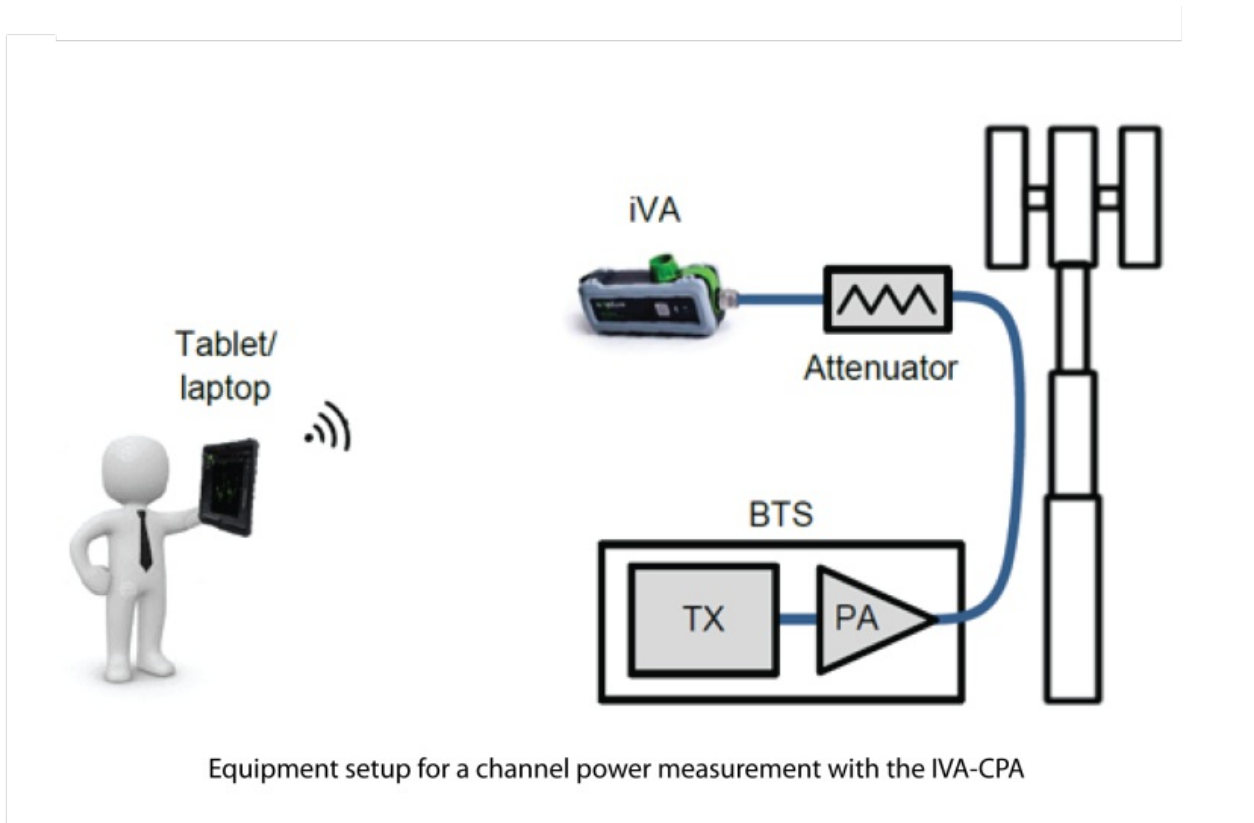

IVA-CPA TECHNICAL SPECIFICATIONS

IVA ANALYSIS MODE - CHANNEL POWER MODE	
Measurement modes	CW Signal Mode Modulated Signal Mode
Dyanamic range in CW mode	
Low power range	-100 to -35 dBm
High power range	-45 to +15dBm
Minimum detectable signal in modulated mode	
Low power range	10 log(B) -87 dBm
High power range	10 log(B) -32 dBm
Maximum detectable signal in modulated mode	
Low power range	Min(-0.5, 10 log(B) - 14) dBm
High power range	+15 dBm
Power measurement accuracy	± 1.5 dB typ ± 3 dB max
Measurement channel bandwidth	
CW mode	1 kHz to 20 MHz
Modulated mode	1 kHz to 2190 MHz
Max number of measurement channels	1
Sweep speed	2ms per frequency point
Maximum input power without damage	+23 dBm

- 1 Occupied bandwidth and Adjacent Channel Power Ratio features to be included in future release of application software.
 2 B is the occupied bandwidth of the measured signal in MHz.
 3 Accuracy specification assumes that the measured signal is the only signal present during a measurement. The iVA's accuracy may be degraded if other signals are present during a Channel Power measurement, especially if the aggregate RF power at the test port exceeds the iVA's compression point.
 4 Future releases of Unify will allow the user to define up to 10 simultaneous measurement channels across the frequency range of interest.

BASE IVA TECHNICAL SPECIFICATIONS

KEY SPECIFICATION - IVA (SEE IVA DATASHEET FOR FULL SPECIFICATIONS)	
iVA analysis modes	Return Loss, VSWR, Cable Loss, Distance to Fault (DTF), Isolation, Spectrum Monitor
Minimum frequency increment	1kHz all modes
Number of measurement points	1 to 2191

ELECTRICAL	
DC power consumption	
Return loss mode	4.7W
Transmission mode	4.7W
Spectrum monitor mode	3.7W
Standby (Idle)	0.6W
Battery	Lithium-Ion 3.6V, 2350 mAh, 8.5Wh
Battery charging method	USB-compatible power source connected to USB port of iVA
Battery operating time	8 Hours at typical usage factor

INSTRUMENT CONTROL	
User interface	USB or Bluetooth supported user device with iVA application software installed
Supported devices	iPA Portable PIM Analyzer Tablet computer (iOS & Android) Smartphone (iOS & Android) PC, Windows 7,8 & 10 running .NET version 4 or later
Communications interface to iVA	Bluetooth and USB 2.0
Bluetooth antenna	Integrated into housing
Maximum input power on RF port	+23dBm maximum, DC voltage ±30V

TECHNICAL SPECIFICATIONS

MECHANICAL	
Dimensions H x D x W	52 x 69.5 x 216mm 2.06 x 2.73 x 8.51in
Weight	0.68kg 1.5 lbs
Connector 1	RF test port iVA-0627A: Type N male, 50 ohms iVA-0627B: 4.3-10 male, 50 ohms
Connector 2	USB 2.0 Mini-B (for charging and connection to iPA or PC)
Mechanical Shock & Vibration	MIL-PRF-28800F Class 2, ETS 300 019-2-1, -2, -7
ENVIRONMENTAL	
Temperature range	-10°C to +55°C +14°F to +131°F (operational)
Ingress protection	IP54
Altitude	4600m 15,000ft maximum
Compliance	EMC- EN 61326-1:2013, EN 61326-2-1:2013, EN 55022:2010 "Class A" EN 61000-4-2, 4-3, 4-4, 4-5, 4-6, 4-11 Safety- EN 61010-1:2012, EN 61010-030:2012
Operational humidity	5% to 95% RH non-condensing
Storage temperature range	-20°C to +60°C -4°F to +140°F

ORDERING INFORMATION

1. CHOOSE BASE IVA WITH DESIRED ACCESSORIES

PART NUMBER	DESCRIPTION
iVA-0627A-NC	iVA Cable & Antenna Analyzer System, Type N male connector with Neoprene Soft Case
iVA-0627A-HC	iVA Cable and Antenna Analyzer System, Type N male connector with Hard Case
iVA-0627A-BK	iVA Cable & Antenna Analyzer System, Type N male connector with Basic Accessory Kit
iVA-0627A-SK-02	iVA Cable & Antenna Analyzer System, Type N male connector with Standard Accessory Kit
iVA-0627A-PK-02	iVA Cable & Antenna Analyzer System, Type N male connector with Premium Accessory Kit

2. ADD IVA CHANNEL POWER MODE

PART NUMBER	DESCRIPTION
iVA-SW-CPA	Base iVA + Channel Power Mode

Contact Kaelus at 1.303.768.8080 or +1.800.498.1352 to obtain additional information, request a quote or receive unit pricing on the Kaelus iVA - CPA analyzers.

MECHANICAL INTERFACE

