

TMA2043F1V1-1

TWIN TMA AWS, LOWPASS

Designed to be used at co-located 700MHz and AWS sites, the Kaelus TMA2043 provides internal diplexing of the two bands. External diplexers and feeders are no longer required, resulting in decreased hardware costs, environmental impact and tower licensing fees.

FEATURES

- LTE ready
- AISG 2.0 compatible, fully software upgradable
- Provides gain in the AWS path and bypass to 700MHz frequencies
- Excellent noise figure performance
- Full lightning protection and fail safe bypass mode

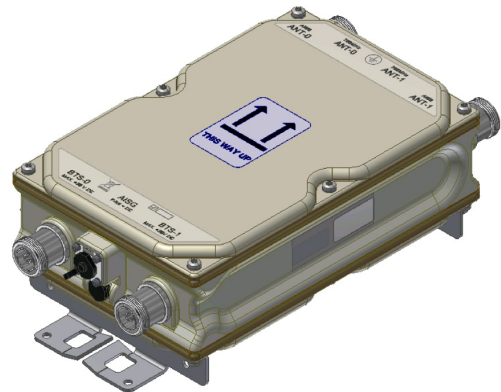

TECHNICAL SPECIFICATIONS

DOWNLINK AWS (TX) PATH	
Passband	2110 - 2170MHz
Insertion loss	0.25dB typical
Return loss	18dB minimum
Maximum input power	500W (average) / 5kW (PEP)
UPLINK AWS (RX) PATH	
Passband	1710 - 1770MHz
Nominal gain	12dB minimum
Noise figure	1.1dB typical
Return loss	18dB minimum operating, 15dB minimum in bypass mode
Bypass loss	2dB typical
Output IP3	+26dBm typical
Rejection in TX band	80dB minimum
Rejection @ 1700MHz	25dB minimum
Rejection @ 1800MHz	25dB minimum
700 MHZ BYPASS	
Passband	698 - 746MHz
Insertion loss	0.25dB typical
Return loss	18dB minimum
Maximum input power	500W (average) / 5kW (PEP)
ELECTRICAL	
Intermodulation products	-155dBc maximum at antenna ports with 2 x 20W carriers
GENERAL SPECIFICATIONS (MEASURED IN 180KHZ BANDWIDTH)	
Phase linearity, 700 & AWS	0.02° typical
Group delay variation, 700 & AWS	0.8ns typical
Amplitude variation, 700 & AWS	0.02dB typical
POWER SUPPLY AND ALARM (CURRENT WINDOW ALARM MODE, DEFAULT)	
CWA is the default TMA operating mode and can be configured to specific customer requirements. The TMA is configured so that each BTS port is individually powered and monitored. Each BTS port sinks additional current to indicate an alarm state in its uplink path. Normal operating and alarm current values are configured independently and are alterable via a field-loadable personality file, contact Kaelus for more information.	
DC supply voltage	7.5V to 30V DC, case is DC ground
DC supply	Through BTS connector
DC supply current, normal mode	100 ± 20mA per port
DC supply current, alarm mode	200 ± 30mA per port

POWER CONSUMPTION	
Normal operation	0.85W @ 7.5V, 3W @ 30V typical
Alarm mode	3W @ 15V per port typical

AISG MODE OF OPERATION (AUTO SELECTED ON VALID AISG 2.0 FRAMES)	
AISG signals can be applied to either BTS0 or BTS1 port. The TMA unit switches to AISG mode when valid frames are detected on one of the BTS ports. The TMA unit is DC powered (common feed for both channels) from the port supplying the AISG frames.	
DC supply voltage	7.5V to 30V DC, case is DC ground
AISG version	2.0 (1.1 optional)
Supply current, AISG mode	200mA @ 7.5V, 65mA @ 30V typical
Voltage drop, BTS to AISG port	1.5V maximum at 2A
Power consumption, AISG mode	1.5W @ 7.5V, 2W @ 30V typical
AISG connector, current rating	IEC60130-9, 8-pin female / < 4A peak, 2A continuous, pin 6

ENVIRONMENTAL	
For further details of environmental compliance, please contact Kaelus.	
Temperature range	-40° to +65°C -40° to +149°F
Ingress protection	IP67
Lightning protection	IEC61312-1, RF: ±5kA maximum (8/20us), AISG: ±2kA maximum (8/20us)
MTBF	>700,000 (hours)
Compliance	FCC Part 15, Ingress ETSI EN 300 019 class 4.1, RoHS

MECHANICAL	
Dimensions H x D x W	284 x 181.5 x 89mm 11.18 x 7.14 x 3.5in (excluding brackets and connectors)
Weight	9kg 20lbs
Finish	Painted, light grey (RAL7035)
Connectors	DIN 7-16 (F) x 6 long neck
Mounting	Pole/wall bracket supplied with two metal clamps 45-178mm diameter poles
Attenuation in AWS band	80dB minimum

ORDERING INFORMATION

PART NUMBER	DESCRIPTION
TMA2043F1V1-1	Twin TMA, 700MHz bypass, with pole mounting bracket

ELECTRICAL BLOCK DIAGRAM

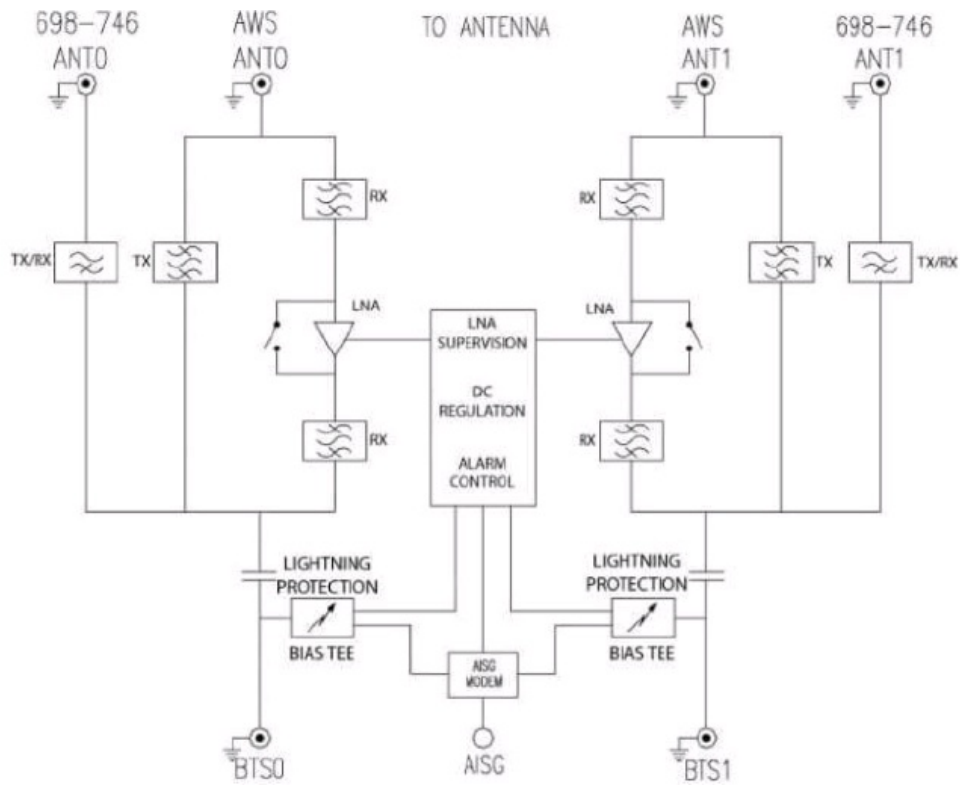

MECHANICAL BLOCK DIAGRAM

