

TMA2038F10V1-1

TWIN TMA 900

A 900MHz TMA, the TMA2038 has been designed to operate in any 900MHz cellular network and provides excellent noise figure performance with flexible AISG options.

FEATURES

- Dual duplexed TMA providing Improved base station sensitivity through excellent noise performance and high linearity
- Hardware and software configuration using AISG “personality” upload
- High reliability with full lightning protection and a fail-safe bypass mode
- AISG and current dump compatible
- Bandwidth 25MHz tunable anywhere in 900MHz band



TECHNICAL SPECIFICATIONS

DOWNLINK (TX) PATH	
Passband	Any 25MHz within 925-960MHz
Bandwidth	25MHz
Return loss	18dB minimum
Insertion loss	0.35dB typical mid band
EVM	3%
Group delay variation	5ns maximum (200kHz) 20ns maximum (4MHz)
Maximum input power with no damage	200W (average) / 1.6kW (PEP)
UPLINK (RX) PATH	
Passband	Any 25MHz within 880-915MHz
Bandwidth	25MHz
Nominal gain	Variable 8 to 16dB (selected via AISG)
Gain variation over frequency, temperature	±1dB maximum
Noise figure	1.0dB typical (12dB gain) 1.6dB maximum (12dB gain) at band edge
Return loss	18dB minimum operating, 12dB minimum in bypass mode
Insertion loss	2.0dB typical, 3dB maximum in bypass mode
Group delay variation	10ns maximum (200kHz) 40ns maximum (4MHz)
Maximum input power with no damage	+12dBm maximum
Input intercept point (3rd order)	+8dBm minimum
ELECTRICAL	
Impedance	50ohms
Intermodulation products	<-153dBc at antenna ports, with 2 x 43dBm TX carriers
REJECTION	
902.5 ANT to BTS 50 - 800MHz	46dB minimum
902.5 ANT to BTS 1050 - 2200MHz	46dB minimum
902.5 ANT to BTS 2200 - 2750MHz	26dB minimum

POWER SUPPLY AND ALARM (CURRENT WINDOW ALARM MODE, DEFAULT)	
Current window alarm mode (CWA) is the default TMA operating mode and can be configured to specific customer requirements. The generic personality is configured so that both channels are independently powered and monitored via the respective BTS port. The BTS port sinks additional current to indicate an alarm state in its uplink path. Normal operating and alarm current values are configured independently and are alterable via a field-loadable personality file.	
DC supply voltage	8.5V to 30V DC, case is DC ground
DC supply voltage via BTS-RF cable	Each BTS port powered individually (programmable)
DC supply current, normal mode	100 ± 20mA per port (programmable)
DC supply current, alarm mode	150 - 300mA per port (programmable)

AISG MODE OF OPERATION (AUTO SELECTED ON VALID AISG 2.0 FRAMES)	
AISG signals can be applied to either BTS1 or BTS2 port. The TMA unit switches to AISG mode when valid frames are detected on one of the BTS ports. Both LNA's take DC power from the port with AISG frames or, if DC is present on both ports, both channels supply equal power to the TMA.	
AISG version	2.0 (1.1 optional)
Supply current, AISG mode	55mA at 30V, 135mA at 12V
Power consumption, AISG mode	1.5W @ 7.5V, 1.8W @ 30V typical
AISG connector, current rating	IEC60130-9, < 4A peak, 2A continuous, pin 6
Field firmware upgradable	Yes

ENVIRONMENTAL	
For further details of environmental compliance, please contact Kaelus.	
Temperature range	-40° to +65°C -40° to +149°F
Ingress protection	IP67
Lightning protection	IEC61312-1, RF: ±2kA maximum (10/350us) AISG: ±0.5kA maximum (10/350us)
MTBF	>500,000 (hours)
Compliance	EMC:EN301 489, ETSI EN 300 019 class 4.1, RoHS

MECHANICAL	
Dimensions H x D x W	217 x 239 x 81mm 8.54 x 9.41 x 3.19in
Weight	7.5kg 16.53lbs
Finish	Painted, light grey (RAL7035)
Connectors	DIN 7-16 (F) x 4 long shank, AISG (F) x 1
Mounting	Pole/wall bracket supplied with two metal clamps 45-178mm diameter poles

ORDERING INFORMATION

PART NUMBER	DESCRIPTION
x Denotes different internal firmware for different CWA and BTS configurations	
TMA2038F1xV1-1	Twin TMA, 900MHz, uplink passband 890 to 915MHz, downlink passband 935 to 960MHz
TMA2038F2xV1-1	Twin TMA, 900MHz, uplink passband 880 to 905MHz, downlink passband 925 to 950MHz

ELECTRICAL BLOCK DIAGRAM

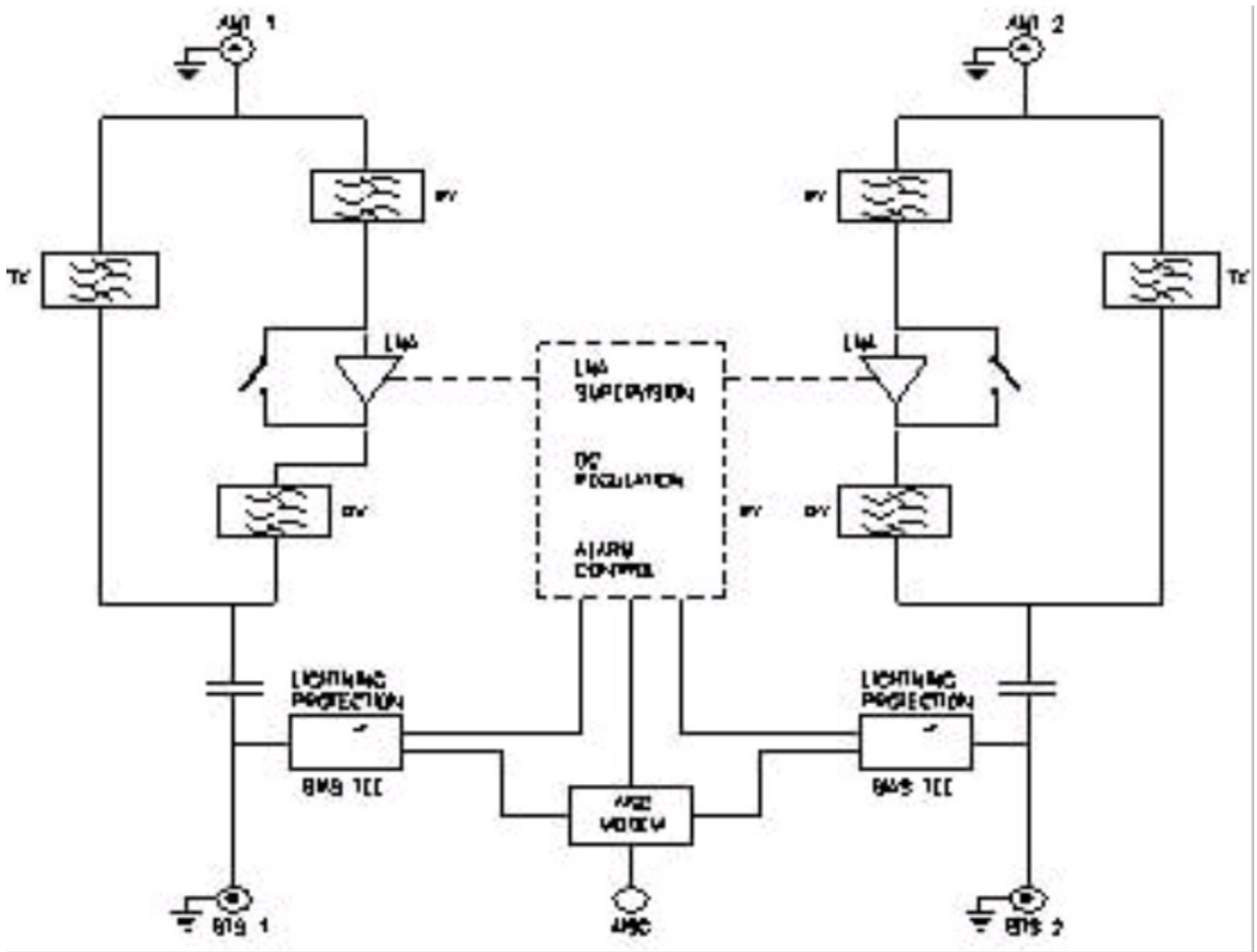

MECHANICAL BLOCK DIAGRAM

